

# HS50P / MS50

100,000 LB First Layer Line Pull

# BRADEN®

## DIMENSIONAL INFORMATION

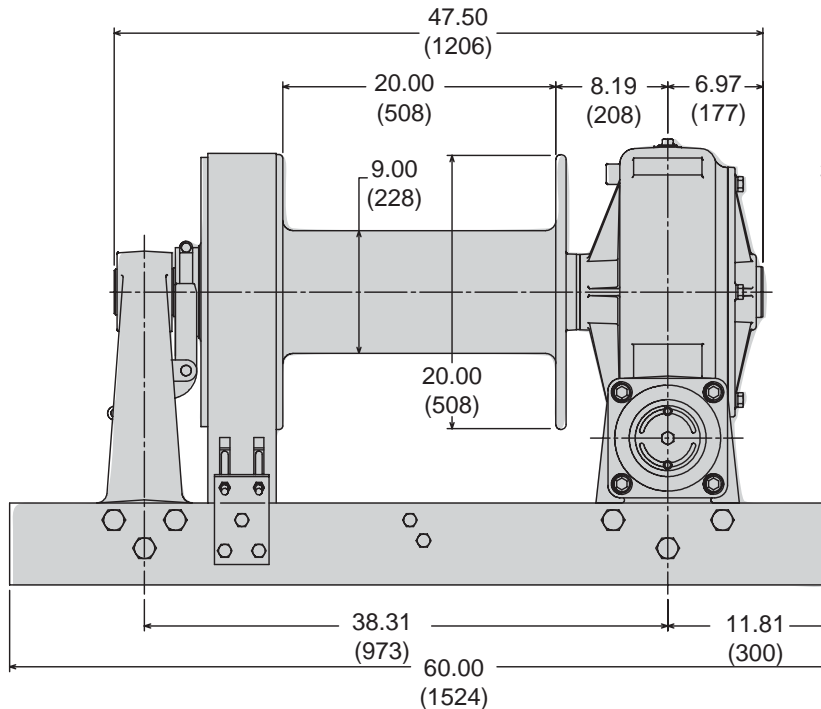

RIGHT HAND ASSEMBLY SHOWN.

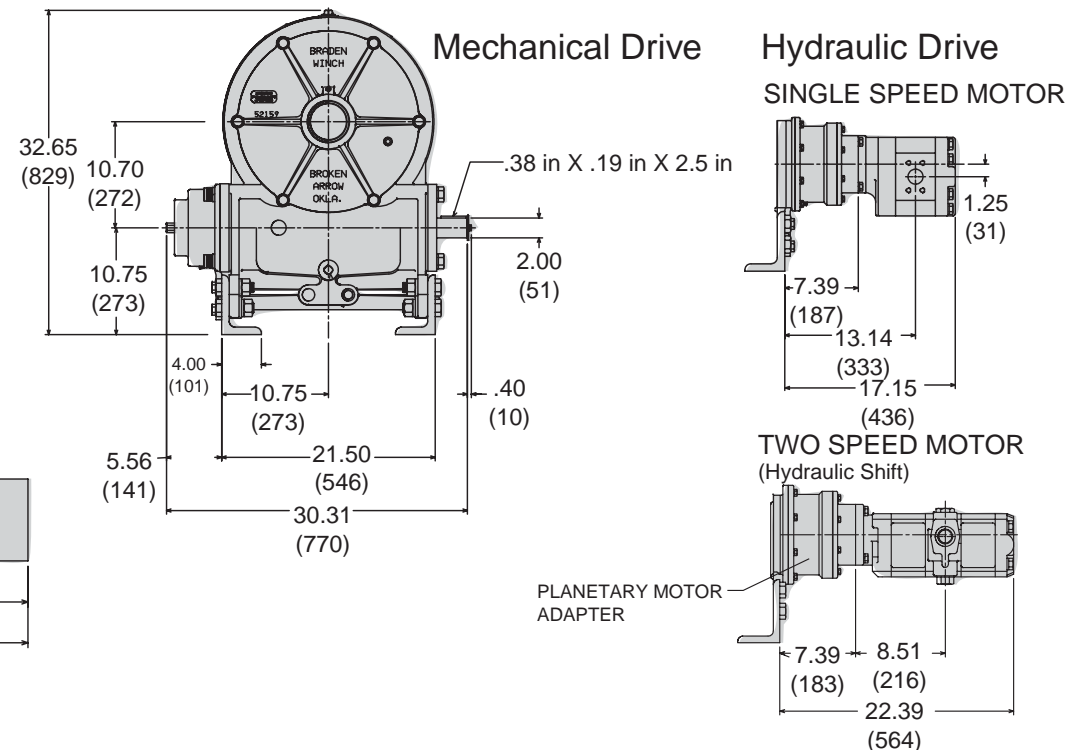

- Band brake around cable drum helps prevent “birdnesting” of cable when drum clutch is disengaged.
- Replaceable clutch jaws are bolted to cable drum.
- Oil-cooled, fully adjustable automatic worm brake.
- Tapered roller bearings provide extra capacity in carrying worm thrust and radial loads.
- Freespool clutch with negative draft jaws for positive engagement under load.

**PACCAR WINCH DIVISION**

P.O. Box 547 Broken Arrow, Oklahoma 74013

PHONE: (918) 251-8511 FAX: (918) 259-1575

[www.paccarwinch.com](http://www.paccarwinch.com)

**COMMITMENT**

Every process in the design, manufacture and support of BRADEN products is focused on one goal: Providing the highest quality winch, hoist and drive systems in the world.

PACCAR Winch Division is committed to providing the best in product design, durability and reliability. BRADEN products are supported with comprehensive publications, factory service representatives and a world wide distribution network.

Since 1905 PACCAR Inc has provided high quality products and services to numerous markets and countries. Let us put our experience and expertise to work for you.

[www.paccarwinch.com](http://www.paccarwinch.com)

**PERFORMANCE FORMULAS**

**LINE PULL AT LOWER PRESSURE**

$$\frac{\text{YOUR SYSTEM PRESSURE}}{\text{MAXIMUM PRESSURE (FROM CHART)}} \times \text{LINE PULL FROM CHART} = \text{LINE PULL ESTIMATE}$$

EXAMPLE:

$$\frac{1000 \text{ PSI}}{2300 \text{ PSI}} \times 35,000 \text{ LBS} = 15,217 \text{ LBS}$$

**NOTES**

Specifications are subject to change without notification and without incurring obligation.

Pressure and flow shown are the maximum allowable for the particular combination of winch, ratio, motor and drum.

Specifications in this publication are theoretical and may vary depending on hydraulic system, environment, etc.

Line pulls are maximum ratings for the winch only.

Wire rope ratings may be lower than the the winch rating. Consult the wire rope manufacturer for ratings.

**PERFORMANCE INFORMATION**

**Single Speed Performance**

12.03 cu in. (197 cc)  
3,000 Δ psi (207 Δ bar) @ 80 gpm (300 lpm)

1 1/8 in. WIRE ROPE						
LAYER	LINE PULL		LINE SPEED		ROPE CAPACITY	
	(lbs)	(kg)	(fpm)	(mpm)	(ft)	(m)
1	100,000	45,450	12	3.7	42	12.8
2	81,800	37,178	15	4.6	94	28.7
3	69,200	31,451	17	5.2	160	48.8
4	60,000	27,270	20	6.1	230	70.2

**⚠ WARNING ⚠**

A minimum of 5 wraps of wire rope must be left on the drum to prevent the load from being supported by the wire rope anchor alone. Since the wire rope anchor is not designed to hold the rated load, failure to leave 5 wraps of wire rope on the drum could cause the load to drop, which could result in property damage, personal injury or death.

**2-Speed Performance**

12.75/6.4 cu in. (209/105 cc)  
2000 Δ psi (138 Δ bar) @ 85 gpm (320 lpm)

Layer	Low Speed				High Speed			
	LINE PULL		LINE SPEED		LINE PULL		LINE SPEED	
	(lbs)	(kg)	(fpm)	(mpm)	(lbs)	(kg)	(fpm)	(mpm)
1	100,000	45,000	10	3.0	38,600	17,400	23	6.9
2	81,800	36,800	12	3.6	31,500	14,200	28	8.4
3	69,200	31,100	14	4.2	26,500	11,900	34	10.2
4	60,000	27,000	16	4.8	23,100	10,400	39	11.7

**WIRE ROPE CAPACITY**

ROPE SIZE	LAYER							
	1		2		3		4	
in.	ft	(m)	ft	(m)	ft	(m)	ft	(m)
1 1/8	42	12.8	94	28.7	160	48.8	230	70.1
1 1/4	39	11.9	87	26.5	140	42.7	210	64.0

WIRE ROPE CAPACITY SHOWN IS 90% OF THEORITICAL

**⚠ WARNING ⚠**

The products described herein are neither designed nor intended for use or application to equipment used in lifting or moving of persons.

**ENGINEERING DATA**

Worm Gear Ratio.....40:1  
Planetary Drive Ratio.....7.75:1  
Drum Shaft Diameter.....3 3/4 in. (95.25 mm)  
Oil Capacity.....34 pints  
Input Shaft Diameter.....2 in. (50.80 mm)  
Weight - 18" Drum (Winch Only)....1634 lbs. (741 kg)

**MECHANICAL REQUIREMENTS:**

Static Input Torque		Dynamic Input Torque		Max Input*
lb-in	N-m	lb-in	N-m	RPM
35,200	3,978	27,000	3,051	180

\*AT RATED LOAD