

BRADEN Gearmatic

BG6A & BG6B HYDRAULIC PLANETARY HOIST

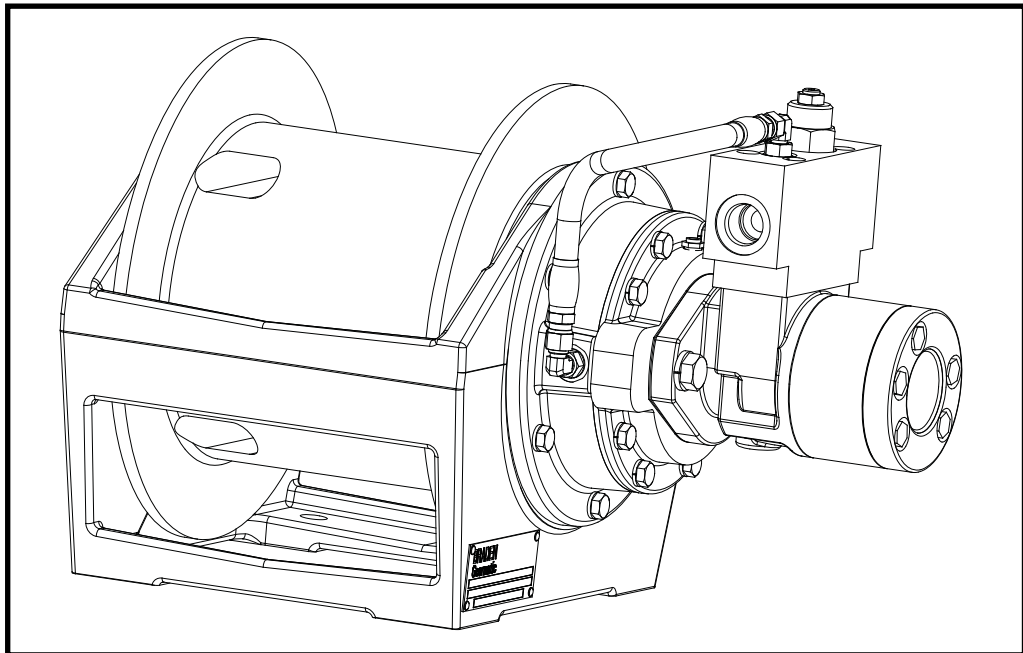





INSTALLATION, MAINTENANCE AND SERVICE MANUAL

TABLE OF CONTENTS

	PAGE
FOREWORD	2
PARTS AND SERVICE	2
GENERAL SAFETY RECOMMENDATIONS	3
DIMENSIONAL DATA	4
THEORY OF OPERATION	6-7
HYDRAULIC CIRCUIT	6
HOIST AND WIRE ROPE INSTALLATION	8
PREVENTATIVE MAINTENANCE	9
RECOMMENDED GEAR OIL	10
TROUBLE SHOOTING	11-13
HOIST EXPLODED VIEW DRAWING	14-15
PARTS KEY	14-15
HOIST SERVICE	16
HOIST DISASSEMBLY	16
BRAKE CYLINDER SERVICE	18-21
BRAKE CLUTCH SERVICE	22-23
PLANET CARRIER SERVICE	24-25
HOIST ASSEMBLY	26-29
REVERSING DIRECTION OF DRUM ROTATION	30
FASTENER TORQUE CHART	32
METRIC CONVERSION TABLE	33

.Safety informational callout's used in this manual include:

 WARNING 
WARNING - This emblem is used to warn against hazards and unsafe practices which could result in severe personal injury or death if proper procedures are not followed.

 CAUTION 
CAUTION - This emblem is used to warn against potential or unsafe practices which could result in personal injury or product or property damage if proper procedures are not followed.

FOREWORD

Read and understand this entire publication before operating or servicing your BRADEN hoist. Retain this manual for future reference.

The minimum service intervals specified are for operating hours of the prime mover.

The following service instructions have been prepared to provide assembly, disassembly and maintenance information for the Model BG6 series hoist. It is suggested that before doing any work on these units, all assembly and disassembly instructions should be read and understood.

Some illustrations in this manual may show details or attachments which may be different from your hoist. Also, some components may be removed for illustrative purposes.

Continuing product improvement may cause changes in your hoist which may not be included in this manual. When a question arises regarding your hoist or this manual, contact your nearest BRADEN dealer or the factory Service Department at 918-251-8511, Monday - Friday, 8:00 a.m. to 4:30 p.m. CST, or by Fax at 918-259-1575. Provide the complete hoist model number and serial number when making inquiries. The model and serial numbers are stamped into the data plate attached to the base, to the left of the hydraulic motor.

PARTS AND SERVICE

BRADEN provides parts and service through a network of authorized dealers. Parts and service are not available directly from the factory. For the name of your nearest dealer, consult your local phone directory or call us at the phone number shown above.

Serial Number and Model Number are located to the left of the hydraulic motor, stamped into the data plate. Always refer to the Serial Number and Model Number when requesting information or service parts.

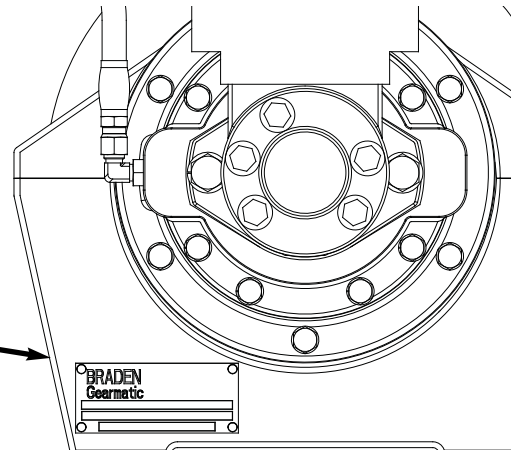

EXPLANATION OF MODEL NUMBER

BG6



HOIST
MODEL

B



DESIGN
MODEL

29



GEAR
RATIO

029



MOTOR
SIZE

01



DRUM
SIZE

-1



API

H



HIGH LINE
PULL OPTION

- BG6** DESIGNATES BRADEN GEARMATIC HOIST MODEL
- B** DESIGNATES THE MODEL SERIES RELATING TO DESIGN CHANGES
- 29** DESIGNATES TOTAL GEAR REDUCTION
- 029** DESIGNATES HYDRAULIC MOTOR DISPLACEMENT IN CU IN/REV
DECIMAL POINT ELIMINATED (029 = 2.9 cu in./rev [47.5 cu cm])
- 01** DESIGNATES THE DRUM
- 1** PERMITS TESTING AND INSPECTION PER API 2C RECOMMENDATIONS
- H** DESIGNATES HIGH LINE PULL OPTION

GENERAL SAFETY RECOMMENDATIONS

Safety for operators and ground personnel is of prime concern. Always take the necessary precautions to ensure safety to others as well as yourself. To ensure safety, the prime mover and hoist must be operated with care and concern by the operator for the equipment, and a thorough knowledge of the machine's performance capabilities. The following recommendations are offered as a general safety guide. Local rules and regulations will



also apply.

1. Read all warning tag information and become familiar with all controls before operating hoist.
2. Never attempt to clean, oil or perform any maintenance on a machine with the engine running, unless instructed to do so in the service manual.
3. Never operate hoist controls unless you are properly seated at the operators station on the prime mover and you are sure personnel are clear of the work area.
4. Assure that personnel who are responsible for hand signals are clearly visible and that the signals to be used are thoroughly understood by everyone.
5. Ground personnel should stay in view of the prime mover operator and clear of hoist drum. Do not allow ground personnel near hoist line under tension. A safe distance of at least 1½ times the working length of the cable should be maintained.
6. On machines having hydraulically, mechanically and/or cable controlled equipment, be certain the equipment is either lowered to the ground or blocked securely before servicing, adjusting and/or repairing the hoist. Always apply the prime mover parking brakes and lower equipment before dismounting the prime mover.
7. Inspect rigging, hoist and hydraulic hoses at the beginning of each work shift. Defects must be corrected before operating hoist.
8. Keep equipment in good operating condition. Perform scheduled servicing and adjustments listed in the "Preventive Maintenance" section of this manual.
9. An equipment warm-up procedure is recommended for all start-ups and is essential at ambient temperatures below +40°F (4.4°C). Refer to "Warm-up Procedure" listed in the "Preventive Maintenance" section of this manual.
10. Be sure of equipment stability before operating hoist.
11. The winches described herein are neither designed nor intended for use or application to equipment used in the lifting or moving of persons unless specially equipped from the factory. Refer to preventative maintenance section for more information.
12. Do not exceed the maximum pressure (PSI/ kPa) or flow (GPM/ LPH) stated in the hoist specifications.
13. Operate hoist line speeds to match job conditions.
14. Never handle the cable when hook end is free and wear protective gloves when handling wire rope.
15. When winding hoist cable on the hoist drum, never attempt to maintain tension by allowing hoist cable to slip through hands. Always use "hand-over-hand" technique.
16. Follow wire rope manufacturer's guidelines and applicable standards (such as ASME and API) for rigging and inspecting wire rope.
17. Do not weld on any part of the hoist.
18. Use recommended hydraulic oil and gear lubricant.
19. Keep hydraulic system clean and free from contamination at all times.
20. Use correct size cable anchor for cable and pocket in hoist drum.
21. The BRADEN wire rope anchors are capable of supporting the rated load when installed properly. For additional safety, ALWAYS maintain a minimum of five (5) wraps of wire rope on the drum.

DIMENSIONAL DATA - 01 DRUM

013 MOTOR

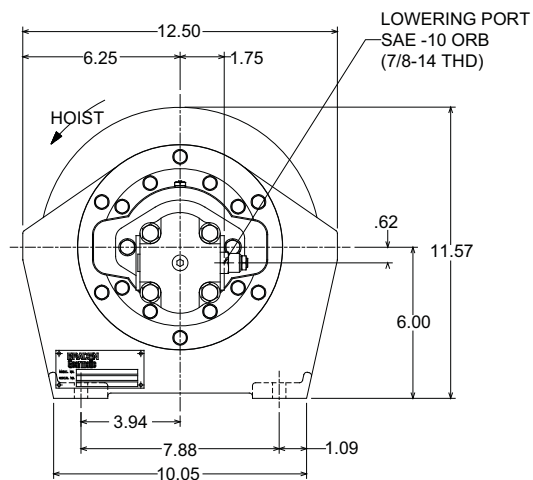
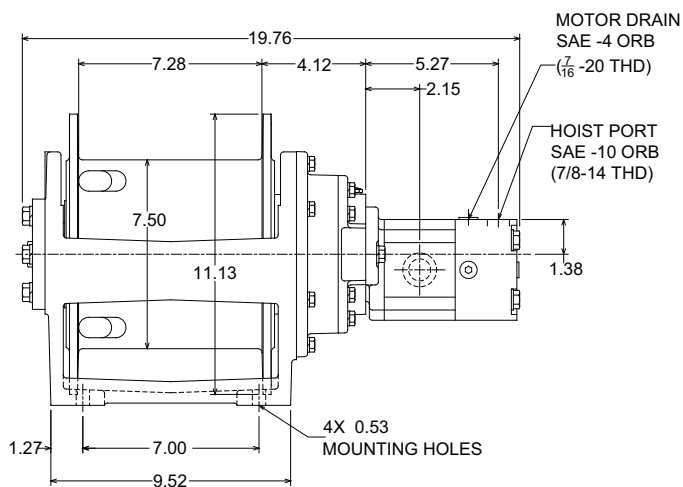

NOTE: Other motor options available as special order

MOTORS 020, 029, & 039

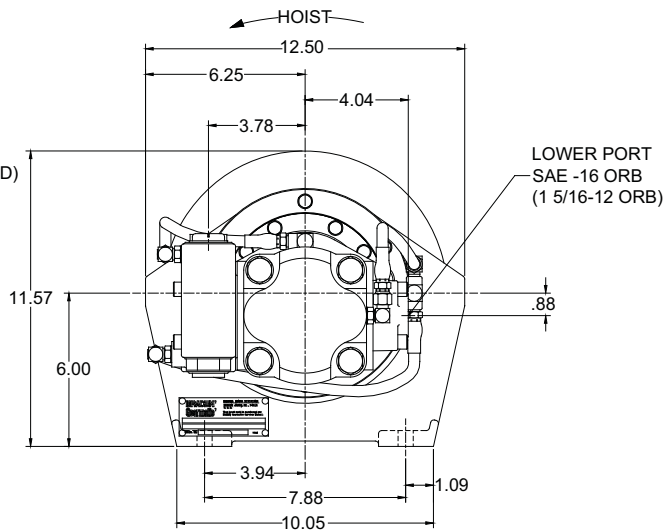
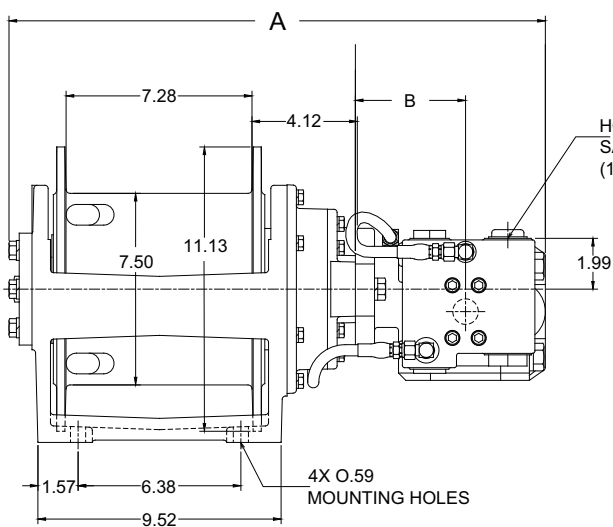

MOTOR	A	B
020	20.06	3.81
029	20.56	4.06
039	21.01	4.32

DIMENSIONAL DATA - 02 DRUM

013 MOTOR

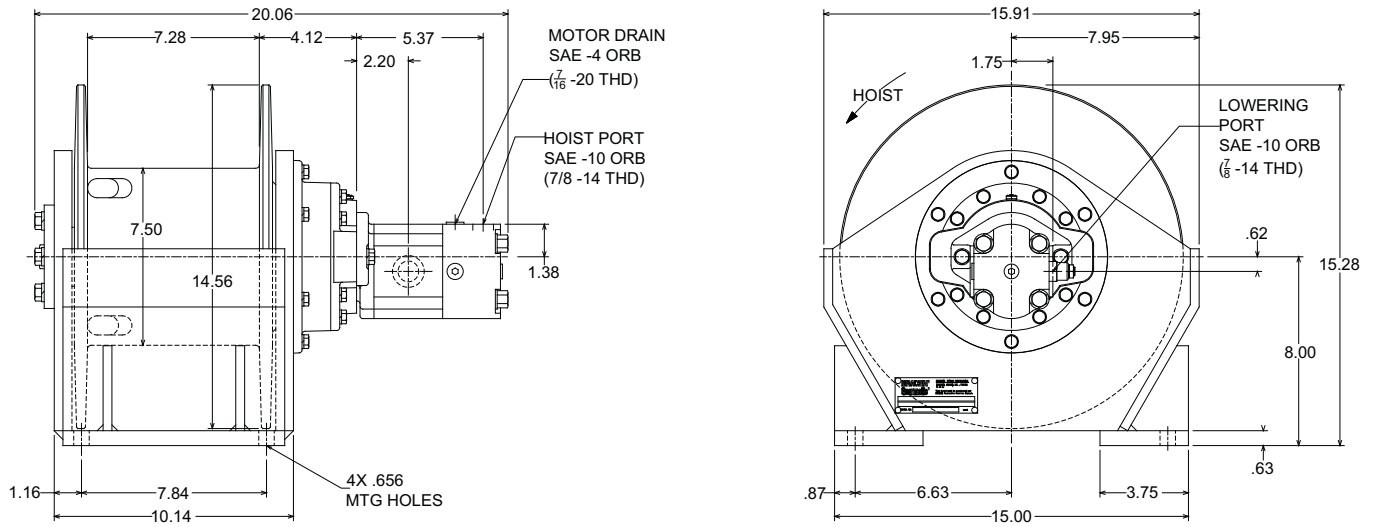

NOTE:Other motor options available as special order

MOTORS 020, 029, & 039

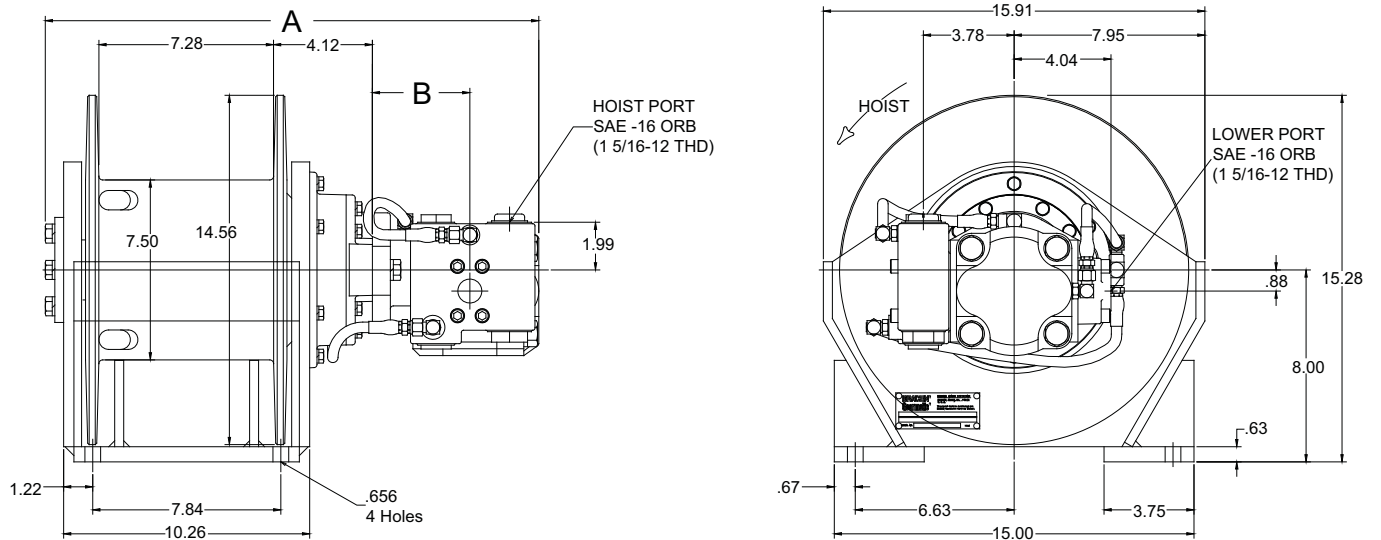

MOTOR	A	B
020	20.58	4.07
029	21.08	4.32
039	21.08	4.32

THEORY OF OPERATION

DESCRIPTION OF HOIST

The hoist has four basic component parts:

1. Hoist base
2. Hydraulic motor group
3. Brake cylinder and motor adapter
4. Cable drum with gear train

The hydraulic motor is bolted to the motor support which in turn is bolted to the brake cylinder and the base. The motor end of the drum, running on a ball bearing, is supported by the brake cylinder. The other end of the drum runs on a ball bearing on the support bolted to the base. The ring gear for the planetary gear train is machined into the drum's inside surface.

HOIST OPERATION

The hydraulic motor drives the sun gear of the primary planetary gear set through the splined inner race of the brake clutch. When driven by the sun gear, the primary planet gears walk around the ring gear in the drum and drive the primary planet carrier.

The primary planet carrier drives the output planet sun gear which, in turn drives the output planet gears. The output planet carrier is splined to the bearing support and cannot rotate. Therefore, as the output planet gears are driven by the sun gear, they will drive the ring gear/drum.

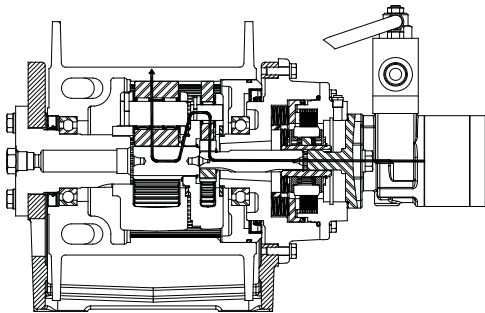

NOTE: The special order 07 (7:1) gear ratio has only one planetary gear set

Dual Brake System – Description

The dual brake system consists of a dynamic brake system and a static brake system.

The dynamic brake system has two operating components:

1. Brake valve assembly
2. Hydraulic motor

The brake valve is basically a counterbalance valve with improved metering. It contains a check valve to allow free flow of oil to the motor in the hoisting direction and a pilot operated, spring-loaded spool valve that blocks the flow of oil out of the motor when the control valve is placed in neutral. When the control valve is placed in the lowering position, the spool valve remains closed until sufficient pilot pressure is applied to the end of the spool to shift it against spring pressure and open a passage. After the spool valve cracks open, the pilot pressure becomes flow-dependent and modulates the spool valve opening which controls the lowering speed.

The static brake system has three operating components:

1. Spring Applied, Multiple Friction Disc Static Brake
2. Brake Clutch Assembly
3. Hydraulic Piston and Cylinder

NOTE: Some special order models have a solid hub for brake effective both directions.

The static brake is released by the brake valve pilot pressure at a pressure lower than that required to open the pilot operated spool valve. This sequence assures that dynamic braking takes place in the brake valve and that little, if any, heat is absorbed by the friction brake.

HYDRAULIC CIRCUIT

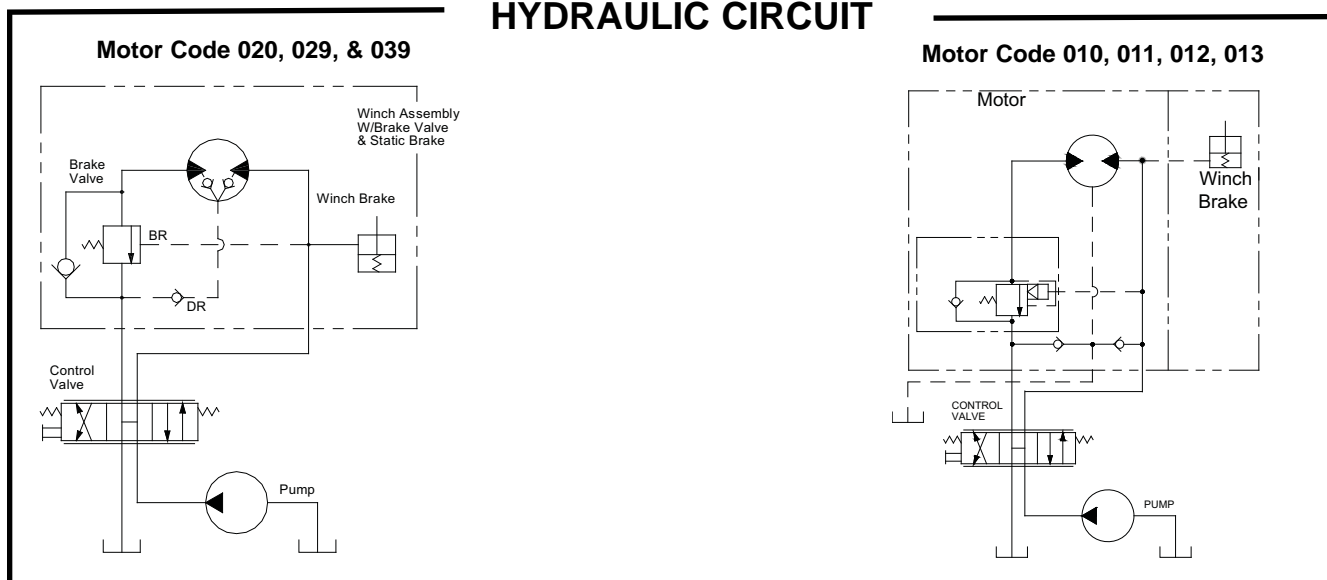

The friction brake is a load holding brake only and has nothing to do with dynamic braking or rate of descent of a load.

The brake clutch is splined to the primary sun gear shaft between the motor and the primary sun gear. It will allow this shaft to turn freely in the direction to raise a load and lock up to force the brake discs to turn with the shaft in the direction to lower a load.

The hydraulic cylinder, when pressurized, will release the spring pressure on the brake discs, allowing the brake discs to turn freely.

Dual Brake System – Operation

When hoisting a load, the brake clutch which connects the motor shaft to the primary sun gear, allows free rotation. The sprag cams lay over and permit the inner race to turn free of the outer race, see figure 2. The static brake remains fully applied. The hoist, in hoisting, is not affected by any braking action.

When the hoisting operation is stopped, the load attempts to turn the primary sun gear in the opposite direction. This reversed input causes the sprag cams to instantly roll upward and firmly lock the shaft to the fully engaged friction brake.

When the hoist is powered in reverse to lower the load, the motor cannot rotate until sufficient pilot pressure is present to open the brake valve. The friction brake within the hoist will completely release at a pressure lower than that required to open the brake valve. The extent to which the brake valve opens will determine the amount of oil that can flow through it and the speed at which the load will be lowered. Increasing the flow of oil to the hoist motor will cause the pressure to rise and the opening in the brake valve to enlarge, speeding up the descent of the load. Decreasing this flow causes the pressure to lower and the opening in the brake valve to decrease thus slowing the descent of the load.

When the control valve is shifted to neutral, the pressure will drop and the brake valve will close, stopping the load. The static brake will engage and hold the load after the brake valve has closed.

When lowering a load very slowly for precise positioning little or no oil flow actually occurs through the hoist motor. The pressure will build up to a point where the brake will release sufficiently to allow the load to rotate the motor through its own internal leakage. This feature results in a very slow speed and extremely accurate positioning.

The friction brake receives very little wear in the lowering operation. Most of the heat generated by the lowering and stopping of a load is absorbed by the hydraulic oil where it can be readily dissipated.

HOIST AND WIRE ROPE INSTALLATION

1. The hoist should be mounted with the centerline of the cable drum in a horizontal position. The mounting plane of the hoist may be rotated in any position around this centerline providing the vent in the motor adapter is above the centerline of the cable drum. The vent should be as close to top dead center as possible.
2. When mounting the hoist, use all four (4) mounting holes and grade eight (8) bolts and nuts. Evenly tighten the nuts to the torque in the "Recommended Torque" chart.

Refer to "Dimensional Drawing" for bolt hole size and pattern.

The hoist must be mounted on a surface that will not flex when the hoist is in use, and cause binding of the gear train. Binding in the gear train will result in accelerated wear and heat. Also, the mounting surface must be flat with ± 0.020 in. (.5mm). If necessary, install shims under the hoist mounting pads to achieve even mounting.

3. The hydraulic lines and components that operate the hoist should be of adequate size to assure minimum back pressure at the hoist. The back pressure at the motor must not exceed 50 psi (345 kPa) to maintain full system design braking and optimum motor seal life.

The hoist directional control valve must be a three position four way valve with a motor spool such that when the valve is in the center position both work ports are open to tank (open center, open port).

4. High quality hydraulic oil is essential for satisfactory performance and long hydraulic system component life.

Oil having 150 to 330 SUS viscosity at 100° F (38° C) and viscosity index of 100 or greater will give good results under normal temperature conditions. The use of an oil having a high viscosity index will minimize cold start trouble and reduce the length of warm-up periods. A high viscosity index will minimize changes in viscosity with corresponding changes in temperature.

Maximum cold weather start-up viscosity should not exceed 5,000 SUS with a pour point at least 20° F (-7°C) lower than the minimum ambient temperature.

Under continuous operating conditions the temperature of the oil at any point in the system must not exceed 180°F (82°C). 120°F (49°C) to 140°F (60°C) is generally considered optimum.

In general terms:

For continuous operation at ambient temperatures between 50°F (10°C) and 110°F (43°C), use SAE 20W; for continuous operation between 10°F (-12°C) and 90°F (32°C), use 10W; for applications colder than 10°F (-12°C), contact the BRADEN Service Department. The use of multi-viscosity oils is generally not recommended.

5. The hydraulic oil filter should have a 10 micron nominal rating and be full flow type; or one in accordance with recommendations of the pump manufacturer.
6. The vent plug in the motor adapter must be located close to top dead center as possible. If the hoist is mounted on a pivoting surface, the vent plug must remain above the centerline of the cable drum to prevent gear oil leakage.
7. Refer to "Dimensional Drawing" for relationship between drum rotation and which port is pressurized.

WIRE ROPE INSTALLATION

Since the static brake on this hoist is "effective both directions", cable can be wound onto the drum in either direction without any modifications to the hoist. The cable drum has two anchor pockets to accommodate this. Take the free end of the wire rope and insert it through the small opening of the anchor pocket you are going to use. Loop the wire rope and push the free end about three-fourths of the way back through the pocket. Install the cable anchor with the small end toward the drum, then pull the slack out of the wire rope. The cable anchor will slip into the pocket and secure the wire rope to the drum. A minimum of five (5) wraps of wire rope should remain on the cable drum at all times. Refer to "General Safety Recommendations" for additional information.

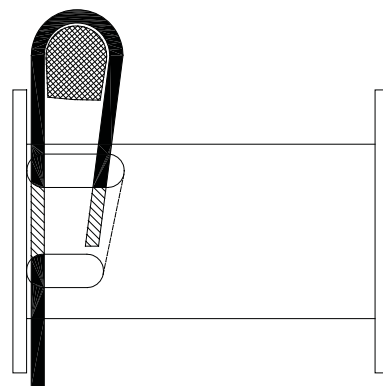

The standard cable anchor wedge supplied with the hoist is intended for 5/16 to 1/2 in. (8 to 13 mm) wire rope.

PREVENTIVE MAINTENANCE

A regular program of preventive maintenance for your planetary hoist is strongly recommended to minimize the need for emergency servicing and promote safe, reliable hoist operation.

Field experience supported by engineering tests, indicates the three (3) service procedures listed below are the **MOST** critical to safe, reliable hoist operation and must be observed.

- **Regular Gear Oil Changes** - initial break-in oil change after 250 hours (2 Months), then every 1000 hours or six (6) months thereafter.
- **Use of Proper Gear Oil** - recommended type for prevailing ambient temperature. See chart on page 10
- **Periodic Disassembly and Inspection of All Wear Items** - in compliance with American National Standards Institute (ANSI) specification B30.5c 1987 and American Petroleum Institute (API) recommended practice RP 2D section 3.

The following minimum service intervals are specified for operating hours of the prime mover.

1. Oil Level

The gear oil level should be checked every 200 operating hours, once per month, when an oil leak is spotted, or whichever occurs first. To check the oil level, remove the large plug located in the center of the drum support. The oil should be level with the bottom of this opening. If additional oil is needed, refer to "Recommended Planetary Gear Oil".

2. Oil Change

The gear oil should be changed after the first one hundred (100) hours of operation, then every 1,000 operating hours or six (6) months, whichever occurs first. The gear oil must be changed to remove wear particles that impede the reliable and safe operation of the brake clutch and erode bearings, gears and seals. Failure to change gear oil at these suggested minimum intervals may contribute to intermittent brake slippage which could result in property damage, severe personal injury or death.

The gear oil should also be changed whenever the ambient temperature changes significantly and an oil from a different temperature range would be more appropriate. Oil viscosity with regard to ambient temperature is critical to reliable brake operation. Make certain that the gear oil viscosity used in your hoist is correct for your prevailing ambient temperature. Failure to use the proper type and viscosity of planetary gear oil may contribute to brake slippage which could result in property damage, severe personal injury or death. Refer to "Recommended Planetary Gear Oil" for additional information.

3. Vent Plug

The vent plug is located in the motor adapter. It is very important to keep this vent clean and unobstructed. Whenever gear oil is changed remove vent plug, clean in solvent and reinstall.

Do not paint over the vent or replace with a solid plug.

4. Hydraulic System

The original filter element should be replaced after the first fifty (50) hours of operation, then every 500 operating hours or three (3) months, or in accordance with the equipment manufacturer's recommendations.

5. Wire Rope

Inspect entire length of wire rope according to wire rope manufacturer's recommendations.

6. Mounting Bolts

Tighten all hoist base mounting bolts to recommended torque after the first one hundred (100) hours of operation, then every 1000 operating hours or six (6) months, whichever occurs first.

7. Warm-up Procedure

A warm-up procedure is recommended at each start-up and is essential at ambient temperatures below +40°F (4°C). The prime mover should be run at its lowest recommended RPM with the hydraulic hoist control valve in neutral allowing sufficient time to warm up the system. The hoist should then be operated at low speeds, hoist and lower, several times to prime all lines with warm hydraulic oil, and to circulate gear lubricant through the planetary gear sets

⚠ WARNING ⚠

Failure to properly warm up the hoist, particularly under low ambient temperature conditions, may result in temporary brake slippage due to high back pressures attempting to release the brake, which could result in property damage, severe personal injury or death.

8. Recommended Planetary Gear Oil

Field experience, supported by extensive engineering tests, indicates the use of the proper planetary gear oil is essential to reliable and safe operation of the brake and obtaining long gear train life.

For simplicity, we have listed readily available products in each temperature range which has been tested and found to meet our specifications. This is not to say that other lubricant brands would not perform equally as well.

If the following lubricant brands are not available in your area, make certain your lubricant vendor supplies you with oil that is equivalent to those products listed below.

Planetary winches are factory filled with Exxon Spartan EP 150 or equivalent.

9. Periodic Teardown/ Inspection

We recommend that the hoist be disassemble for a thorough inspection of all wear items every 2,000 hours of operation or twelve (12) months, whichever occurs first.

! WARNING !

Failure to use the proper type and viscosity of planetary gear oil may contribute to intermittent brake slippage which could result in property damage, severe personal injury or death. Some gear lubricants contain large amounts of EP (extreme pressure) and anti-friction additives which may contribute to brake slippage and damage to brake friction discs or seals. Oil viscosity with regard to ambient temperatures is also critical to reliable brake operation. Our tests indicate that excessively heavy or thick gear oil may contribute to intermittent brake slippage. Make certain that the gear oil viscosity used in your hoist is correct for your prevailing ambient temperature.

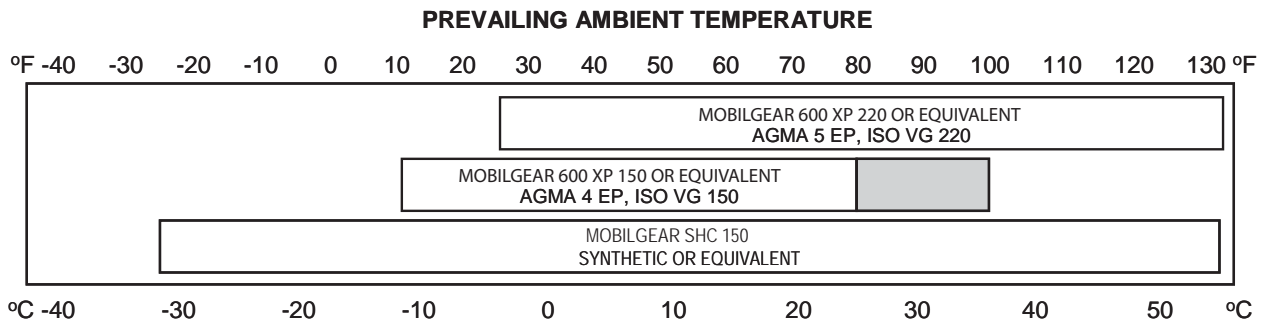

i **NOTE:** SHADED TEMPERATURE RANGE IN THE CHART ABOVE NOT RECOMMENDED FOR SEVERE APPLICATIONS SUCH AS: OFFSHORE CRANES, SUSTAINED FAST DUTY CYCLES OR FREQUENT LIFTING.

Planetary hoists are factory filled with Mobilgear 600 XP 150, or equivalent. Consult your oil supplier for other equivalent oils if required.

Mobil	Shell	Chevron	Texaco
Mobilgear 600 XP 150	Omala 150	Gear Compounds EP 150	Meropa 150
Mobilgear 600 XP 220	Omala 220	Gear Compounds EP 220	Meropa 220

Gear Oil Capacity
-01 and -02 drums = 2 Pints (0.9 L)

TROUBLE SHOOTING

TROUBLE	PROBABLE CAUSE	REMEDY
<p>A.</p> <p>Hoist will not pull maximum load.</p>	<ol style="list-style-type: none"> 1. System relief valve may be set too low. 2. If this trouble occurs suddenly after working at maximum pull, a particle of dirt may be lodged under the system relief valve, holding it partially open. If this is the cause, a considerable loss in line speed may be noticed as the load on the cable is increased. 3. If the pump is belt driven, the belt may be slipping. 4. The oil level in the reservoir may be too low. The suction line may be restricted or have an air leak causing cavitation at the inlet port. This will cause the pump to make a whining noise. 5. The hoist may be mounted on an uneven or flexible surface which causes distortion of the hoist base and binding of the gear train. Binding in the gear train will absorb horsepower needed to generate the rated line pull and cause heat. 6. Be certain hydraulic system temperature is not more than 180°F (82°C). Excessive hydraulic oil temperatures increase motor internal leakage and reduce motor performance. 7. Hoist line pull rating is based on 1st layer of wire rope. Expected line pull may be in excess of hoist rating. 8. After all the causes listed above have been investigated and it is found that the hoist will stall at maximum pressure without developing the maximum pull on the bare drum, the trouble may be in the hoist. 	<p>Install a pressure gauge in the haul-in port and apply a stall pull on the hoist. If pressure is low, increase relief valve setting until recommended pressure is obtained.</p> <p>NOTE: <i>If pressure does not increase in proportion to adjustment, relief valve may be contaminated or worn out. In either case, the relief valve may require disassembly or replacement.</i></p> <p>Remove relief valve, disassemble and clean parts thoroughly in a suitable solvent. Reassemble and install relief valve. Reset pressure according to specifications.</p> <p>Check belts when pump is at full PSI (kg/cm²) (stall pull on hoist). Tighten belts if they are found to be slipping.</p> <p>Check oil level in the reservoir. Check the suction line for damage, externally and internally. Replace suction line if necessary.</p> <p>Reinforce mounting surface.</p> <p>If necessary, use steel shim stock to level hoist.</p> <p>First loosen, then evenly retighten all hoist mounting bolts to recommended torque.</p> <p>Same as remedy for A-5.</p> <p>Same as remedy for B-4</p> <p>Refer to hoist performance charts for additional information.</p> <p>Install a pressure gauge in the motor haul-in port and apply a stall pull on the hoist. If the pressure is up to maximum and the bare drum line pull is less than the specified line pull, the trouble will be in the hoist.</p> <p>Disassemble hoist according to disassembly instructions and check that gear train turns freely. If gear train is found to be satisfactory, inspect the hydraulic motor, according to the service instructions for the hydraulic motor.</p>

TROUBLE SHOOTING

TROUBLE	PROBABLE CAUSE	REMEDY
A.	9. Rigging and sheaves not operating efficiently.	Perform rigging and sheave service as recommended by manufacturer.
B. Considerable reduction in line speed.	<ol style="list-style-type: none"> 1. Same as A-2. 2. Same as A-4. 3. Same as A-6. 4. If this trouble has increased gradually, the hydraulic pump or hoist motor may be worn. 	<p>Same as remedy for A-2. Same as remedy for A-4. Same as remedy for A-5 & B-4.</p> <p>Remove and inspect pump. If satisfactory, consult the disassembly instructions for the hoist and remove and inspect the motor according to the service instructions for the hydraulic pump.</p>
C. Reverse speed is slower than forward speed.	<ol style="list-style-type: none"> 1. Control valve may be restricted in its travel. 2. Same as A-1. 3. Oil may be too thick causing a high resistance to rotation at the brake plates and causing the relief valve to by-pass. 4. Same as F-1. 	<p>Check the travel of the control valve spool. The spool travel should be the same in both directions. Same as remedy for A-1. Follow warm-up procedure in "Preventive Maintenance" section.</p> <p>Same remedy for F1.</p>
D. Brake will not hold when control valve is returned to neutral after lifting a load.	<ol style="list-style-type: none"> 1. Excessive system back pressure acting on the brake release port. 2. Friction brake will not hold due to worn or damaged brake disks. 	<p>Install a pressure gauge at the "pay-out" port of the hydraulics motor. Operate the pump at full throttle and monitor pressure in "neutral" and haul-in positions. If the pressure is greater than 50 PSI, check for restrictions in the return line from the hoist to the control valve and the control valve to the reservoir.</p> <p>Disassemble hoist to inspect/replace worn parts.</p>
E. Brake will not control or stop the load when lowering.	<ol style="list-style-type: none"> 1. Same as D-2 or 2. 2. Hoist is being overloaded. 3. After the causes listed above have been investigated and found to be satisfactory, the trouble may be in the hoist. 	<p>Same as remedy for D-1 or 2. Install a pressure gauge at the haul-in port and apply a stall pull on the hoist. If the pressure is higher than the maximum specified PSI, reduce the pressure.</p> <p>Disassemble the brake assembly according to the disassembly instructions. Inspect the brake springs, and brake plates.</p>

TROUBLE SHOOTING

TROUBLE	PROBABLE CAUSE	REMEDY
<p>F.</p> <p>The hoist will not lower the load or not lower the load smoothly.</p>	<ol style="list-style-type: none"> 1. The friction brake may not be releasing as a result of a defective brake cylinder seal. NOTE: <i>If the brake cylinder seal is defective you will usually notice oil leaking from the hoist vent plug.</i> 2. Friction brake will not release as a result of damaged brake disks. 3. Same as B-4. 4. Same as A-3. 5. Same as A-5. 6. Control valve handle being operated too quickly. 7. Insufficient gear oil in cable drum. 8. Control valve does not have good metering characteristics. 	<p>Disassemble and inspect the brake cylinder seal.</p> <p>Disassemble brake to inspect brake disks.</p> <p>Same as remedy for B-4. Same as remedy for A-3. Same as remedy for A-5.</p> <p>Operate control valve smoothly when starting and stopping a load. Conduct operator training as required.</p> <p>Remove oil level plug and check oil level. Fill to proper level.</p> <p>See "Hoist Installation" section for control valve specifications.</p>
<p>G.</p> <p>The hoist runs hot.</p>	<ol style="list-style-type: none"> 1. Same as A-5. 2. Be certain that the hydraulic system temperature is not more than 180 degrees F. Excessive hydraulic oil temperatures may be caused by: <ol style="list-style-type: none"> A. Plugged heat exchanger. B. Too low or too high oil level in hydraulic reservoir. C Same as A-1. D Hydraulic pump not operating efficiently. 3. Excessively worn or damaged internal hoist parts. 4. Same as F-7. 	<p>Same as remedy for A-5.</p> <p>Thoroughly clean exterior and flush interior. Fill/drain to proper level.</p> <p>Same as remedy for A-1. Remove and inspect pump.</p> <p>Check suction line for damage. If pump is belt driven, belts may be slipping. Replace/tighten belts. Same as remedy for F-7.</p>
<p>H.</p> <p>Hoist "chatters" while raising rated load.</p> <p>-</p>	<ol style="list-style-type: none"> 1. Same as A-1. 2. Same as B-4. 3. Hydraulic oil flow to motor may be too low. 4. Same as F-6. 	<p>Same as remedy for A-1. Same as remedy for B-4. Increase pump rpm.</p> <p>Same as remedy for F-6.</p>

Braden/ Gearmatic BG6A & BG6B Components

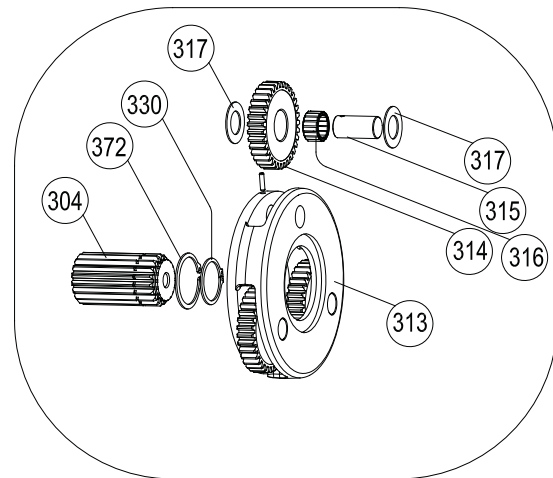
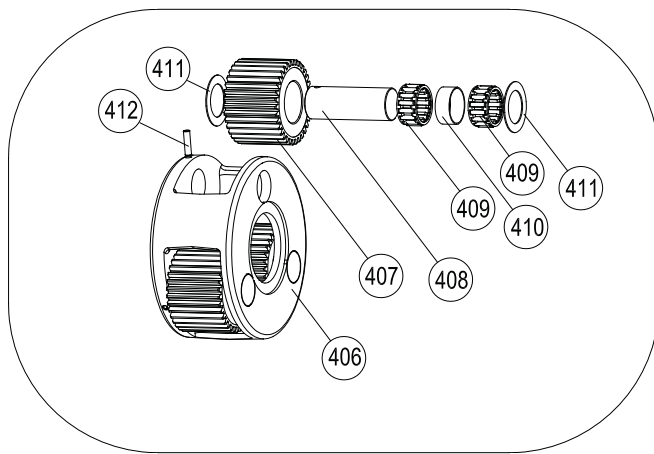
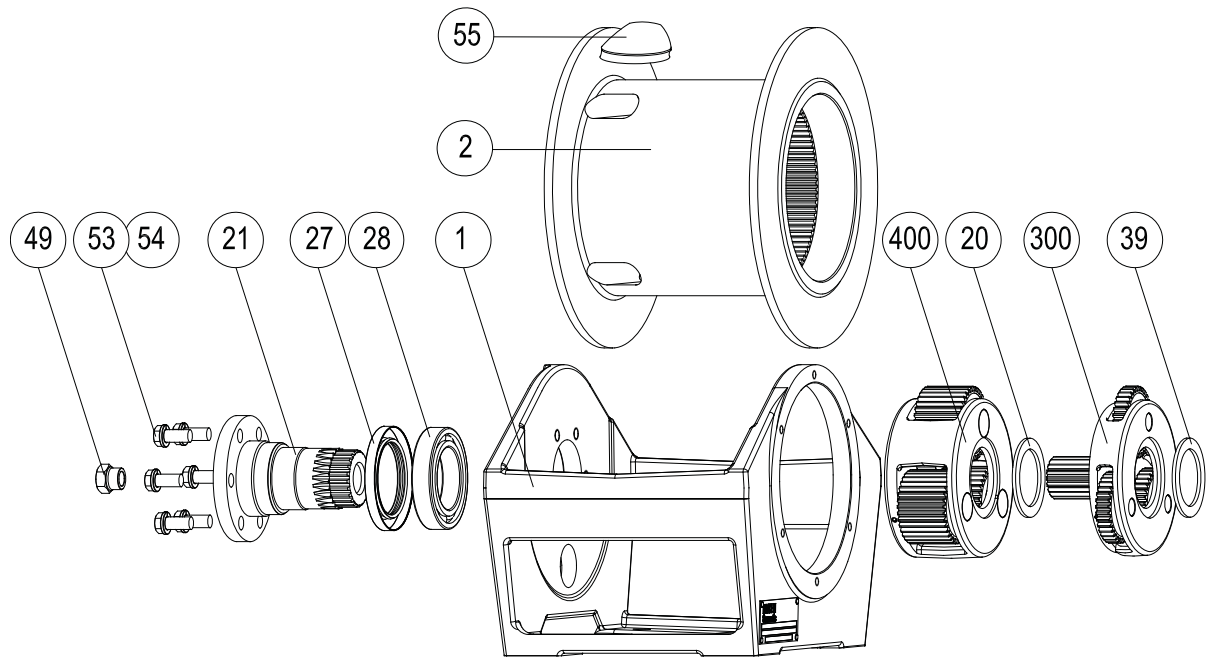

ITEM	DESCRIPTION	QTY
1	BASE	1
2	CABLE DRUM	1
3	CABLE DRUM CLOSURE	1
5	PRIMARY SUN GEAR	1
19	THRUST RACE	1
20	THRUST RACE	1
21	BEARING SUPPORT	1
27	OIL SEAL	1
28	BALL BEARING	2
29	SNAP RING	1
31	O-RING	1
32	OIL SEAL	1
33	LOCKWASHER	6
34	CAPSCREW	6

ITEM	DESCRIPTION	QTY
49	16166-8 PLUG	1
51	DRIVE SCREW	4
53	LOCKWASHER	6
54	CAPSCREW	6
55	CABLE WEDGE	1
70	INPUT SHAFT	1
100	BRAKE CLUTCH ASY.	1
222	BRAKE CYLINDER/BG6B	1
223	MOTOR ADAPTER	1
233	LOCKWASHER	8
234	CAPSCREW	8
235	SPRING PLATE	1
236	U-CUP SEAL	1
237	RELIEF VALVE 1-5 PSI	1

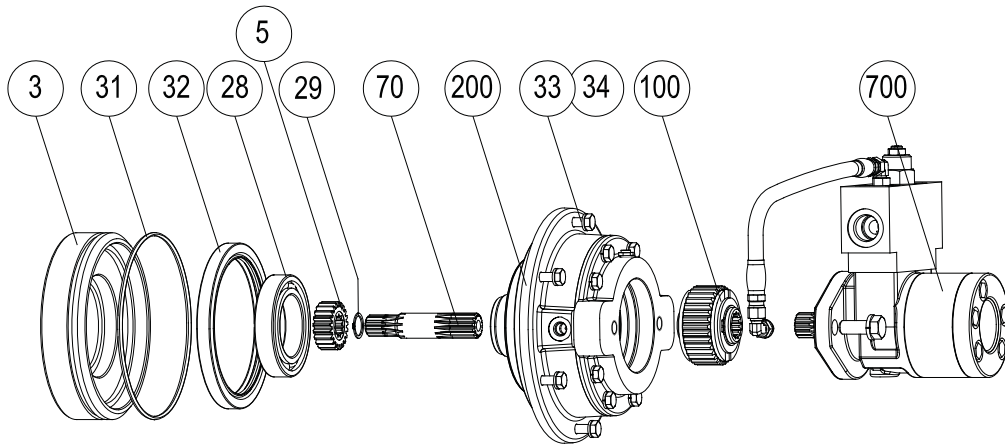

REFER TO MATERIAL LIST FOR PART NO. LISTINGS

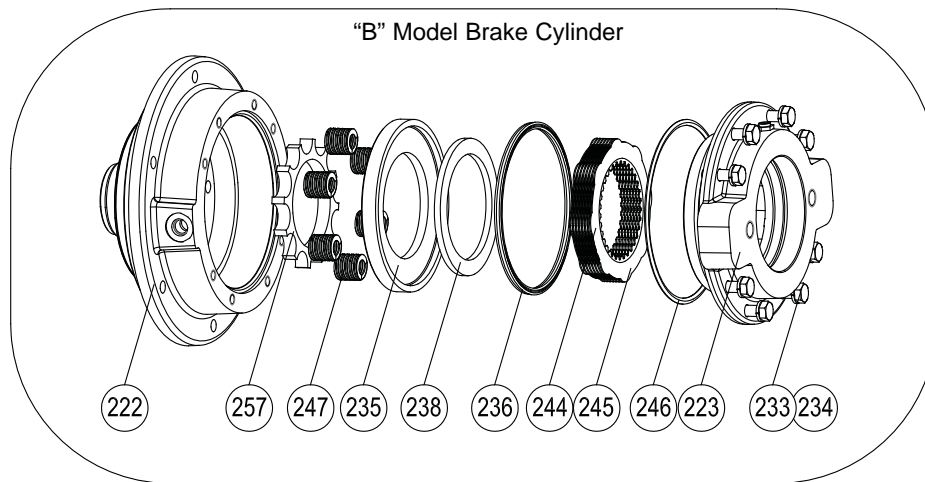

*= QUANTITY OF PART DISPLAYED MAY NOT BE ACCURATE FOR YOUR APPLICATION. CONSULT RESPECTIVE MATERIAL LIST FOR ACCURATE QUANTITY'S

ITEM	DESCRIPTION	QTY
238	BRAKE PLATE SPACER	1
244	FRICITION DISC	7*
245	BRAKE DISC	8*
246	O-RING	1
247	SPRING	6*
257	SPRING LOCATOR	1
300	PRIMARY PLANET CARRIER ASY.	1
304	OUTPUT SUN GEAR	1
313	PRIMARY PLANET CARRIER	1
314	PRIMARY PLANET GEAR	3
315	PLANET GEAR SHAFT	3
316	BEARING ROLLER	3
317	THRUST WASHER	6
318	ROLLPIN	3

ITEM	DESCRIPTION	QTY
330	1941006 SNAP RING	1
372	SNAP RING	1
400	OUTPUT PLANET CARRIER ASY.	1
406	OUTPUT PLANET CARRIER	1
407	OUTPUT PLANET GEAR	3
408	OUTPUT PLANET GEAR SHAFT	3
409	ROLLER BEARING	6
410	BEARING SPACER	3
411	THRUST BEARING	6
412	ROLLPIN	3
100	BRAKE/CLUTCH ASSY/GH5/PD5	1
200	BRAKE CYLINDER ASSY	1
300	PRIMARY PLANET CARRIER ASSY	1
400	OUTPUT PLANET CARRIER ASSY	1
700	HYD MOTOR GROUP	1

HOIST SERVICE

FOREWORD TO HOIST SERVICE

Before any part is removed from the hoist, all service instructions should be read and understood.

Work in a clean, dust free area as cleanliness is of utmost importance when servicing hydraulic equipment.

Inspect all replacement parts, prior to installation, to detect any damage which might have occurred in shipment.

Use only genuine BRADEN replacement parts for optimum results. Never reuse expendable parts such as oil seals and O-rings.

Inspect all machined surfaces for excessive wear or damage...before reassembly operations are begun.

Lubricate all O-rings and oil seals with gear oil prior to installation.

Use a sealing compound on the outside surface of oil seals and a light coat of thread sealing compound on pipe threads. Avoid getting thread compound inside parts or passages which conduct oil.

Thoroughly clean all parts in a good grade of non-flammable safety solvent. Wear protective clothing as required.

Refer to exploded view drawing for item numbers used in service procedures.

- Perform all applicable trouble shooting operations BEFORE disassembling hoist.

⚠ WARNING ⚠

DO NOT CLEAN BRAKE FRICTION DISKS IN SOLVENT. SOLVENT MAY CAUSE DAMAGE TO FRICTION MATERIAL WHICH MAY RESULT IN BRAKE FAILURE AND LOSS OF LOAD CONTROL.

HOIST DISASSEMBLY

1. Disconnect all hoses and fittings at the hoist.

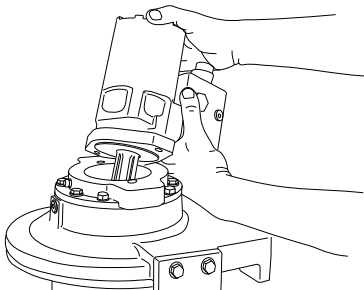

2. Stand the hoist on the bearing support plate. Remove the brake release tube assembly (59) between the brake valve block and the brake cylinder end plate. Remove the capscrews and lockwashers which secure the motor to the motor adapter, and lift the motor out of the motor adapter. Remove and discard the O-ring installed on the pilot of the motor.

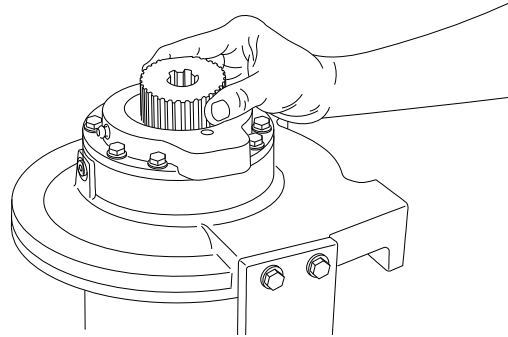

3. Remove the overrunning clutch assembly (100) and sun gear (70) from the hoist.
4. Remove six capscrews (33 & 34) from the the base (1), remove brake cylinder assembly.

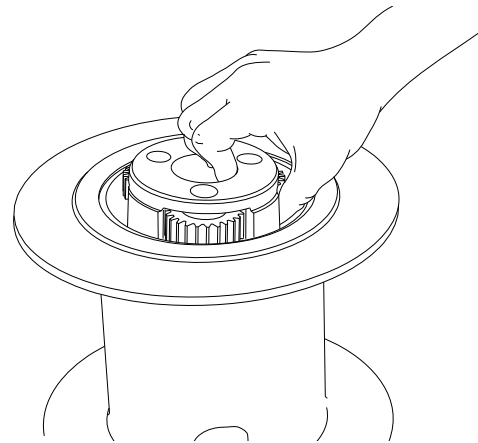

5. Lift out primary sun gear (70). Then lift out cable drum closure (3).
6. Lift out primary planetary gear assembly (300), followed by removing the output planetary assembly (400). Thrustwashers (20 & 39) are set between primary planetary gear and output planetary gear. These are not secured and may fall out upon removal of planetary assemblies.
7. Stand hoist assembly on motor mount flange and remove six drum support capscrews (33, 34, 53, & 54). Remove drum bearing support (21). Drum can now be lifted from base. Drum bearing and seal (27 & 28) are pressed into drum enclosure.

DRUM ASSEMBLY SERVICE

1. Remove the bearing and seal from support end of the drum. Check the ring gear teeth (machined into the inside surface of the drum) for nicks, spalling or excessive wear. Replace the drum if wear is greater than 0.015 in. (0.4 mm) when compared to unworn area of teeth.

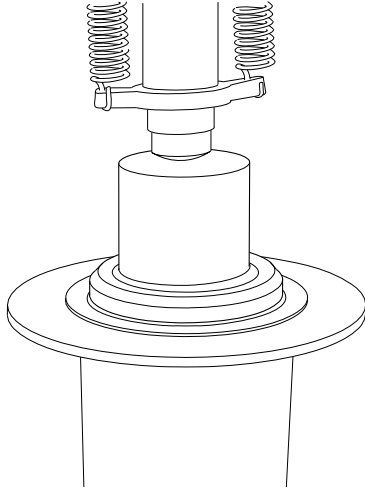

2. Install new bearings in the drum if replacement is necessary. Apply a non-hardening sealant on the outside diameter of each new seal and press the seals into the drum, using a flat plate to avoid distortion.

MOTOR SUPPORT-BRAKE CYLINDER SERVICE

NOTE: Starting mid-year 1996, Braden changed the steel brake separator discs from a splined tooth design to a lobed design. This required a change to the motor support and brake cylinder and the addition of a spring spacer. A hoist with the lobed discs can be identified by a machined groove on the outside diameter of the motor support. When replacing steel brake discs, the motor support or brake cylinder, care must be taken to properly identify the correct parts. Splined discs, and their mating motor support and brake cylinder will remain available as spare parts.

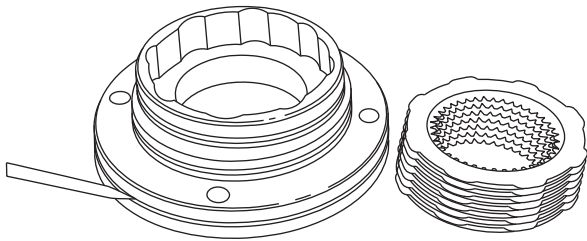

New lobed steel brake separator plates and motor support. Note groove on outside diameter of motor support.

Although most photos in this section show splined discs, all procedures are the same except where specifically noted.

DISASSEMBLY

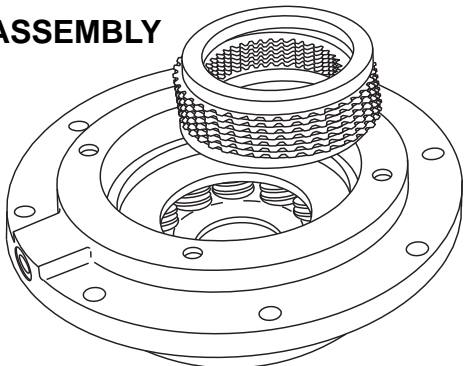

1. After removing the motor support and brake clutch assembly, continue brake cylinder disassembly by removing the spacers, friction brake discs and steel brake discs.

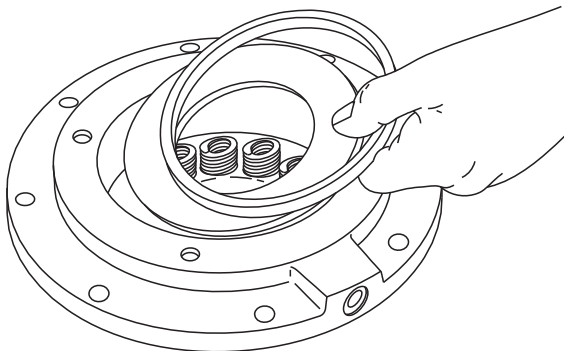

2. Remove the piston back-up ring and pressure plate.

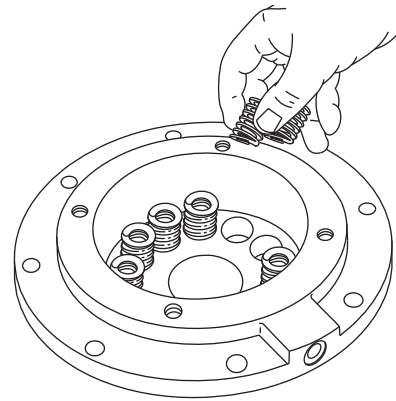

3. Remove the brake springs.

CLEAN AND INSPECT

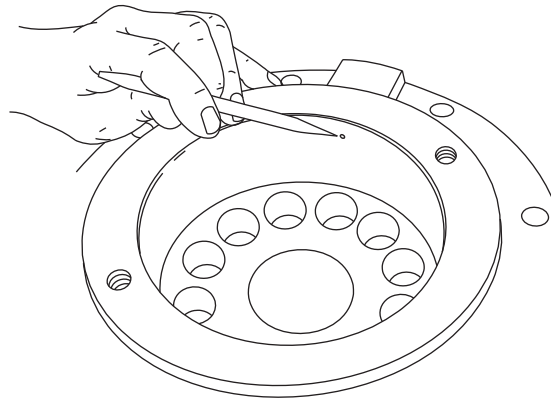

1. Thoroughly clean and inspect all parts at this time. Check brake piston sealing surfaces on brake cylinder and motor support for scoring or wear. Be sure brake release port is free of contamination.

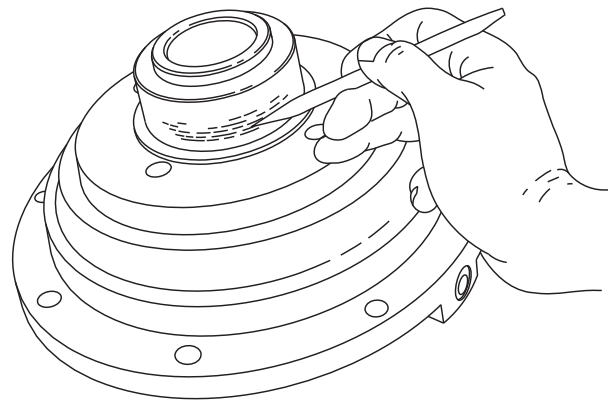

2. Check oil seal and bearing surfaces on brake cylinder for damage or wear.

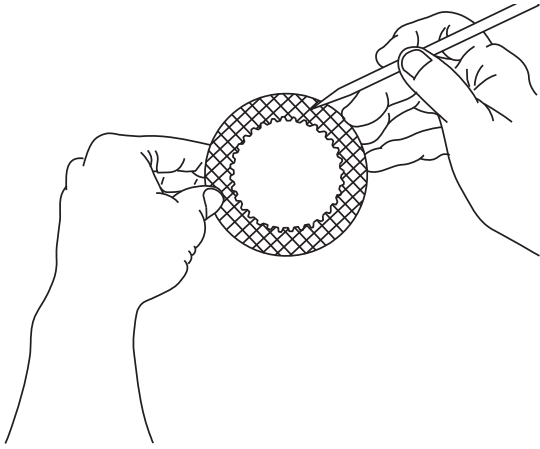

3. Place friction brake disc on flat surface and check for distortion with a straight edge. Friction material should appear even across entire surface with groove pattern visible. Replace friction disc if splines are worn to a point, disc is distorted, friction material is worn unevenly, or groove pattern is worn away.
4. Place steel brake disc on flat surface and check for distortion with a straight edge. Check surface for signs of material transfer or heat. Replace steel disc if splines are worn to a point, disc is distorted or heat discolored.

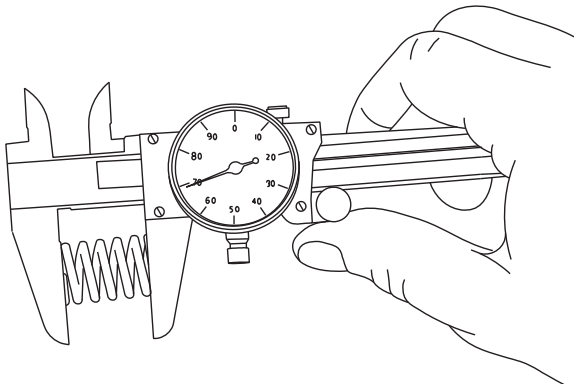

5. Check brake spring free length; minimum free length is 15/16 in. (23.8 mm). Check springs for any sign of cracking or failure. If a brake spring must be replaced for any reason, then ALL brake springs must be replaced.

▲ **CAUTION** ▲

Failure to replace brake springs as a set may result in uneven brake application pressure and repeated brake spring failure.

ASSEMBLY

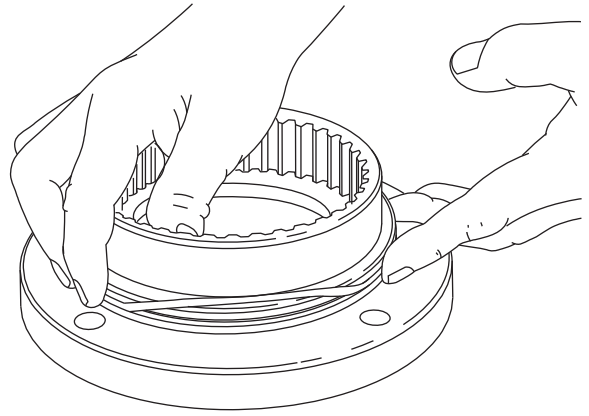

1. Begin assembly by placing motor support on workbench with motor mounting surface down. Install new O-ring and back-up ring as shown.

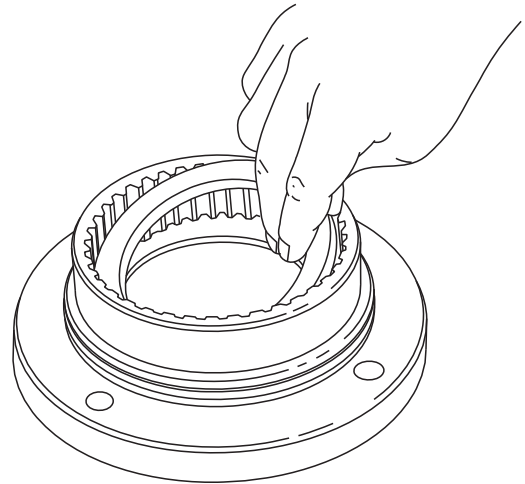

2. Install a brake spacer into the motor support. (**Not required with lobed discs.**)

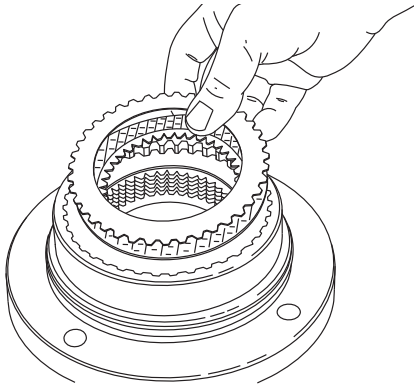

3. Insert first, a steel brake disc against the spacer followed by a friction brake disc then alternate steel and friction discs until seven (7) friction and eight (8) steel discs have been installed. Finish with a steel brake disc on top.

NOTE: It is a good practice to pre-lubricate the discs in light motor oil prior to assembly.

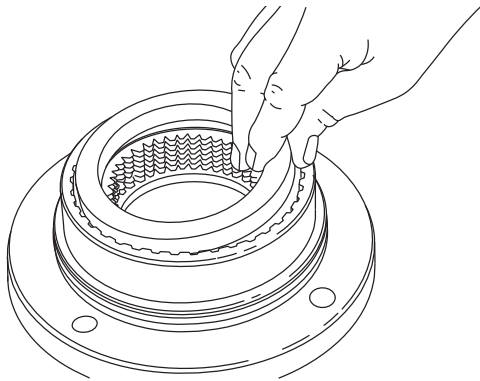

4. Install the remaining brake spacer on top of the last steel brake disc. (This is the only spacer used with lobed discs, except on some of the 67:1 ratio units with the 1.3 displacement motors, two of the spacers are stacked on the brake discs.)

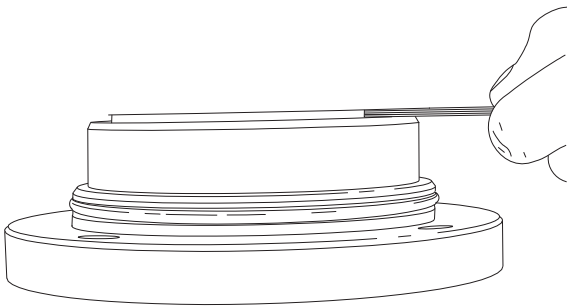

5. To check brake stack height, apply light pressure to the brake spacer. Hold brake spacer down firmly by hand and measure clearance in three places between uppermost motor support flange and brake spacer. Brake spacer must rise above uppermost flange .080 in. (2 mm) maximum and .000 in. (.00 mm). If the gap exceeds the maximum limit, there are too many brake discs in stack-up or the discs are distorted. If the gap is less than the minimum, there are too few discs in stack-up or the discs are worn out.

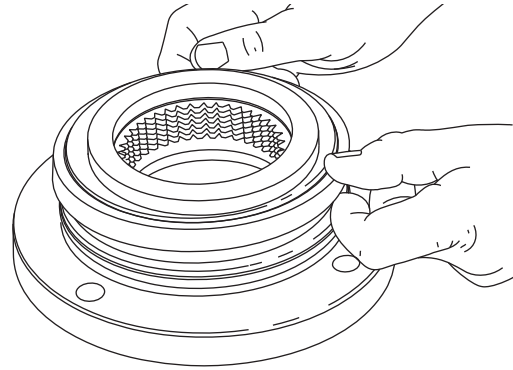

6. Lubricate the brake piston seal and motor support sealing surface with petroleum jelly or hydraulic oil. Install new piston seal to motor support, seal lip down.

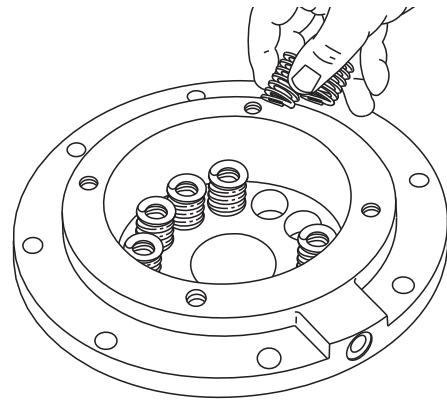

OLDER STYLE BRAKE CYLINDER

7. Install brake springs into brake cylinder

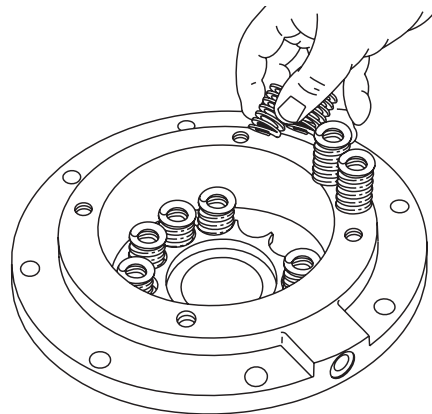

NEW STYLE BRAKE CYLINDER

- 7A. When using the new style brake cylinder without milled spring pockets, install the spring spacer, then the brake springs.

⚠ WARNING ⚠

Always use the molded spring spacer with the new brake cylinder. The brake springs must be properly positioned by the spring spacer. Failure to install the spring spacer may allow the springs to contact each other and become damaged. This could result in loss of load control, property damage, injury or death.

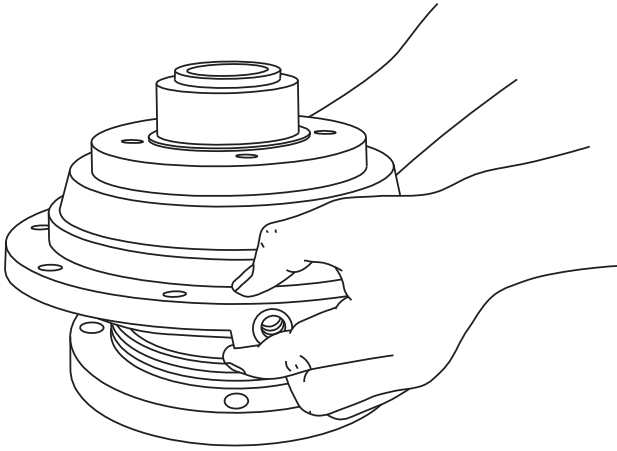

8. Apply petroleum jelly to the entire sealing surface of the brake cylinder and to the piston seal. Install the brake cylinder over the motor support being careful to avoid damaging the piston seal or motor support O-ring. (A press may be necessary to avoid cocking the brake cylinder during installation.)
9. Install motor support capscrews and evenly tighten to recommended torque.

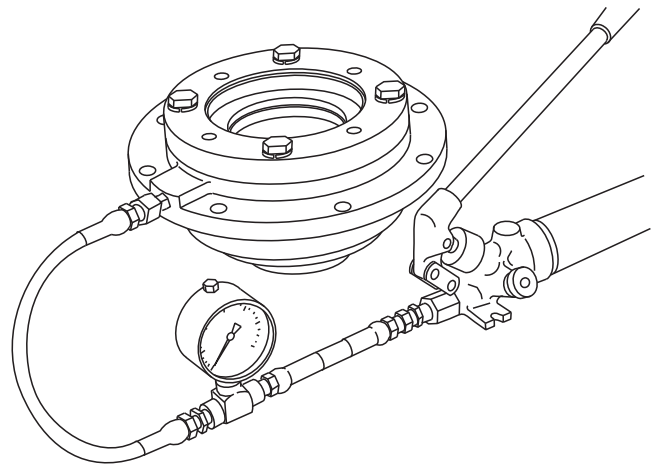

BRAKE CYLINDER PRESSURE TEST

1. Install the -4 J.I.C. fitting into the brake release port. Connect a hand pump with accurate 0-2000 psi (0-13,800 kPa) gauge and shut-off valve to this fitting. Apply 1000 psi (6,900 kPa) to the brake. Close shut-off valve and let stand for five (5) minutes. If there is any loss of pressure in five (5) minutes, the brake cylinder should be disassembled for inspection of the sealing surfaces and brake piston.
2. WHILE PRESSURE IS APPLIED AND THE BRAKE RELEASED, install the brake clutch assembly in the brake pack, short end of the inner race toward motor. Turn the clutch back and forth as you align the outer race splines with the brake disc splines.
3. Release the pressure on the brake cylinder then remove the brake clutch assembly. The brake cylinder assembly is now complete and ready to be installed in the hoist.

BRAKE CLUTCH SERVICE

DISASSEMBLY

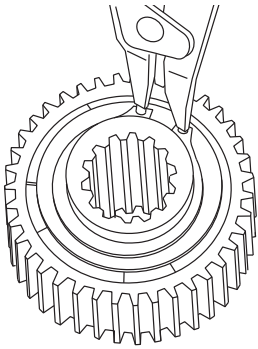

1. Remove the snap ring and sprag bushing retainer from one end only.

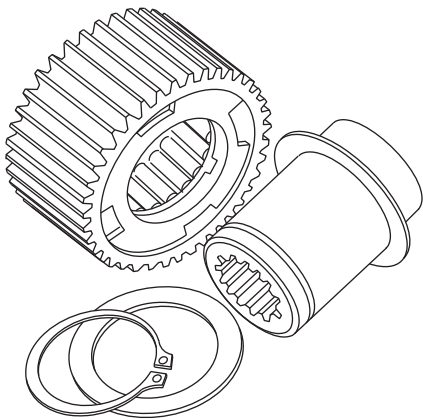

2. Pull the inner race out. Examine the race for scoring, wear or indentations caused by the sprag cams.

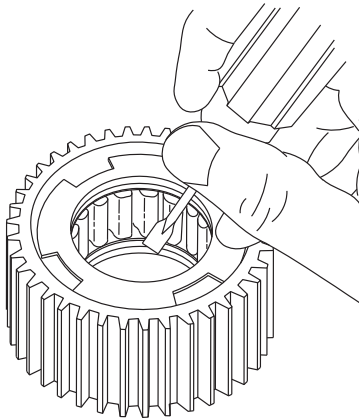

3. Use a screwdriver and mallet to remove the sprag bushing from one end of the outer race. There are four special cut-outs in the bushing for this purpose. Be careful not to damage the bushing inside surface. If a bushing's inside surface is damaged or shows wear, replace it.

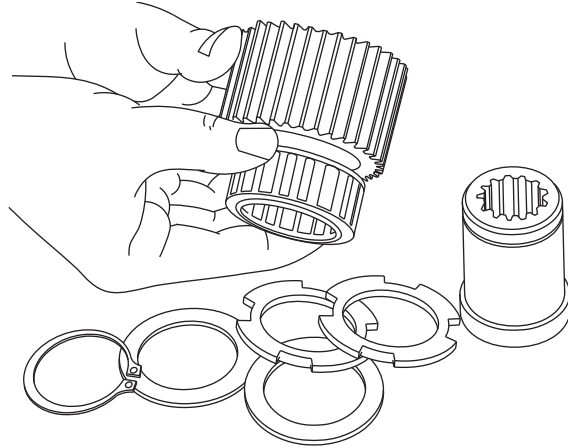

4. Next, slide the sprag clutch out, inspect the sprag clutch closely for abnormal wear, cracks, pitting or corrosion. Check small clips for breakage or bright spots; the signs of excessive wear. Unless the outer race or remaining sprag bushing is damaged or shows excessive wear, there is no need for further disassembly. If disassembly is necessary, remove the bushing according to the procedure covered in Step No. three (3). All brake clutch assembly parts should be thoroughly cleaned and inspected before assembly.

⚠ WARNING ⚠

The polished surfaces of the races and sprag cams must be perfectly smooth to insure positive engagement of the clutch. The slightest defect may reduce brake clutch effectiveness, which may lead to loss of load control and result in property damage, personal injury or death. It is generally recommended to replace the entire brake clutch assembly if any component is defective.

ASSEMBLY

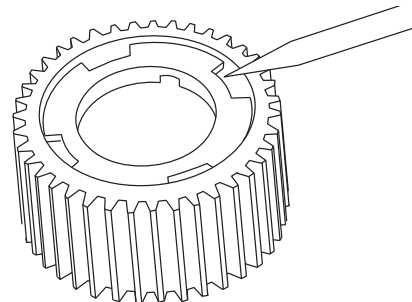

1. Press a sprag bushing into the outer race, using a mechanical or hydraulic press. A flat plate of approximately the same diameter as the bushing flange outside diameter should be placed between the press and bushing during assembly to protect the bushing. Be certain the bushing flange is against the shoulder in the outer race.

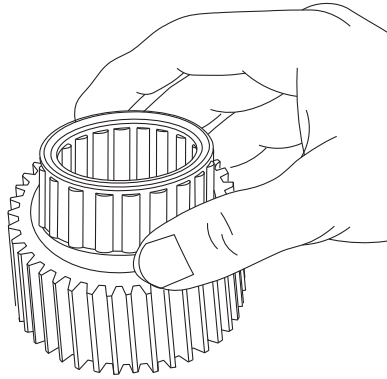

2. Turn the assembly over and install the sprag clutch in the bore of the outer race.
3. Press the remaining bushing into the race. Again, make sure the bushing is against the shoulder.

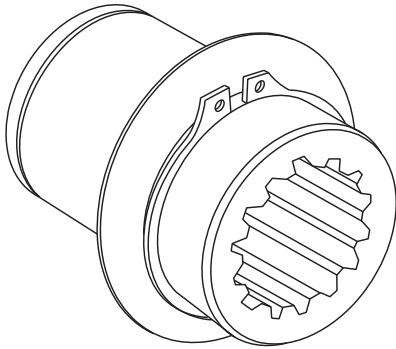

4. Next, install a sprag bushing retainer, then a snap ring on the inner race. Be sure the snap ring is seated in the snap ring groove.

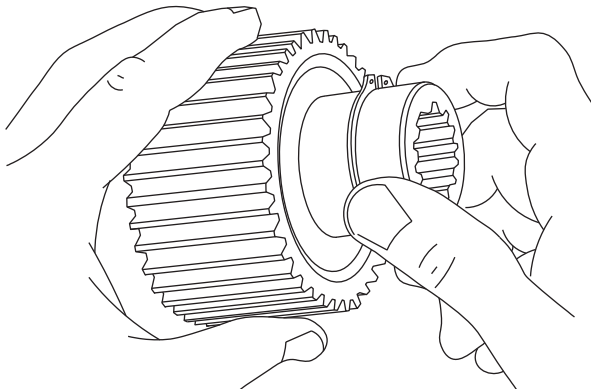

5. Slide the inner race through the bushings and sprag clutch (the race will have to be rotated in the free-wheeling direction to start it through the sprag clutch). If the inner race will not go through the bushings, the bushings have probably been damaged and should be replaced.

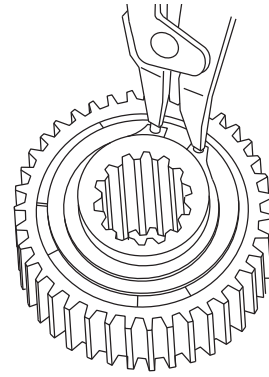

6. Turn the assembly over with the snap ring down. Install the second retainer and snap ring. Make certain the snap ring is seated in the groove properly.

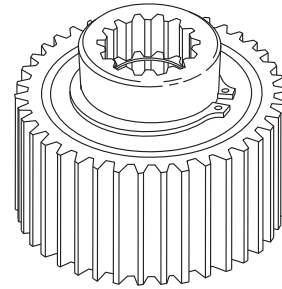

7. This is a completed brake clutch assembly.

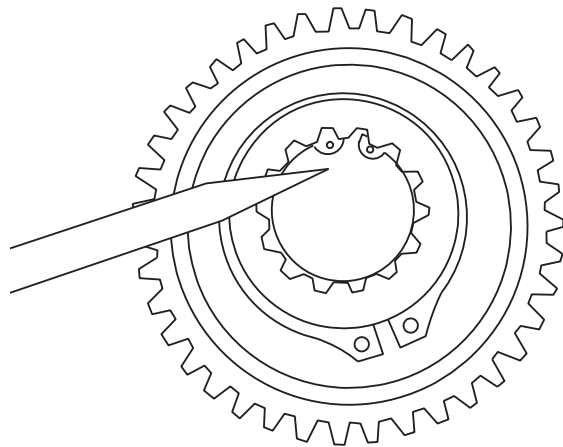

⚠ WARNING ⚠

Be certain the snap ring is seated in the groove in the splined bore of the inner race. This snap ring will keep the brake clutch assembly correctly positioned in the center of the friction brake pack. Binding of the brake or brake failure may occur if this snap ring is omitted.

PLANET CARRIER SERVICE

OUTPUT PLANET CARRIER

DISASSEMBLY

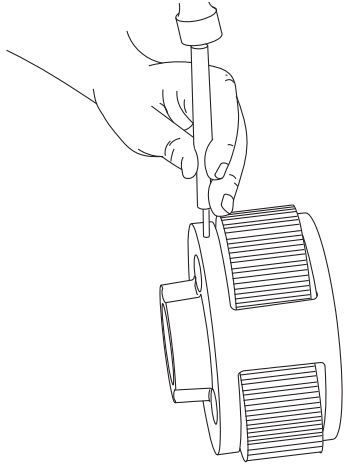

1. Remove the planet gears by driving the roll pins into the center of the planet shafts.

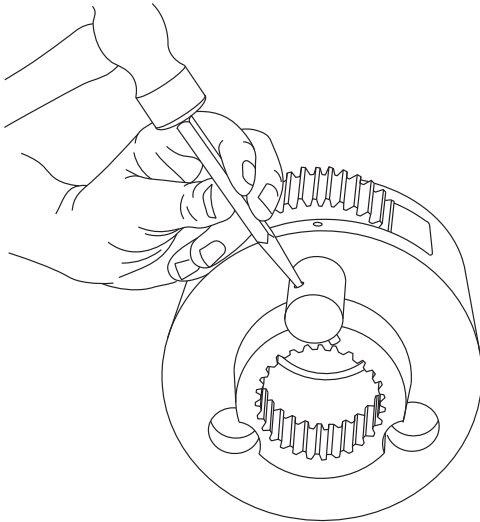

2. Use a punch to drive the roll pins from the planet shafts. Do not reuse the roll pins.

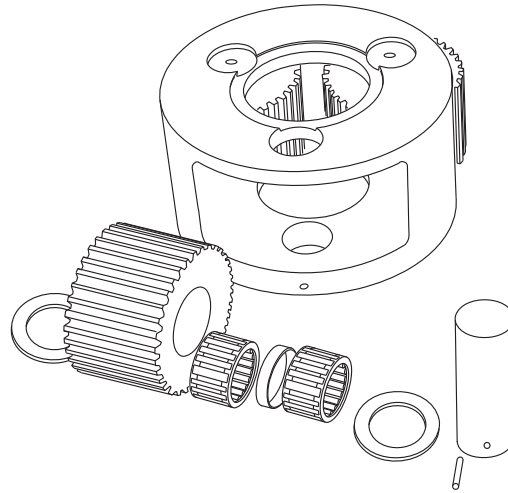

3. Now you can remove the planet shafts, bearings, spacer, thrust washers and gears. Thoroughly clean all parts and inspect for damage and wear. The bearing rollers should not exhibit any irregularities. If the rollers show any sign of spalling, corrosion, discoloration, material displacement or abnormal wear, the bearing should be replaced. Likewise, the cage should be inspected for unusual wear or deformation, particularly the cage bars. If there is any damage that will impair the cage's ability to separate, retain and guide the rollers properly, the bearing should be replaced. The thrust washer contact areas should be free from any surface irregularities that may cause abrasions or friction. The gears and shafts should be inspected for abnormal wear or pitting. Replace if necessary.

ASSEMBLY

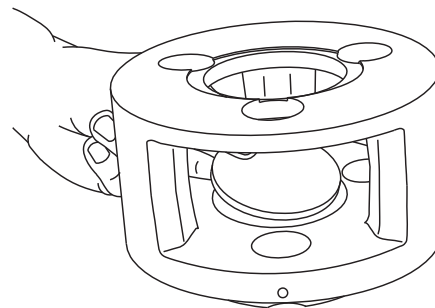

1. Place the output planet carrier on workbench with splined coupling side down. Install output thrust plate in center of carrier.

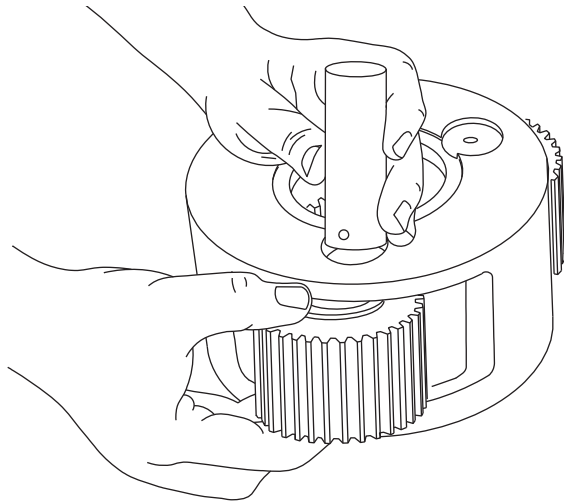

2. Insert two (2) bearings and a bearing spacer into a gear with the spacer between the bearings. Place a thrust washer on each side of the gear and position in a carrier opening. Slide the shaft through the carrier, thrust washer, bearing-gear sub-assembly and remaining thrust washer.

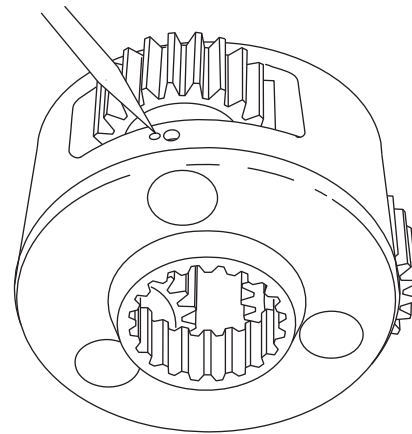

4. Note that the roll pin is slightly recessed in the carrier when properly installed. With a center punch, stake the carrier next to the pin hole as shown. This will distort the hole so the pin will not back out. Repeat these steps for each of the three planet gears.

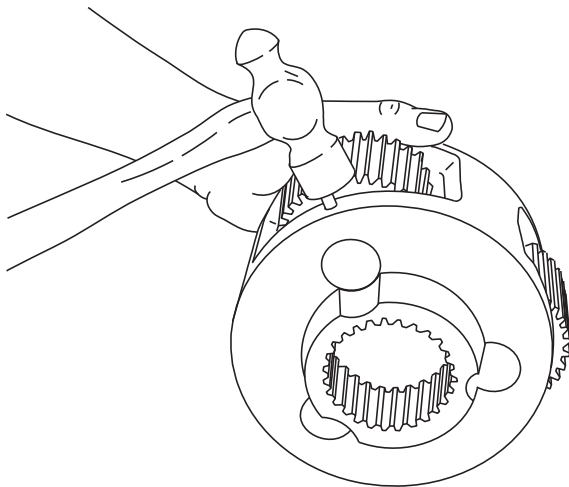

3. Carefully align the pin hole in the carrier with the hole in the planet gear shaft and drive the roll pin into place. Always use NEW roll pins. When properly positioned, 50% of the roll pin will engage the planet gear shaft and 50% will remain in the planet carrier.

PRIMARY PLANET CARRIER

1. To service the primary planet carrier, the steps are the same as for the output carrier except there is only one bearing for each gear and no bearing spacer.

HOIST ASSEMBLY

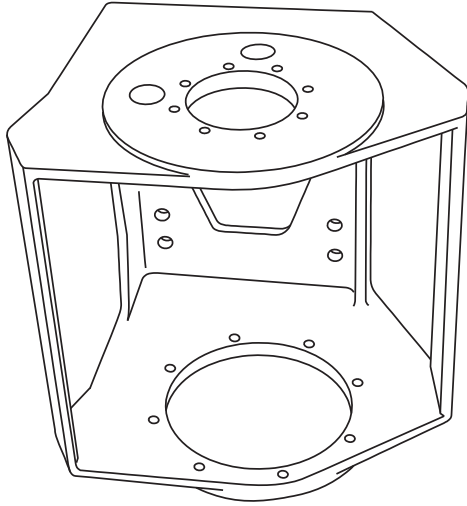

1. Place hoist base on side with bearing support end up.
2. Install a new bearing in the drum if replacement is necessary. Apply a non-hardening sealant on the outside diameter of the new seal. Install the spring side of the seal next to the bearing, then press into the drum, using a flat plate to avoid distortion. Be sure drain plug is installed securely.

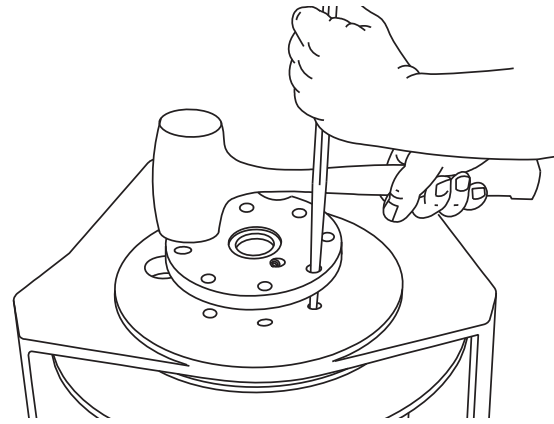
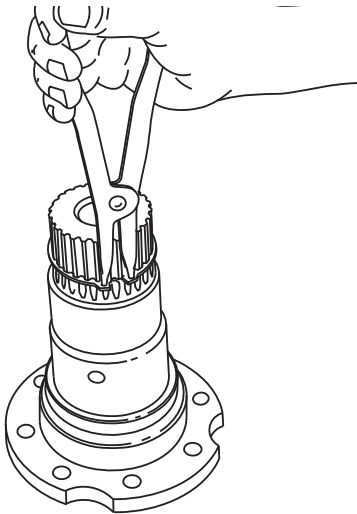

3. Center the drum in the opening of the base. Lubricate the bearing support with petroleum jelly or gear oil and install in base and drum.

⚠ CAUTION ⚠

Be sure the vent plug is located above the horizontal centerline for the intended application. Oil leakage may occur if vent is positioned incorrectly.

4. Tighten the bearing support capscrews to the recommended torque.

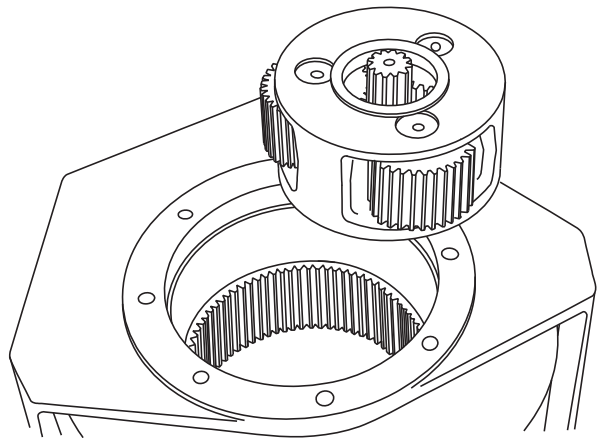

5. Stand hoist on bearing support end. Install the output sun gear and thrust washer into output planet carrier.

⚠ CAUTION ⚠

Make certain the snap ring is installed on the bearing support. This snap ring will keep the output planet carrier correctly positioned in the hoist. Gear train damage may occur if this snap ring is omitted.

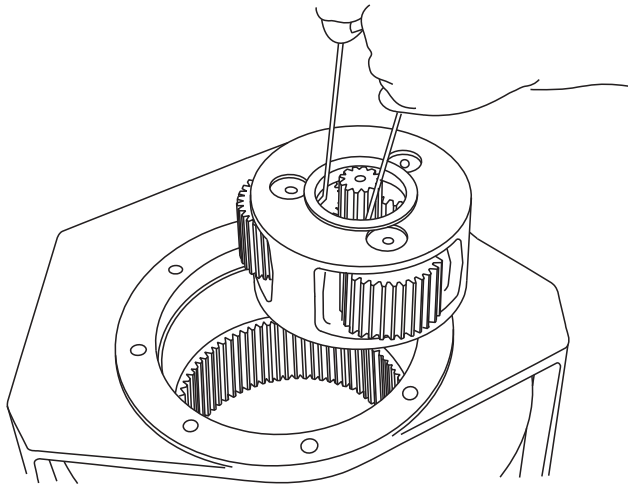

6. Install the output planet carrier into the drum while meshing the planet gears with the ring gear and the planet housing with the bearing support.
7. Install the primary sun gear and thrust washer into the primary planet carrier.

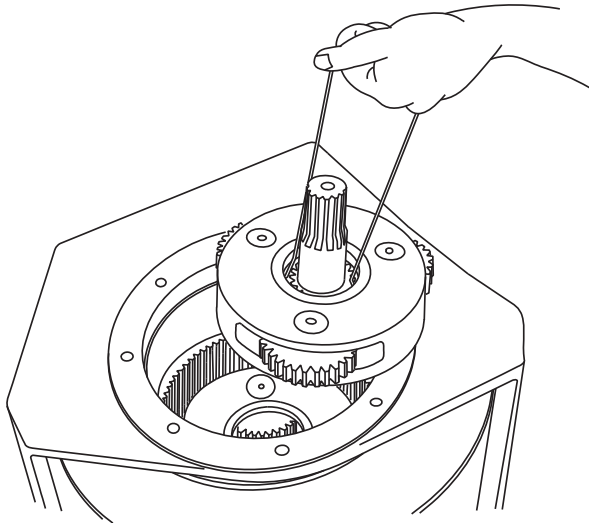

8. Install the primary planet carrier, meshing the planet gears with the ring gear and the planet housing with the output sun gear.

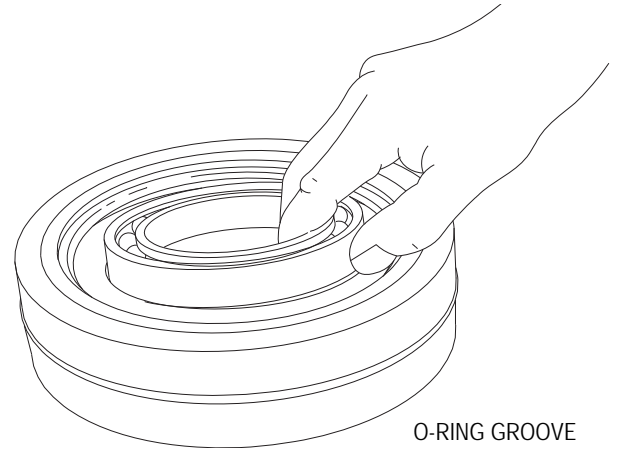

O-RING GROOVE

9. Install a new bearing in the drum closure as required. Use sealant on the outside surface of the oil seal. Install with spring side of the seal toward bearing, using a flat plate to avoid distortion.

Install a new O-ring in the groove on the O.D. of the drum closure.

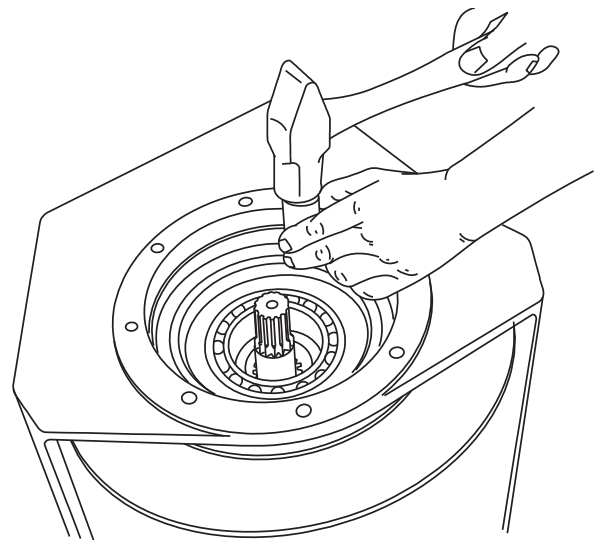

10. Lubricate the O-ring and drum opening with petroleum jelly or gear oil and install the drum closure into the drum.
11. Lubricate the pilot, oil seal and bearing surfaces of the brake cylinder and carefully install brake cylinder into base and drum. Locate the brake release port toward the lower rear corner of the base. Tighten brake cylinder capscrews to recommended torque.

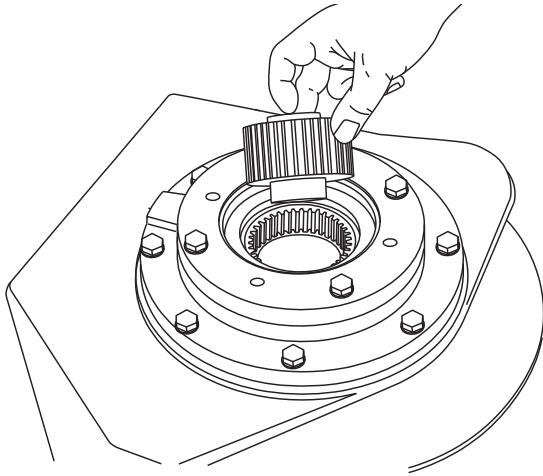

12. Install the brake clutch assembly.

NOTE: The snap ring installed in the bore of the inner race is not centered in the splines. The long spline engagement end **MUST** always install toward the motor to permit proper positioning of the brake clutch within the internal brake assembly.

When installed correctly, the inner race should turn freely in the opposite direction the drum turns to pull wire rope in. An easy way to check the rotation is to hold the outer race in one hand, and rotate the inner race from the motor side.

If the clutch free wheels in the wrong direction, disassemble the clutch and reverse the inner race. Refer to "Brake Clutch Service" for additional information.

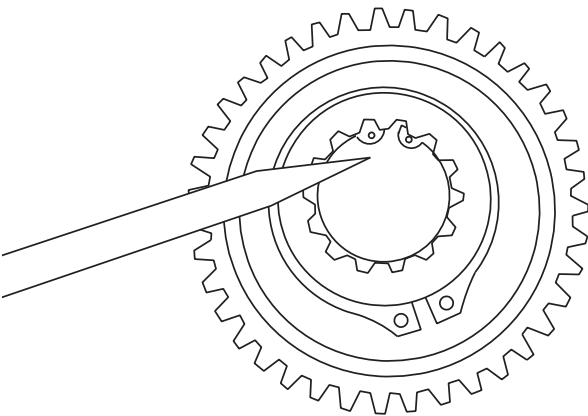

13. If the brake discs are misaligned, preventing the installation of the clutch, then with a hand pump, apply 750-1000 psi to the brake release port. The brake discs will move freely with the brake released

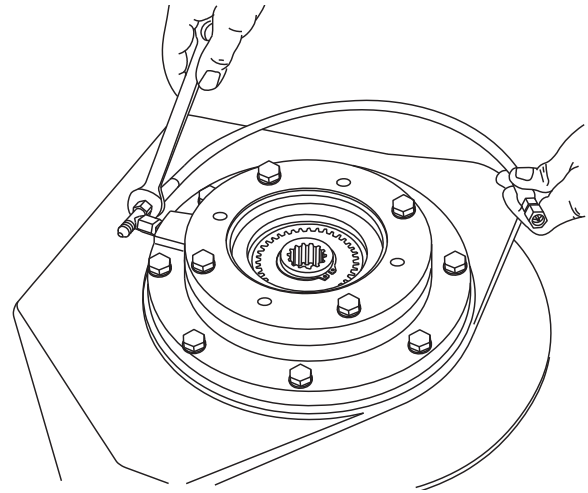

14. Install the hoses and fittings to the brake cylinder release port.

15. Install a new O-ring on the motor pilot then lubricate with petroleum jelly or gear oil.

16. Engage the motor shaft with the brake clutch inner race and lower motor into place. Tighten capscrews to recommended torque.

17. Install the hoses that connect the manifold and brake valve to the brake cylinder.

18. After the hoist assembly is complete, check all capscrews and fittings to make certain they have been tightened correctly.

Refill the hoist with the recommended oil listed under "Preventive Maintenance", and install the oil level plug.

▲ WARNING ▲

Be certain the snap ring is seated in the groove in the splined bore of the inner race. This snap ring will keep the brake clutch assembly correctly positioned in the center of the friction brake pack. Binding of the brake or brake failure may occur if this snap ring is omitted.

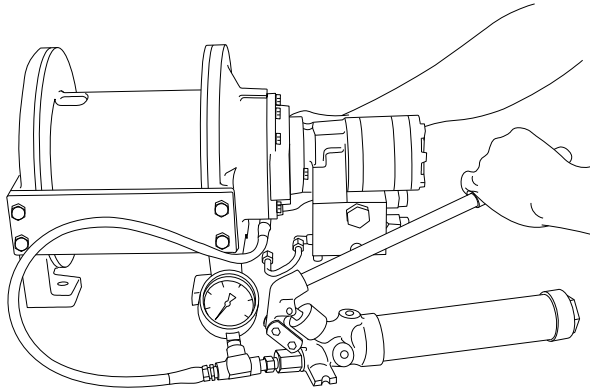

19. Install a hand pump with an accurate 0-2,000 psi (0-13,800 kPa) gauge and shut-off valve to the brake release port. Apply 1,000 psi (6,900 kPa) to the brake and close the shut-off valve. Let the brake stand for five (5) minutes. If there is any loss of pressure, the brake pack should be disassembled for inspection of the sealing surfaces and the brake piston. Release the pressure, remove the hand pump and install the brake release tube (43) between the brake valve block (39) and the brake release port.

REVERSING DIRECTION OF DRUM ROTATION

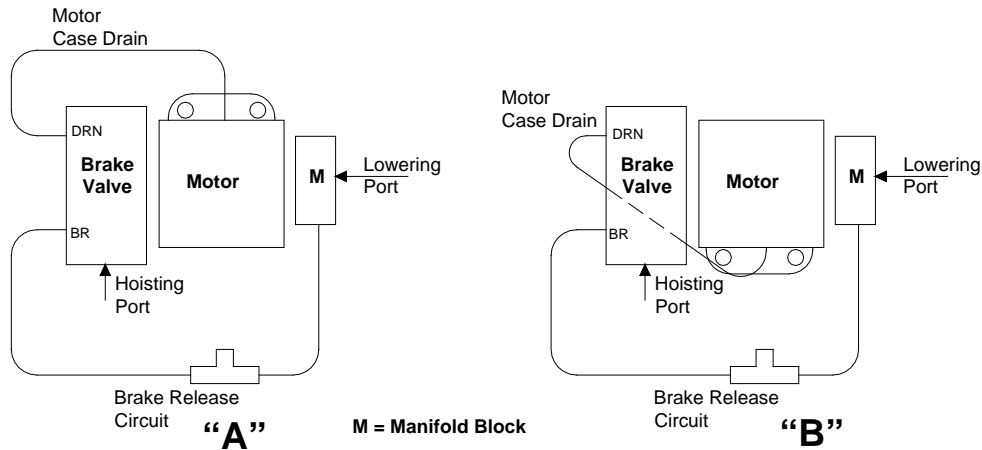

NOTE: Only BG6A and BG6B hoists equipped with gear motors and Braden cast brake valves are capable of being configured for opposite, or underwound drum rotation.

In order to change the direction of rotation, 2 things must be changed on the winch. First, the motor must be made to rotate in the opposite direction. This is done by exchanging positions of the brake valve and manifold block on the motor. Secondly, the brake clutch assembly must be made effective for the opposite direction of rotation. This is done by reversing the inner race of the brake clutch assembly.

Figures "A" and "B" above show typical BG6 gear motor installations. Note that the only difference between the two drawings is the motor is rotated 180° (the "belly" of the motor moves to the opposite side). If the motor shaft rotates clockwise in figure 'A' when the hoisting port is pressurized, it will rotate counterclockwise in figure "B".

1. Remove the four capscrews securing the brake valve to the motor. Remove the four capscrews securing the manifold block to the motor. Disconnect the motor case drain hose at the motor. **NOTE:** Some installations have the brake release hose connected directly to the motor, instead of to the manifold block. In this case, disconnect the brake release hose at the motor port. Stand winch up on drum support with the motor end up and secure in this position.

2. Before removing the motor, it is a good idea to note or mark the position of the motor in relation to the winch, since it will be rotated 180° when reinstalled. Remove the capscrews securing the motor to the winch and carefully remove the motor.

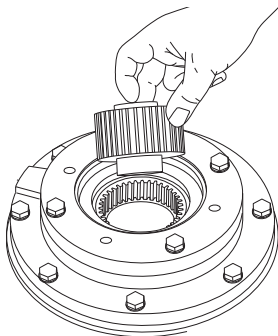

3. Remove the brake clutch assembly from the motor support.

4. Remove the snap ring and sprag bushing retainer from one end only of the brake clutch assembly.

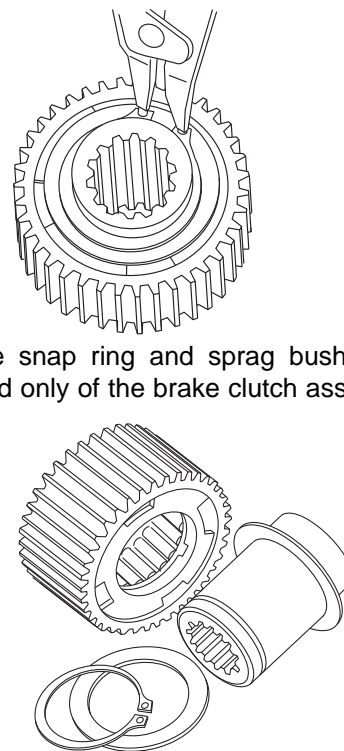

5. Pull the inner race out. Examine the race for scoring, wear or indentations caused by the sprag cams. If the inner race is not completely smooth, the assembly should be replaced.

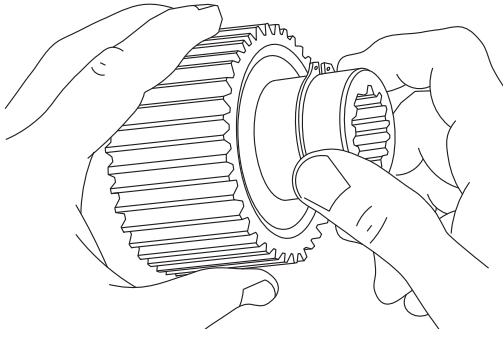

- Turn the sprag assembly around and slide the inner race (with 1 snap ring and bushing retainer) through the bushings and sprag clutch (the race will have to be rotated in the free-wheeling direction to start it through the sprag clutch). Install the remaining bushing retainer and snap ring. Make certain the snap ring is properly seated in the groove.

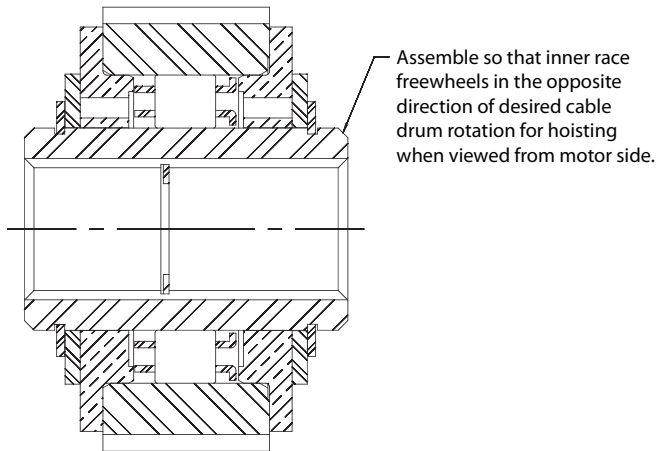

- Before installing the brake clutch, be sure the inner race turns free in the opposite direction the drum will turn to haul-in wire rope. An easy way to check the rotation is to hold the outer race in one hand and rotate the inner race from the motor side. Install the brake clutch.

NOTE: The snap ring installed in the bore of the inner race is not centered in the splines. The long spline engagement end **MUST** always install toward the motor to permit proper positioning of the brake clutch within the internal brake assembly.

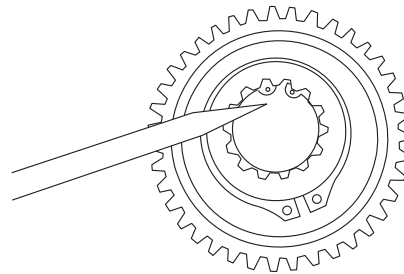

⚠ WARNING ⚠

Be certain the snap ring is seated in the groove in the splined bore of the inner race. This snap ring will keep the brake clutch assembly correctly positioned in the center of the friction brake pack. Binding of the brake or brake failure may occur if this snap ring is omitted.

- Install a new O-ring on the motor pilot. Rotate the motor 180° from its original position and install it onto the winch. Install and tighten motor capscrews to recommended torque.
- Install new O-rings in the brake valve and manifold block. Attach the brake valve and manifold block to the motor using the original capscrews and tighten to recommended torque.
- Connect the motor case drain hose to the motor case drain port.
- If your winch had the brake release hose connected directly to the motor, the original motor port must be plugged and the hose connected to the motor pressure port near the manifold block (lowering port).
- Operate the winch slowly in both directions and check for oil leaks and/or unusual sounds from the winch. The winch should operate smoothly in both directions. Refer to "WIRE AND BRAIDED ROPE INSTALLATION" and properly install rope onto the winch drum.
- Before returning the winch to full service, a light load should be lifted and held a few feet off the ground to be sure the static brake is functioning properly. The winch should also be able to slowly lower the load in a smooth and controlled manner. If the winch does not perform either of these functions, refer to "TROUBLESHOOTING" for additional information.

RECOMMEND FASTENER TORQUE

The general purpose torque shown in the chart applies to SAE Grade 5 bolts, studs and standard steel full, thick and high nuts.

Higher or lower torques for special applications will be specified such as the use of spanner nuts, nuts on shaft ends, jam nuts and where distortion of parts or gaskets is critical.

Lubricated Torque values based on use of SAE 30wt engine oil applied to threads and face of bolt or nut.

Avoid using thread lubricants as the applied torque may vary by 10-40% depending upon product used.

RECOMMENDED FASTENER TORQUE

Bolt Dia. Inches	Thds Per Inch	Torque (LB-FT)			
		Grade 5		Grade 8	
		Dry	Lubed	Dry	Lubed
1/4	20 28	8	6	12	9
5/16	18 24	17	13	24	18
3/8	16 24	31	23	45	35
7/16	14 20	50	35	70	50
1/2	13 20	75	55	110	80
9/16	12 18	110	80	150	110
5/8	11 18	150	115	210	160

Bolt Dia. Inches	Thds Per Inch	Torque (LB-FT)			
		Grade 5		Grade 8	
		Dry	Lubed	Dry	Lubed
3/4	10 16	265	200	380	280
7/8	9 14	420	325	600	450
1	8 14	640	485	910	680
1 1/8	7 12	790	590	1290	970
1 1/4	7 12	1120	835	1820	1360
1 3/8	6 12	1460	1095	2385	1790
1 1/2	6 12	1940	1460	3160	2370

METRIC CONVERSION TABLE

MULTIPLY: BY: TO GET: MULTIPLY: BY: TO GET:

LINEAR					
inches (in.)	X 25.4	= millimeters (mm)	millimeters (mm)	X 0.3937	= inches (in.)
feet (ft.)	X 0.3048	= meters (m)	meters (m)	X 3.281	= feet (ft.)
miles (mi.)	X 1.6093	= kilometers (km)	kilometers (km)	X 0.6214	= miles (mi.)
AREA					
inches ² (sq.in.)	X 645.15	= millimeters ² (mm ²)	millimeters ² (mm ²)	X 0.000155	= inches ² (sq.in.)
feet ² (sq.ft.)	X 0.0929	= meters ² (m ²)	meters ² (m ²)	X 10.764	= feet ² (sq.ft.)
VOLUME					
inches ³ (cu.in.)	X 0.01639	= liters (l)	liters (l)	X 61.024	= inches ³ (cu.in.)
quarts (qts.)	X 0.94635	= liters (l)	liters (l)	X 1.0567	= quarts (qts.)
gallons (gal.)	X 3.7854	= liters (l)	liters (l)	X 0.2642	= gallon (gal.)
inches ³ (cu.in.)	X 16.39	= centimeters ³ (cc)	centimeters ³ (cc)	X 0.06102	= inches ³ (cu.in.)
feet ³ (cu.ft.)	X 28.317	= liters (l)	liters (l)	X 0.03531	= feet ³ (cu.ft.)
feet ³ (cu.ft.)	X 0.02832	= meters ³ (m ³)	meters ³ (m ³)	X 35.315	= feet ³ (cu.ft.)
fluid ounce (fl.oz.)	X 29.57	= milliliters (ml)	milliliters (ml)	X 0.03381	= fluid ounce (fl.oz.)
MASS					
ounces (oz.)	X 28.35	= grams (g)	grams (g)	X 0.03527	= ounces (oz.)
pounds (lbs.)	X 0.4536	= kilograms (kg)	kilograms (kg)	X 2.2046	= pounds (lbs.)
tons (2000 lbs.)	X 907.18	= kilograms (kg)	kilograms (kg)	X 0.001102	= tons (2000 lbs.)
tons (2000 lbs.)	X 0.90718	= metric tons (t)	metric tons (t)	X 1.1023	= tons (2000 lbs.)
tons (long) (2240 lbs.)	X 1013.05	= kilograms (kg)	kilograms (kg)	X 0.000984	= tons (long) (2240 lbs.)
PRESSURE					
inches Hg (60°F)	X 3600	= kilopascals (kPa)	kilopascals (kPa)	X 0.2961	= inches Hg (60°F)
pounds/sq.in. (PSI)	X 6.895	= kilopascals (kPa)	kilopascals (kPa)	X 0.145	= pounds/sq.in. (PSI)
pounds/sq.in. (PSI)	X 0.0703	= kilograms/sq.cm. (kg/cm ²)	kilograms/sq.cm. (kg/cm ²)	X 14.22	= pounds/sq.in. (PSI)
pounds/sq.in. (PSI)	X 0.069	= bars	bars	X 14.5	= pounds/sq.in. (PSI)
inches H ₂ O (60°F)	X 0.2488	= kilopascals (kPa)	kilopascals (kPa)	X 4.0193	= inches H ₂ O (60°F)
bars	X 100	= kilopascals (kPa)	kilopascals (kPa)	X 0.01	= bars
POWER					
horsepower (hp)	X 0.746	= kilowatts (kW)	kilowatts (kW)	X 1.34	= horsepower (hp)
ft.-lbs./min.	X 0.0226	= watts (W)	watts (W)	X 44.25	= ft.-lbs./min.
TORQUE					
pound-inches (in.-lbs.)	X 0.11298	= newton-meters (N-m)	newton-meters (N-m)	X 8.851	= pound-inches (in.-lbs.)
pound-feet (ft.-lbs.)	X 1.3558	= newton-meters (N-m)	newton-meters (N-m)	X 0.7376	= pound-feet (ft.-lbs.)
pound-feet (ft.-lbs.)	X .1383	= kilograms/meter (kg-m)	kilogram/meter (kg-m)	X 7.233	= pound-feet (ft.-lbs.)
VELOCITY					
miles/hour (m/h)	X 0.11298	= kilometers/hour (km/hr)	kilometers/hour (km/hr)	X 0.6214	= miles/hour (m/h)
feet/second (ft./sec.)	X 0.3048	= meter/second (m/s)	meters/second (m/s)	X 3.281	= feet/second (ft./sec.)
feet/minute (ft./min.)	X 0.3048	= meter/minute (m/min)	meters/minute (m/min)	X 3.281	= feet/minute (ft./min.)
TEMPERATURE					
°Celsius = 0.556 (°F - 32)			°Fahrenheit = (1.8 X °C) + 32		
COMMON METRIC PREFIXES					
mega	(M)	= 1,000,000 or 10 ⁶	deci	(d)	= 0.1 or 10 ⁻¹
kilo	(k)	= 1,000 or 10 ³	centi	(c)	= 0.01 or 10 ⁻²
hecto	(h)	= 100 or 10 ²	milli	(m)	= 0.001 or 10 ⁻³
deka	(da)	= 10 or 10 ¹	micro	(µ)	= 0.000.001 or 10 ⁻⁶