

INSTALLATION MANUAL AND PARTS LIST

Installation Parts Kit to Install H140/PA140 Winch on Winch-ready Caterpillar D8T Dozer

- **Installation Parts Kit – PACCAR Part number 65248, Caterpillar Part number 504-7377**
- **Winch (sold separately) – PACCAR Part number 09091, 09098, or equivalent. Caterpillar Part number 431-9575 or equivalent.**
- **D8T Tractor factory-equipped or field-retrofitted with Caterpillar “Hydraulics, Winch” and “Controls, Winch”**

Visit our Web site at www.paccarwinch.com for the most comprehensive collection of winch, hoist, and drive information on the Internet. Most publications and specification sheets are available for downloading.

Table of Contents

Foreword	2
General Safety Recommendations	3
Mounting Group Metric Diagram and Components	4
Mounting Group Metric Installation	5
Winch Motor Lines Group Diagram and Components	6
Winch Motor Lines Group Installation	7
Metric Conversion Table	8

FOREWORD

Read this entire publication and retain it for future reference.

For inquiries regarding your CARCO winch or this publication, please contact the CARCO Service Department at 918-251-8511, Monday through Friday, 8:00 a.m. to 4:30 p.m. (CST).

This parts list and service manual has been prepared to provide maintenance information for the winch motor lines group and the mounting group metric, specific to CAT H110/D8T Metric.

GENERAL SAFETY RECOMMENDATIONS

Safety for operators and ground personnel is of prime concern. Always take the necessary precautions to ensure the safety of others as well as yourself. To properly ensure safety, the prime mover and winch **MUST** be operated with care and concern by the operator for the equipment. The operator **MUST** also have a thorough knowledge of the machine's performance capabilities.

1. Read and understand **ALL** warning tag information, and become familiar with **ALL** controls **BEFORE** operating the winch.
2. **NEVER** attempt to clean, oil or perform maintenance on a machine with the engine or prime mover running, unless instructed to do so in this manual.
3. **NEVER** operate the winch controls unless you are properly positioned at the operator's station, you are sure **ALL** personnel are clear of the work area **AND** you are properly trained in the operation of the winch.
4. Assure that personnel who are responsible for hand signals are clearly visible and that the signals to be used are thoroughly understood by all involved.
5. Ground personnel should stay in view of the operator and clear of the winch drum. **DO NOT** allow ground personnel near a winch line under tension. A safe distance of at least 1-1/2 times the length of the outstretched cable should be maintained.
6. On machines having hydraulically, mechanically and/or cable controlled equipment or attachments, ensure the equipment is blocked securely before servicing, adjusting or repairing the winch. **ALWAYS** apply the parking brakes before dismounting a vehicle.
7. Inspect the winch and rigging at the beginning of each work shift. Defects should be corrected immediately. **DO NOT** operate a defective winch.
8. Keep equipment in good operating condition. Perform scheduled service and adjustments as defined in the Preventive Maintenance section of this manual.
9. An equipment warm-up procedure is recommended for all start-ups, and is essential at ambient temperatures below +40°F (5°C). Refer to the "Warm-up Procedure" listed in the Preventive Maintenance section of this manual.
10. Freespool clutches on recovery winches may disengage and drop or lose control of a load if they are not fully engaged at the beginning of a lift or pull.
11. The winches described in this manual are neither designed nor intended for use or application to equipment used in the lifting or moving of persons.
12. **DO NOT** exceed the maximum pressure, kPa (PSI), or flow, LPM (GPM), stated in the winch specifications.
13. Operate the winch at line speeds to match the job conditions.
14. Protective gloves should be worn when handling wire rope.
15. **NEVER** attempt to handle wire rope when the hook end is not free. Keep all parts of body and clothing clear of cable rollers, cable entry area of fairleads and winch cable drum.
16. When winding wire rope on the cable drum, **NEVER** attempt to maintain tension by allowing the wire rope to slip through hands. **ALWAYS** use the hand-over-hand technique.
17. **NEVER** use wire rope with broken strands. Replace damaged wire rope.
18. **DO NOT** weld on any part of the winch.
19. Use the recommended hydraulic oil and gear lubricant. Keep the hydraulic system clean and free of contamination at all times.
20. The cable anchor or set screw is **NOT** intended to support full rated load. **ALWAYS** maintain a minimum of five wraps on the drum. It is recommended the last five wraps of wire rope be painted bright red to serve as a visual reminder. **DO NOT** use knots to secure or attach the wire rope to the drum or hook.
21. Install guarding to prevent personnel from getting any part of body or clothing caught at a point where the cable is wrapped onto the drum or drawn through guide rollers or other pinch points.
22. Install switches or valves that will shut off power to the winch, in locations where they can be reached by anyone entangled in the wire rope before being drawn into the winch drum or other pinch point.
23. Deadman controls, which automatically shut off power to the winch whenever the operator leaves his station, should be installed whenever possible.
24. **NEVER** allow anyone to stand or position any part of the body under a suspended load.
25. Avoid sudden shock loads, or attempting to jerk a load free. This type of operation may cause heavy loads, in excess of rated capacity, which may result in a failure of the wire rope and/or the winch.

MOUNTING GROUP METRIC COMPONENTS

Part number 63414

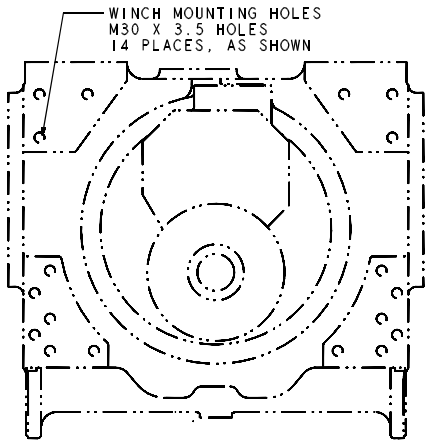
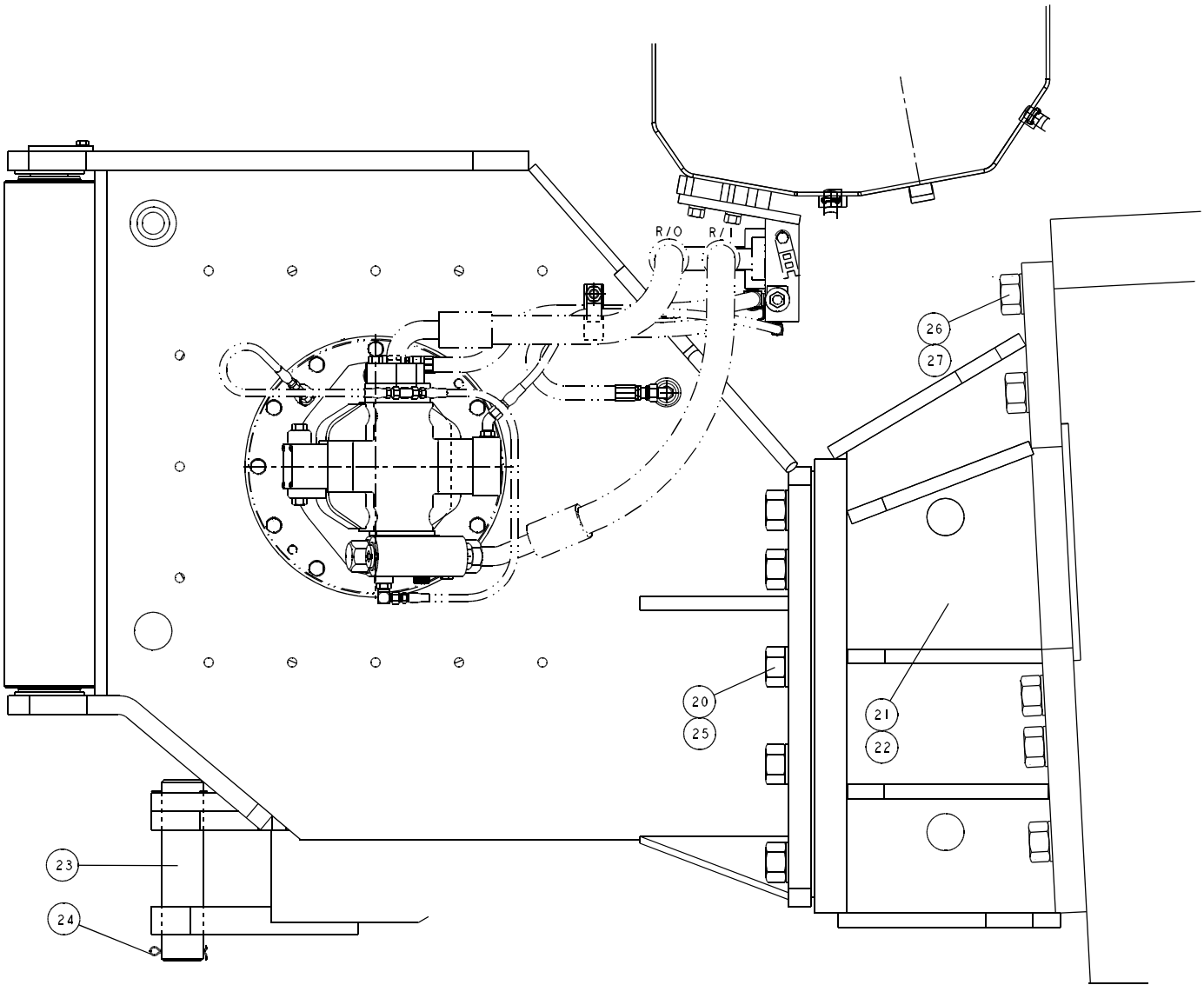

TRACTOR REAR FACE

ITEM NO.	PACCAR WINCH PART NO.	DESCRIPTION	CATER-PILLAR PART NO.	QTY.
20	101872	Capscrew	7X-0427	10
21	105597	Bracket, lefthand	152-8372	1
22	105598	Bracket, righthand	152-8371	1
23	103102	Hitch pin	197-7837	1
24	70148	16288-1248 Cotter pin	3B-5320	2
25	101206	Washer C0125Z hard	7X-0533	10
26	104193	Capscrew, metric	7X-2580	14
27	104194	Washer, M30 hard Z	9X-8258	14

MOUNTING GROUP METRIC INSTALLATION

Part number 63414

Mounting Group

1. If present, remove Caterpillar factory plugs from indicated holes in rear of tractor frame (14 holes). Leave factory plugs in holes that are not used to mount winch.
2. Clean all mating surfaces on winch mounting brackets (Items 21 and 22), winch, and rear face of tractor frame.
3. Clean all threaded holes in winch mounting brackets (10 holes) and rear face of tractor frame (14 holes). Ensure that all threads are in good condition.
4. Install winch mounting brackets (Items 21 and 22) to rear face of tractor frame as shown using M30 capscrews and washers (Items 26 and 27). Use of either medium-strength threadlocking compound or antiseize compound on capscrew threads is permissible but not required.

CAUTION

Each mounting bracket weighs approximately 264 pounds (120 kg). Make certain lifting equipment has adequate capacity. Use appropriate lifting equipment and techniques to protect against property damage, injury, or death.

5. Tighten M30 capscrews (Item 26) to 1180 ft-lb (1600 n-m).
6. Remove motor cover from winch. Retain motor cover and all fasteners for reinstallation after completing all hydraulic connections.

CAUTION

Motor cover weighs approximately 95 pounds (43 kg). Make certain lifting equipment has adequate capacity. Use appropriate lifting equipment and techniques to protect against property damage, injury, or death.

7. Lift winch and install to winch mounting brackets as shown using 1-1/4-inch capscrews and washers (Items 20 and 25). Use of either medium-strength threadlocking compound or antiseize compound on capscrew threads is permissible but not required.

WARNING

The winch assembly weighs approximately 4,025 pounds (1,825 kg) without oil, cable, and tractor adapters. Ensure lifting equipment has adequate capacity. Attempting to lift the winch with inadequate equipment may result in property damage, injury, or death.

8. Tighten 1-1/4-inch capscrews (Item 20) to 1320 ft-lb (1800 n-m).
9. Install hitch pin (Item 23) in winch drawbar as shown. Secure hitch pin using cotter pins (Item 24).
10. Check winch gear oil level as outlined in winch service manual. Top-off winch gear oil if needed. Refer to winch service manual for oil recommendations.

WINCH MOTOR LINES GROUP COMPONENTS

Part number 63673

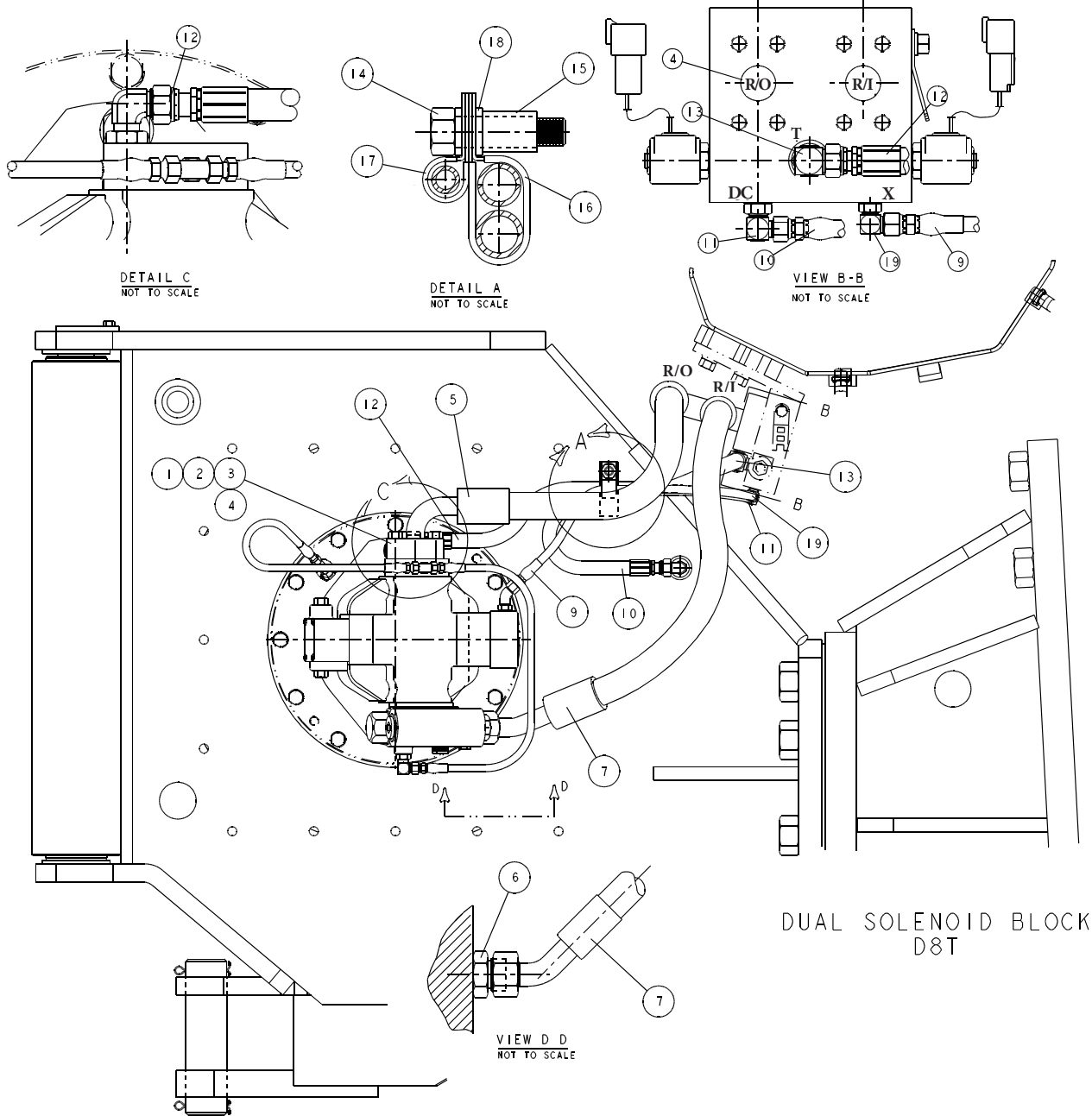

ITEM NO.	PACCAR PART NO.	DESCRIPTION	CAT. PART NO.	QTY
1	101277	Split flange half (CAT)	1P-5766	2
2	104319	Capscrew	7X-0313	4
3	101432	Washer, hard	8T-5360	4
4	101278	D-ring, split flange (CAT)	1P-3703	3
5	105454	Hose -16 XT-5 X 32.0	240-8865	1
6	40115	Adapter	148-8317	1
7	105453	Hose -16 XT-5 X 34.5	240-8862	1
9	101831	Hose -4 X 26.0	8W-6688	1
10	101261	Hose assembly -6 X 36.0	152-8360	1
11	40107	Elbow	148-8378	1

ITEM NO.	PACCAR PART NO.	DESCRIPTION	CAT. PART NO.	QTY
12	101830	Hose -8 X 29.0	163-3189	1
13	101282	Elbow, 90-degree	148-8364	1
14	102347	Capscrew	7X-0326	1
15	102346	Spacer	1F-1560	1
16	PA6D7573	Clip, double	6D-7573	1
17	27501	Hose clamp	1S-6420	1
18	100859	Washer	8T-4223	2
19	27430	Adapter, 90-degree elbow ORS/ORB	148-8369	1

WINCH MOTOR LINES GROUP INSTALLATION

Part number 63673

Lines Group

NOTE: To minimize loss of hydraulic fluid during installation of the winch hydraulic connections, it may be desirable to drain the tractor implement hydraulic system or at least draw a sustained vacuum on the tractor implement hydraulic tank.

1. Remove shipping plugs from T, DC, and X ports of tractor manifold as shown. Install elbows (Items 11, 13, and 19) as shown. Leave elbow jam nuts finger tight to facilitate hose routing adjustment later.
2. Remove shipping caps from motor case drain, drum clutch, and low-lock elbows on winch.
3. Install small hydraulic hoses (Items 9, 10, and 12) between winch and tractor manifold as shown. Leave hose end nuts finger tight to facilitate hose routing adjustment later.
4. Secure center of small hoses with clip assembly as shown in Detail A (Items 14, 15, 16, 17, and 18).
5. Adjust elbow orientation and routing of small hoses to achieve smooth bend radii, eliminate twisting, and minimize chafing.
6. Tighten elbow jam nuts and hose end nuts. Always hold the elbow body steady with a wrench when tightening the jam nut. Always hold the hose end crimp fitting steady with a wrench when tightening the hose end nut to prevent twisting the hose.
7. Loosen left split-flange half, remove right split-flange half, and remove shipping plug from reel-in (R/I) port in tractor manifold as shown. Retain split-flange half and fasteners for reinstallation later.
8. Remove plastic shipping plug from reel-in port in winch brake valve (located at the bottom of the winch motor). Take care to remove the *plastic* shipping plug only. DO NOT disturb the similar-sized *steel* plug located adjacent to the plastic plug.
9. Install adapter fitting (Item 6) in brake valve port as shown in View DD. Tighten adapter fitting.
10. Install D-ring (Item 4) in flange end of hose (Item 7). Install flange end of hose (Item 7) to R/I port in tractor manifold. Secure with split-flange half and fasteners retained from Step 7. Install face-seal end of hose (Item 7) to adapter fitting (Item 6) as shown. Leave split-flange fasteners and hose end nut finger tight to facilitate hose routing adjustment later.
11. Adjust routing of hose (Item 7) to achieve smooth bend radii, prevent chafing, and eliminate twisting.
12. Tighten end nut of hose (Item 7). Hold the hose end crimp fitting steady with a wrench or other appropriate tool when tightening the hose end nut to prevent twisting the hose. Tighten split-flange fasteners.
13. Loosen right split-flange half, remove left split-flange half, and remove shipping plug from reel-out (R/O) port in tractor manifold. Retain split-flange half and fasteners for reinstallation later.
14. Remove shipping cover and shipping cover gasket from top work port in winch motor. Keep spacer manifold in place.
15. Install D-rings (Item 4) in both ends of hose (Item 5). Install long-drop end of hose (Item 5) to R/O port in tractor manifold as shown. Secure with split-flange half and fasteners retained from Step 13. Install short-drop end of hose (Item 5) to spacer manifold on top work port of winch motor as shown. Secure with split-flange halves, (long) capscrews, and washers (Items 1, 2, and 3). Leave split-flange fasteners finger tight to facilitate hose routing adjustment later.
16. Adjust routing of hose (Item 5) to achieve smooth bend radii, prevent chafing, and eliminate twisting.
17. Tighten split-flange fasteners.
18. Refill tractor hydraulic system or remove vacuum from tank if either step was performed previously.
19. Check for leaks.
20. Start tractor and test reel-in, reel-out, and low-lock functions of winch as outlined in winch service manual.
21. Recheck for leaks.
22. Reinstall winch motor cover.

METRIC CONVERSION TABLE

English to Metric

Metric to English

LINEAR

inches (in.)	X 25.4	= millimeters (mm)	millimeters (mm)	X 0.03937	= inches (in.)
feet (ft.)	X 0.3048	= meters (m)	meters (m)	X 3.281	= feet (ft.)
miles (mi.)	X 1.6093	= kilometers (km)	kilometers (km)	X 0.6214	= miles (mi.)

AREA

inches ² (sq.in.)	X 645.15	= millimeters ² (mm ²)	millimeters ² (mm ²)	X 0.000155	= inches ² (sq.in.)
feet ² (sq.ft.)	X 0.0929	= meters ² (m ²)	meters ² (m ²)	X 10.764	= feet ² (sq.ft.)

VOLUME

inches ³ (cu.in.)	X 0.01639	= liters (l)	liters (l)	X 61.024	= inches ³ (cu.in.)
quarts (qts.)	X 0.94635	= liters (l)	liters (l)	X 1.0567	= quarts (qts.)
gallons (gal.)	X 3.7854	= liters (l)	liters (l)	X 0.2642	= gallon (gal.)
inches ³ (cu.in.)	X 16.39	= centimeters ³ (cc)	centimeters ³ (cc)	X 0.06102	= inches ³ (cu.in.)
feet ³ (cu.ft.)	X 28.317	= liters (l)	liters (l)	X 0.03531	= feet ³ (cu.ft.)
feet ³ (cu.ft.)	X 0.02832	= meters ³ (m ³)	meters ³ (m ³)	X 35.315	= feet ³ (cu.ft.)
fluid ounce (fl.oz.)	X 29.57	= milliliters (ml)	milliliters (ml)	X 0.03381	= fluid ounce (fl.oz.)

MASS

ounces (oz.)	X 28.35	= grams (g)	grams (g)	X 0.03527	= ounces (oz.)
pounds (lbs.)	X 0.4536	= kilograms (kg)	kilograms (kg)	X 2.2046	= pounds (lbs.)
tons (2000 lbs.)	X 907.18	= kilograms (kg)	kilograms (kg)	X 0.001102	= tons (2000 lbs.)
tons (2000 lbs.)	X 0.90718	= metric tons (t)	metric tons (t)	X 1.1023	= tons (2000 lbs.)
tons (long) (2240 lbs.)	X 1013.05	= kilograms (kg)	kilograms (kg)	X 0.000984	= tons (long) (2240 lbs.)

PRESSURE

inches Hg (60°F)	X 3600	= kilopascals (kPa)	kilopascals (kPa)	X 0.2961	= inches Hg (60°F)
pounds/sq.in. (PSI)	X 6.895	= kilopascals (kPa)	kilopascals (kPa)	X 0.145	= pounds/sq.in. (PSI)
pounds/sq.in. (PSI)	X 0.0703	= kilograms/sq.cm. (kg/cm ²)	kilograms/sq.cm. (kg/cm ²)	X 14.22	= pounds/sq.in. (PSI)
pounds/sq.in. (PSI)	X 0.069	= bars	bars	X 14.5	= pounds/sq.in. (PSI)
inches H ₂ O (60°F)	X 0.2488	= kilopascals (kPa)	kilopascals (kPa)	X 4.0193	= inches H ₂ O (60°F)
bars	X 100	= kilopascals (kPa)	kilopascals (kPa)	X 0.01	= bars

POWER

horsepower (hp)	X 0.746	= kilowatts (kW)	kilowatts (kW)	X 1.34	= horsepower (hp)
ft.-lbs./min.	X 0.0226	= watts (W)	watts (W)	X 44.25	= ft.-lbs./min.

TORQUE

pound-inches (in.-lbs.)	X 0.11298	= newton-meters (N-m)	newton-meters (N-m)	X 8.851	= pound-inches (in.-lbs.)
pound-feet (ft.-lbs.)	X 1.3558	= newton-meters (N-m)	newton-meters (N-m)	X 0.7376	= pound-feet (ft.-lbs.)
pound-feet (ft.-lbs.)	X .1383	= kilograms/meter (kg-m)	kilogram/meter (kg-m)	X 7.233	= pound-feet (ft.-lbs.)

VELOCITY

miles/hour (m/h)	X 0.11298	= kilometers/hour (km/hr)	kilometers/hour (km/hr)	X 0.6214	= miles/hour (m/h)
feet/second (ft./sec.)	X 0.3048	= meter/second (m/s)	meters/second (m/s)	X 3.281	= feet/second (ft./sec.)
feet/minute (ft./min.)	X 0.3048	= meter/minute (m/min)	meters/minute (m/min)	X 3.281	= feet/minute (ft./min.)

TEMPERATURE

$$^{\circ}\text{Celsius} = 0.556 (^{\circ}\text{F} - 32)$$

$$^{\circ}\text{Fahrenheit} = (1.8^{\circ}\text{C}) + 32$$

COMMON METRIC PREFIXES

mega	(M)	= 1,000,000 or 10 ⁶	deci	(d)	= 0.1 or 10 ⁻¹
kilo	(k)	= 1,000 or 10 ³	centi	(c)	= 0.01 or 10 ⁻²
hecto	(h)	= 100 or 10 ²	milli	(m)	= 0.001 or 10 ⁻³
deka	(da)	= 10 or 10 ¹	micro	(μ)	= 0.000.001 or 10 ⁻⁶