

Model Number
Serial Number

Most Braden winches have a raised pad on the housing which is embossed with the model and serial numbers of the winch. Since both of these numbers are extremely important in the shipment of the proper replacement parts, your order should always reference these numbers.

FOR BEST RESULTS, ALWAYS USE GENUINE BRADEN REPLACEMENT PARTS

TO ORDER PARTS:

1. List model and serial numbers of the winch.
2. Refer to exploded view and select the component(s) needed and list the item number(s).
3. Find item number(s) on material list, show part number, description and quantity required on your order.
4. Refer to parts price list and show price for each part or assembly.

RECOMMENDED WORM GEAR OIL

We have published the following specifications to help you determine which lubricant is best suited for your application. For simplicity, Braden has listed one readily available product in each temperature range which has been tested and found to meet our specifications. This is not to say that other lubricant brands would not perform equally as well.

If the following lubricant brands are not available in your area, make certain your lubricant vendor supplies you with oil that is equivalent to those products listed below.

PREVAILING AMBIENT TEMPERATURE

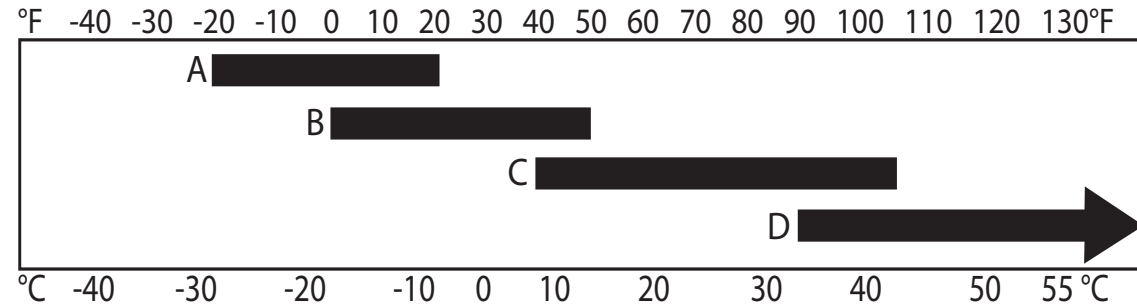

- A. AGMA Grade 3 EP; Mobilgear 600xp 100 or equivalent
- B. AGMA Grade 5 EP; Mobilgear 600xp 220 or equivalent
- C. AGMA Grade 7 EP; Mobilgear 600xp 460 or equivalent
- D. AGMA Grade 8 EP; Mobilgear 600xp 680 or equivalent

Brand recommendations in tier C climate range:

- MOBIL Mobilgear 600xp 460
- SHELL Omala 460
- CHEVRON Gear Compounds EP460
- TEXACO Meropa 460

MATERIAL LIST

BRADEN

MS50-20B
HS50P

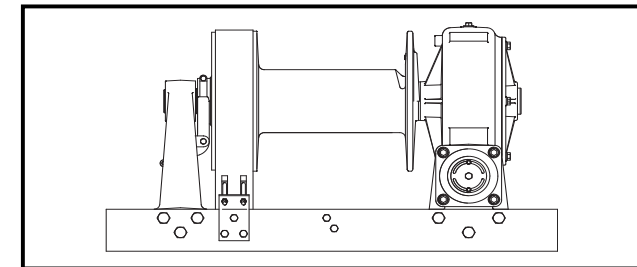

WRITE HOIST SERIAL NUMBER BELOW

--	--	--	--	--	--	--	--	--	--	--	--	--	--	--	--	--	--	--	--

First 2 numbers indicate year manufactured

⚠ WARNING ⚠

Do not use aftermarket additives in worm gear oil. some additives may contain substances which could cause glazing of brake discs or impede the firm locking action in the brake rotor assembly. Both symptoms could reduce load control which may result in property damage, personal injury or death.

BRADEN MS50-20B, HS50P-20B - COMPONENTS

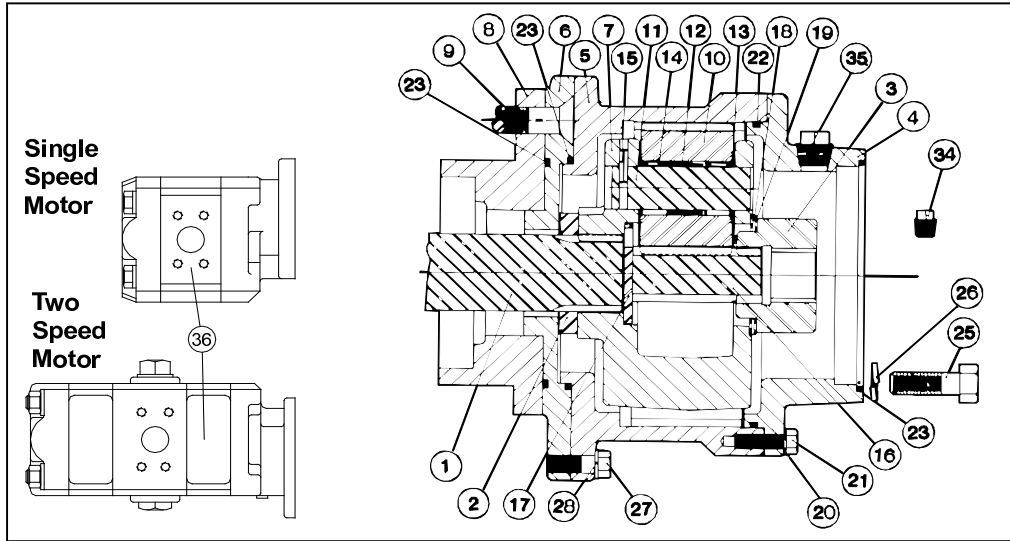

Gasket, Seal and Shim Kit - Part Number 62846	
6 ea.	Item 43 (0.030 in.)
1 ea.	Item 43 (0.015 in.)
1 ea.	Item 45
6 ea.	Item 33
1 ea.	Item 52
1 ea.	Item 41
1 ea.	Item 52
6 ea.	Item 80 (sealing washers)
2 ea.	Item 43A
2 ea.	Item 43B
1 ea.	Item 43C
1 ea.	Item 43D
2 ea.	Bearing Container O-Rings
2 ea.	Quad Rings

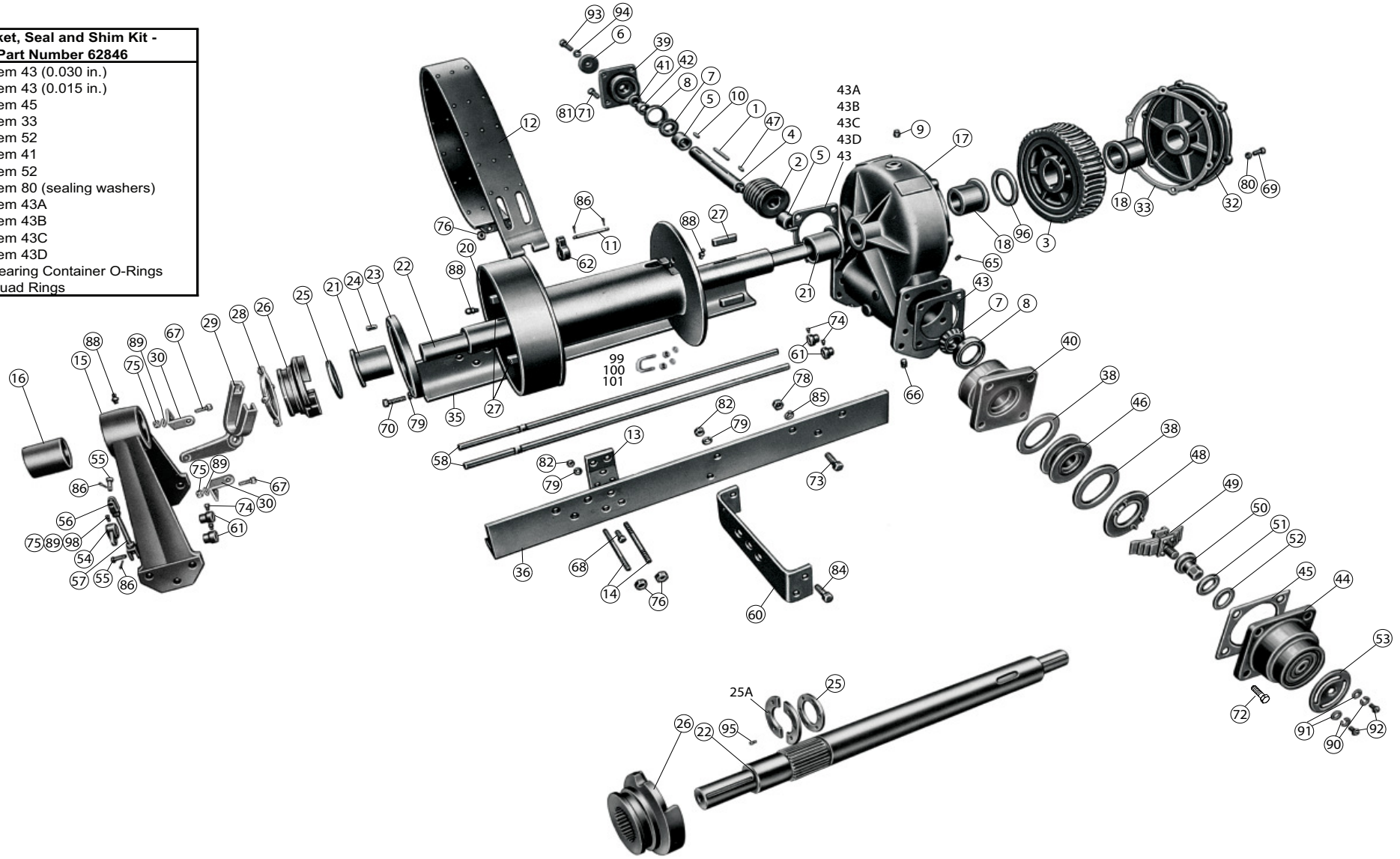

HS50P PLANETARY ADAPTER PARTS

ITEM	DESCRIPTION	PART	QTY
1	Worm Shaft	25357	1
2	Spacer	25354	1
3	Motor Coupling	25355	1
4	Motor Adapter	25307	1
5	Housing	25305	1
6	Adapter Plate	25327	1
7	Planet Carrier	25309	1
8	Bearing Container	11275	1
9	Capscrew (7/8 - 9 X 2 3/4 f-head socket)	25526	4
10	Planet Gear	26272	3
11	Planet Gear Shaft	24898	3
12	Bearing Spacer	24890	3
13	Thrust Bearing	24167	6
14	Roller Bearing	24175	6
15	Roll Pin	21049	3
16	Sun Gear	25359	1
17	Thrust Washer	25542	1
18	Needle Bearing	24950	1
19	Thrust Bearing Race	24912	2
20	Lockwasher (5/16)	11024	8
21	Capscrew (5/16 - 18 X 1 G8 Z)	11767	8
22	O-Ring	22721	1
23	O-Ring	10330	3
25	Capscrew (1/2 - 13 X 1 1/2 G8 Z)	104322	4
26	Lockwasher (1/2)	11026	4
27	Capscrew (3/8 - 16 X 1 1/4 G8 Z)	104132	8
28	Lockwasher (3/8)	27152	8
34	Pipe Plug	18009	1
35	Pipe Plug	23377	1
36	Hydraulic Motor - Single Speed	25274	1
	Hydraulic Motor - Two Speed	25337	1

MS50 BASIC MATERIAL LIST

ITEM	DESCRIPTION	PART NO.	QTY.
1	Worm Key	11256	1
	Worm, Right	NLA	1
2	Worm, Left	11264	1
3	Worm Gear, Right	NLA	1
	Worm Gear, Left	11266	1
4	Worm Shaft		
	S/N 7211319 and lower	11268	1
	S/N 7211320 and higher	22981	1
5*	Worm Spacer		
	S/N 9653312 and lower	40013	2
	S/N 9653313 and higher	100768	2
6	Shaft Washer	11651	1
7	Bearing Cone	12748	2
8	Bearing Cup	12749	2
9	Plug (1 in.)	22775	1
10	Key	10355	1
11	Brake Band Pin	12773	1
12	Brake Band Assembly	81591	1
13	Brake Link Bracket	12789	1
14	Brake Link	11652	2
15	Bearing Leg Assembly (w/bushing)	81039	1
16	Bearing Leg Bushing	12876	1
17	Worm Housing Assy. (with 1 of item 18)	82281	1

NLA - No Longer Available

ITEM	DESCRIPTION	PART NO.	QTY.
18***	Bushing, Worm Housing and Cover	100697	2
	Quad Ring (not shown)	100708	2
	(S/N 9653313 and higher)		
20	Cable Drum Assembly	81118	1
21	Cable Drum Bushing	100697	2
	Cable Drum Shaft		
	S/N 5705913 and lower	NLA	1
	S/N 5705914 to 6005645	NLA	1
	S/N 6005646 & higher (w/capstan lands)	NLA	1
	S/N 6005646 & higher (wo/capstan lands)	23524	1
23	Clutch Plate		
	S/N 6005645 and lower	11654	1
	S/N 6005646 and higher	11259	1
24	Clutch Plate Dowel	12769	2
25	Retaining Ring		
	S/N 5705913 and lower	11670	1
	S/N 5705914 and higher	11260	1
25A	Split Ring	11261	1
26	Clutch		
	S/N 5705913 and lower	NLA	1
	S/N 5705914 to 6005645	NLA	1
	S/N 6005646 and higher	11270	1
27	Key	11655	2 or 4

ITEM	DESCRIPTION	PART NO.	QTY.
28	Clutch Rider Assembly	61971	1
29	Shifter Fork	11673	1
30	Shifter Fork Bracket	11656	2
31	Pivot Pin (not shown)	11657	1
32	Housing Cover Assy (with 1 of item 18)	82280	1
33	Housing Cover Gasket	11262	1
35	Front Base Angle		
	S/N 6005645 and lower	NLA	1
	S/N 6005646 to 7211319	NLA	1
	S/N 7211320 and higher	22889	1
36	Rear Base Angle		
	S/N 6005645 and lower	NLA	1
	S/N 6005646 to 7211319	NLA	1
	S/N 7211320 and higher	22890	1
38	Friction Disc	29749	2
39	Bearing Container (with bushing item 42)	81297	1
40	Bearing Container	11275	1
	Bearing Container O-Rings	100707	2
	S/N 9653313 and higher		
41	Seal	11658	1
42	Bushing	23219	1
43**	Bearing Container Gasket (0.030 in.)	11660	A.R.
	Bearing Container Gasket (0.015 in.)	13847	A.R.
43A**	Bearing Container Shim (0.003 in.)	100693	A.R.
43B**	Bearing Container Shim (0.005 in.)	100694	A.R.
43C**	Bearing Container Shim (0.015 in.)	100695	A.R.
43D**	Bearing Container Shim (0.030 in.)	100696	A.R.
44	Brake Housing	11274	1
45	Brake Housing Gasket	11661	1
46	Brake Rotor Assembly		
	S/N 7211319 and lower	81041	1
	S/N 7211320 and higher	81491	1

ITEM	DESCRIPTION	PART NO.	QTY.
47	Brake Rotor Key		
	S/N 7211319 and lower	23367	1
	S/N 7211320 and higher	10163	1
48	Pressure Plate	22778	1
49	Brake Spring Assembly	81044	1
50	Brake Adjusting Nut (included in item 49)	11263	1
51	Adjusting Nut Washer	11600	1
52	Adjusting Nut Gasket	11601	1
53	Adjusting Plate	11602	1
54	Clutch Lever	11676	1
55	Clevis Pin	12751	2
56	Clevis	11578	2
57	Clevis Link	11677	1
58	Control Shaft	11667	2
60	Control Shaft Support Bracket	11668	1
61	Collar	11669	6
62	Brake Lever	11678	1
65	Level Plug (see note on back page)	18009	1
66	Drain Plug	18010	1
67	Capscrew (3/8 - 16 X 1 3/4 G8 Z)	104311	4
68	Capscrew (5/8 - 18 X 2 1/4 G8 Z)	11475	3
69	Capscrew (5/8 - 11 X 2 G8 Z)	72563	6
70	Clutch Plate Capscrew (5/8 - 18 G8)		
	S/N 6005645 and lower (2 1/4 in.)	11475	8
	S/N 6005646 and higher (2 3/4 in.)	13982	8
71	Capscrew (7/8 - 9 X 3 ASTM A574)	23100	4
72	Capscrew (7/8 - 9 X 3 ASTM A574) S/N 9653312 and lower	23100	4
	Capscrew (7/8 - 9 X 2-1/4 NC GD8 Z) S/N 9653313 and higher	70528	4
73	Capscrew (1 - 8 X 3 1/2 Hyv. Structural)	103580	12
74	Collar Set Screw	13957	6
75	Hex Nut (3/8 - 16)	11780	6
76	Hex Nut (1/2 - 20)	22701	8

ITEM	DESCRIPTION	PART NO.	QTY.
78	Hex Nut (1 - 8 Heavy)	22887	12
79	Lockwasher (5/8 in.)	102423	15
	Lockwasher (5/8 in.)		
80	S/N 9653312 and lower (external tooth)	13449	6
	S/N 9653313 and higher (sealing)	72146	6
81	Lockwasher (7/8 in.)	13447	8
82	Hex Nut (5/8 - 18)	22702	7
84	Capscrew (5/8 - 18 X 2 G8 Z)	22699	4
85	Lockwasher (1)	13986	12
86	Cotter Pin	18008	4
87	Grease Fitting	18047	6
89	Lockwasher (3/8)	27152	6
90	Lockwasher (1/4)	11015	2
91	Plain Washer (1/4)	11072	2
92	Capscrew (1/4 - 20 X 1/2 G8 Z)	22727	2
93	Capscrew (5/16 - 24 X 3/4 G8 Z)	32265	1
94	Lockwasher (5/16)	11024	1
95	Capscrew (1/4 - 28 X 3/8 special)	13630	6
96	Retaining Ring	11670	1
97	Cotter Pin (clutch pivot - not shown)	13959	1
98	Capscrew (5/16 - 18 X 3/4 G8 Z)	11763	2
99	Cable Clamp	29036	1
100	Lockwasher (3/4)	13435	2
101	Hex Nut (3/4 - 10)	11791	2
102	Level Plug (see note on back page)	19034	1

A.R. - As Required

*Part Number 100768 identified by a machined groove on the outside diameter.

**NOTE: Units with O-Rings on the bearing containers DO NOT use gaskets (item 43). Use shims (items 43A-43D) to set worm shaft end play. NO gasket or shims required on brake end bearing container. Gasket (item 45) between bearing container and brake housing is still required.

***Current worm housing and cover bushings are grooved for a quad ring. When grooved bushings are installed in an older winch, the quad rings can be installed in the bushings without any other modifications to the winch.