

# BRADEN

## Hydraulic Worm Gear Winches

35,000 to 100,000 lb Rating

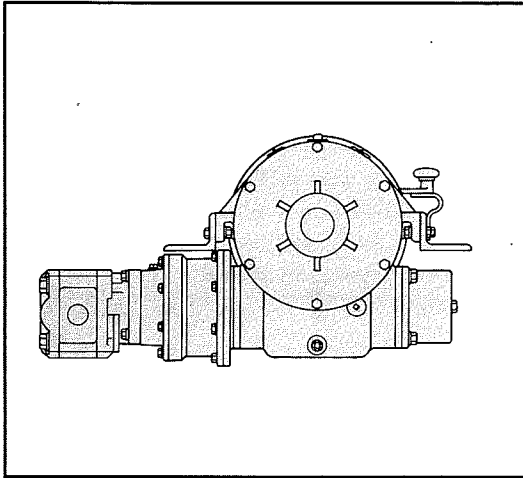

Low Mount

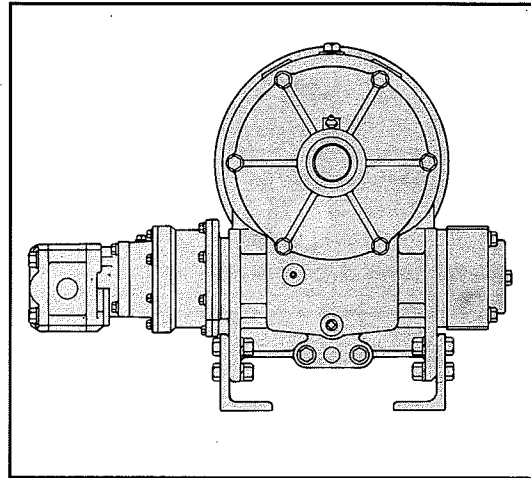

Upright

**Complete With High Efficiency Planetary Adapter & WM Series Commercial Shearing Hydraulic Motor**

### Low Mount

- **AMSU12-12F ➔ AHSU12P-12F**  
(35,000 lbs. 1st LAYER)

### Upright

- **AMS20-18B ➔ AHS20P-18B**  
(45,000 lbs. 1st LAYER)
- **MS30-20B ➔ HS30P-20B**  
(60,000 lbs. 1st LAYER)
- **MS50-20B ➔ HS50P-20B**  
(100,000 lbs. 1st LAYER)

# Performance

<ul style="list-style-type: none"> <li>• <b>AHSU12P</b> 35,000 lbs.</li> <li>• 7.75:1 Adapter with WM51 4.46 cu. in. Motor</li> <li>• 2300 PSI @ flows up to 50 GPM (1600 PSI Dynamic)</li> <li>• 35,000 lbs. 1st Layer Line Pull</li> <li>• 15 FPM 1st Layer Line Speed</li> </ul>	<ul style="list-style-type: none"> <li>• <b>AHS20P</b> 45,000 lbs.</li> <li>• 7.75:1 Adapter with WM51 5.10 cu. in. Motor</li> <li>• 2700 PSI @ flows up to 65 GPM (2100 PSI Dynamic)</li> <li>• 45,000 lbs. 1st Layer Line Pull</li> <li>• 18 FPM 1st Layer Line Speed</li> </ul>
<ul style="list-style-type: none"> <li>• <b>HS30P</b> 60,000 lbs.</li> <li>• 7.75:1 Adapter with WM76 9.03 cu. in. Motor</li> <li>• 2500 PSI @ flows up to 75 GPM (1650 PSI Dynamic)</li> <li>• 60,000 lbs. 1st Layer Line Pull</li> <li>• 13 FPM 1st Layer Line Speed</li> </ul>	<ul style="list-style-type: none"> <li>• <b>HS50P</b> 100,000 lbs.</li> <li>• 7.75:1 Adapter with WM76 12.04 cu. in. Motor</li> <li>• 3000 PSI @ flows up to 85 GPM (2200 PSI Dynamic)</li> <li>• 100,000 lbs. 1st Layer Line Pull</li> <li>• 12 FPM 1st Layer Line Speed</li> </ul>

	A	B	C	D MOTOR PORTS
AHS20P	7.88	14.83	37.96	1" Split Flange
HS30P	9.00	16.50	39.70	1½" Split Flange
HS50P	9.75	17.07	44.09	1½" Split Flange

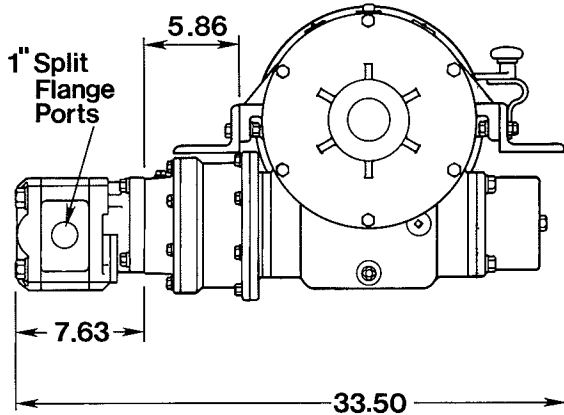

AHSU12P Dimensional

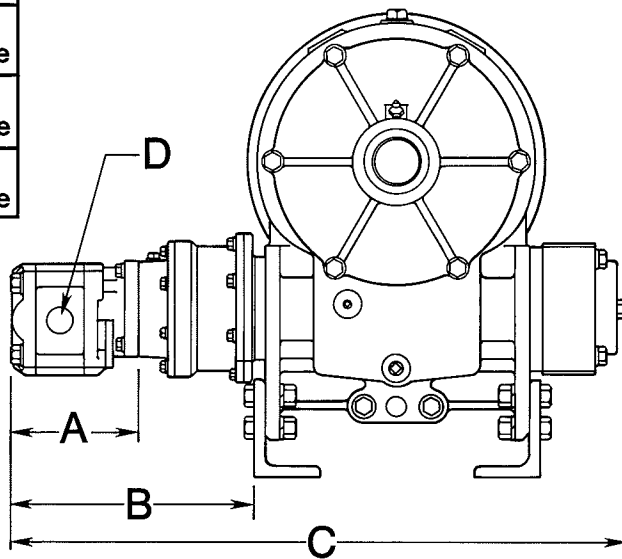

AHS20P Dimensional  
HS30P Dimensional  
HS50P Dimensional

