

BRADEN[®]

CH640 PLANETARY HOIST MATERIALS LIST

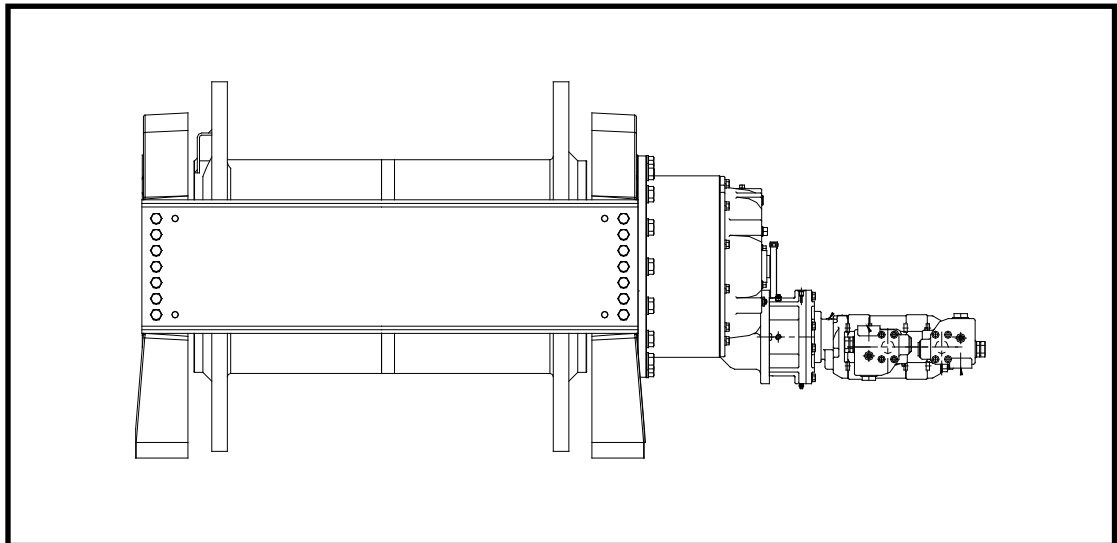

This page intentionally left blank

FOREWORD

The following service instructions have been prepared to provide assembly, disassembly and maintenance information for the BRADEN Model CH640 Hoist. It is suggested that before doing any work on these units, all assembly and disassembly instructions should be read and understood.

Some pictures in this manual may show details or attachments that are different from your unit. Also, some components have been removed for illustrative purposes.

Continuing product improvement may cause changes in your unit, which are not included in this manual. Whenever a question arises regarding your BRADEN Hoist or this manual, please contact BRADEN Technical Support Department for the latest available information at P. O. Box 547, Broken Arrow, Oklahoma 74013, 918-251-8511, 08:00-16:30 hours, CT, Monday through Friday.

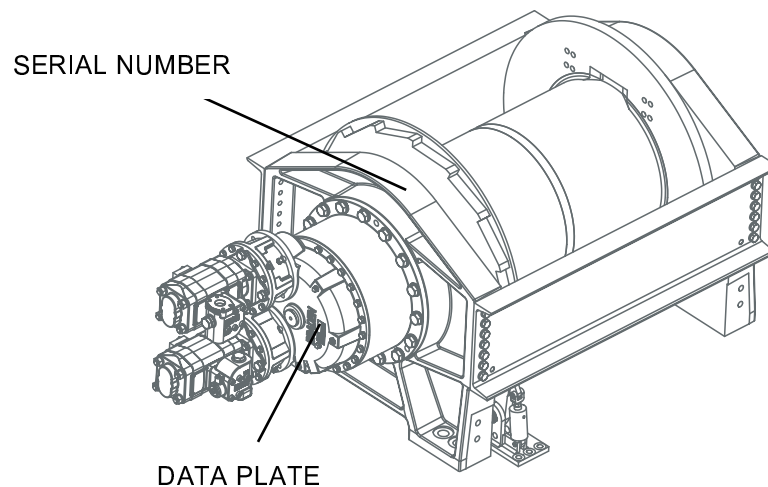

MODEL NUMBER AND SERIAL NUMBER

When information on a hoist is needed, always refer to the model number and serial number. Both are located on the top of the motor side end plate as indicated above.

EXPLANATION OF MODEL NUMBER

CH	640	A	-	102	D	108	01	P	-	1
CONSTRUCTION HOIST	MAX RATING	DESIGN MODEL		GEAR RATIO	DUAL MOTORS	MOTOR SIZE	DRUM SIZE	DRUM OPTION		OPTION

- CH** DESIGNATES CONSTRUCTION HOIST
- 640** DESIGNATES 64,000 LB MAXIMUM FIRST LAYER LINE PULL
- A** DESIGNATES THE MODEL SERIES RELATING TO DESIGN CHANGES
- 102** DESIGNATES TOTAL GEAR REDUCTION
- D** DESIGNATES DUAL MOTORS
- 108** DESIGNATES HYDRAULIC MOTOR DISPLACEMENT IN CU IN/REV (DECIMAL POINT ELIMINATED
EXAMPLE 108 -10.8 CU IN/REV)
- 01** DESIGNATES THE DRUM OPTION SIZE
- P** DESIGNATES OTHER DRUM OPTIONS (P = RATCHET AND PAWL)
- 1** PERMITS TESTING AND INSPECTION PER API2C FOR OFFSHORE CRANES

CH640 COMMON PARTS

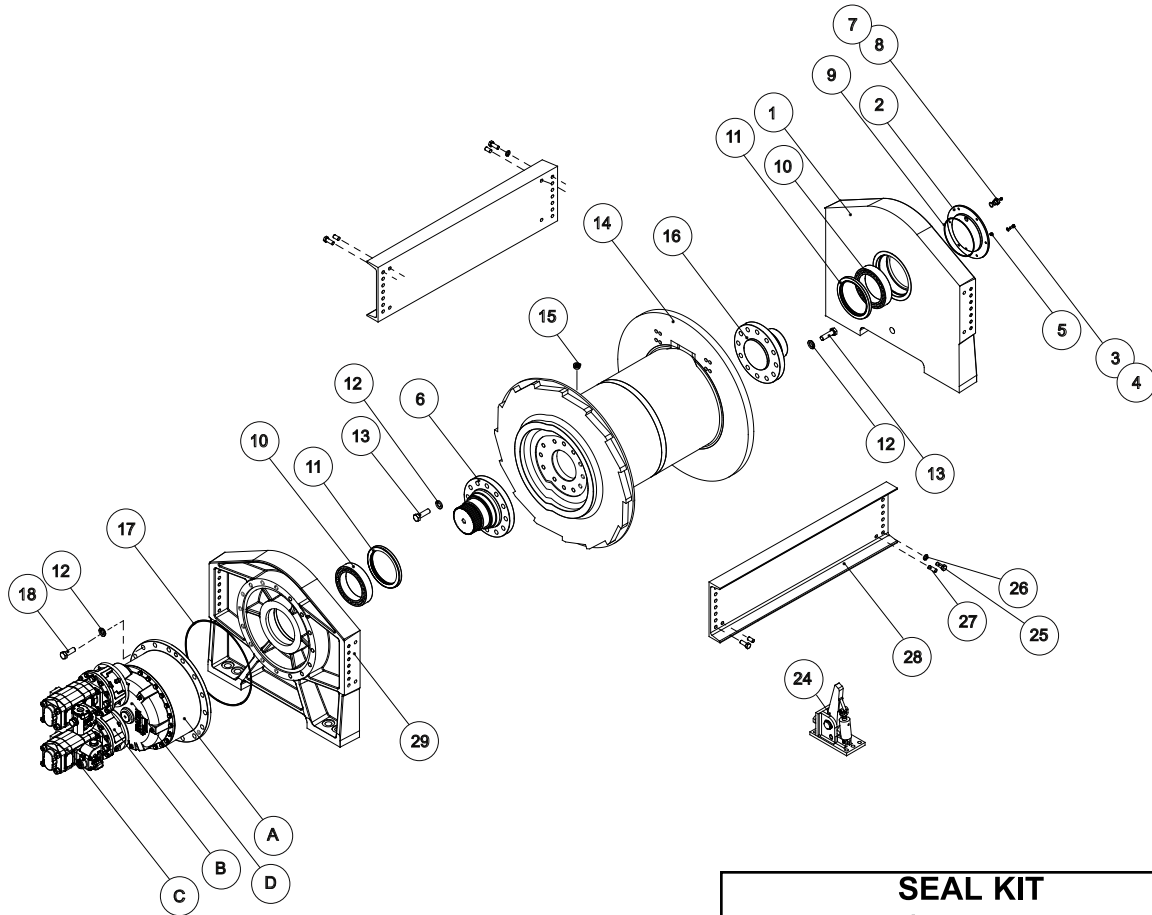

SEAL KIT
P/N - 63844
All seals required for servicing either dual or single motor units; Any gear ratio.

ITEM NO.	DESCRIPTION	PART NO.	QTY.
A	Drive Group (102:1/96:1)	63297	1
	Drive Group (128:1)	63292	1
	Drive Group (102:1)	63224	1
B	Brake Group	82903	1
C	Motor Group (102:1/96:1)	83001	1
	Motor Group (96:1)	83081	1
	Motor Group (128:1)	82906	1
	Motor Group (102:1)	82937	1
D	Input Assembly	82936	1
1	Sideplate, Support End	103509	1
2	Cover, Sideplate	103069	1
3	Lockwasher (3/8)	27152	6
4	Capscrew (3/8 - 16 X 1 GD8)	104309	6
5	Grease Fitting	18047	1
6	Support Shaft	103067	1
7	Fill-Vent Plug	29678	1
8	Relief Valve	10074	1
9	O'Ring	72109	1
10	Bearing, Spherical Roller	103064	2
11	Lipseal	103065	2

ITEM NO.	DESCRIPTION	PART NO.	QTY.
12	Washer, Hard (1 inch)	101205	40
13	Capscrew (1 - 8 X 3 1/2 GD8)	103580	24
14	Cable Drum (102:1/96:1)	103577	1
	Cable Drum (128:1/96:1)	103304	1
	Cable Drum (102:1)	103066	1
	Cable Drum (96:1)	103907	1
15	Plug	24420	1
16	Drive Shaft	103063	1
17	O'Ring	26373	1
18	Capscrew (1 - 8 X 3 GD8)	102597	16
22	Capscrew (Not Shown) (3/4 - 10 X 6 GD8)	104176	8
24	R+P Bracket Assy (102:1)	63276	1
25	Capscrew (3/4 - 10 X 2 1/2 GD8)	78453	28
26	Lockwasher (128:1/102:1/96:1) (3/4)	13435	36
27	Cl. Plt. Dowel Pin	12769	8
28	Tieplate (102:1/96:1)	103583	2
	Tieplate (128:1/96:1) (02 Drum)	103275	2
	Tieplate (102:1) (01 Drum)	103270	2
29	Sideplate, Drive End	102855	1
30	O'Ring (Not Shown)	10052	2

CH640 BRAKE

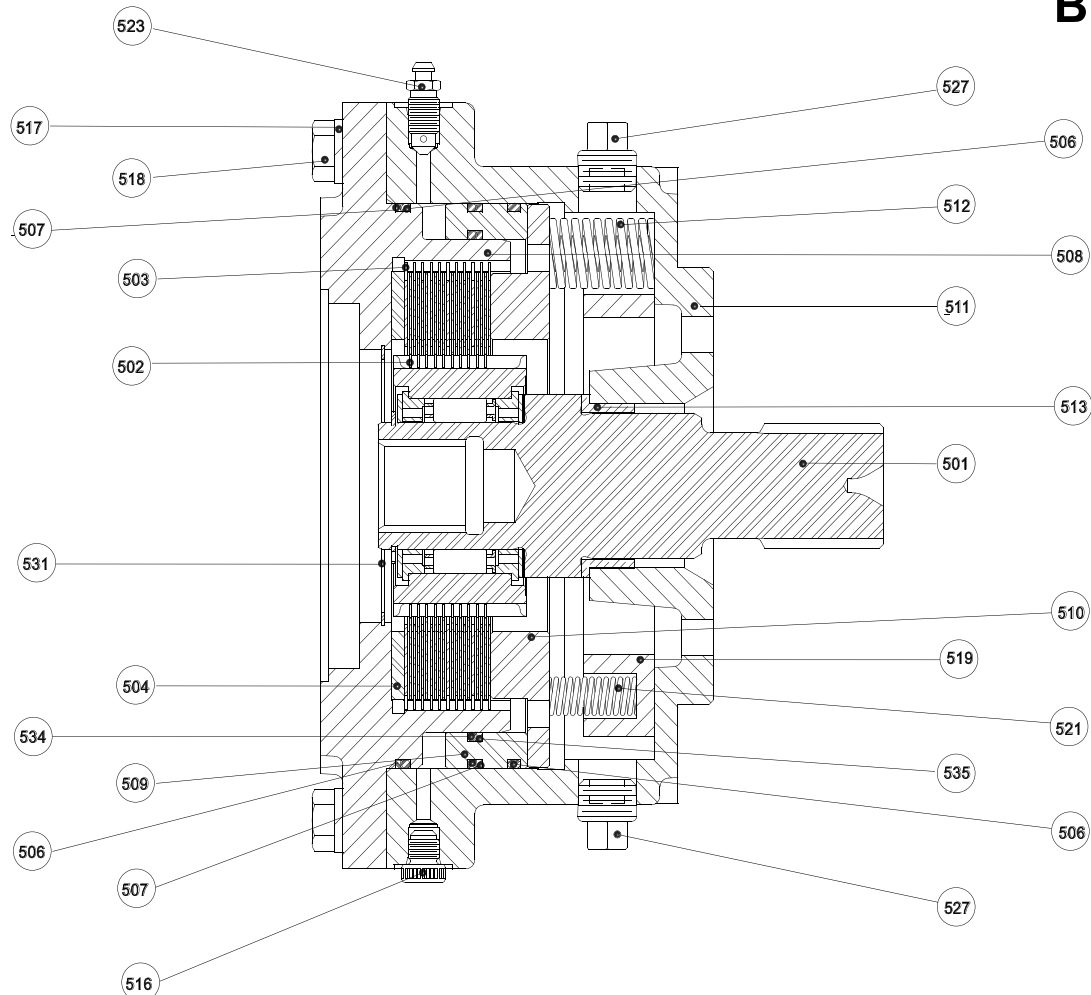

NOTE: Before ordering, verify brake parts with CH640A serial number because of the number of brakes used.

ITEM NO	DESCRIPTION	PART NO.	QTY.
501	Sprag Clutch Assy (128:1; 102:1; 96:1)	82904	1
	Sprag Clutch Assy (66:1)	83466	1
502	Friction Disc	102716	10
503	Brake Disc	24490	11
504	Spacer	27366	1
506	O'Ring	102271	3
507	Back-up Ring	102272	2
508	Motor Adapter	29655	1
509	Piston	100030	1
510	Pressure Plate	100031	1
511	Brake Housing	40066	1
512	Die Spring	27444	12
513	Bushing	27367	1
516	Shipping Hyd. Plug	25403	1
517	Lockwasher	11026	8
518	Capscrew	104322	8
519	Spring Separator	52998	1
521	Shftr Fork Spring	11310	3
523	Bleeder Fitting	27472	1
527	Magnetic Pipe Plug	72215	2
531	Internal Retaining Ring	29804	1
534	O'Ring	100032	1
535	Back-up Ring	100033	1
540	Motor Adapter (Not Shown) (66:1)	106553	1
541	O'Ring (Not Shown) (66:1)	10330	1

SAE D BRAKE (PART NUMBER 83077)

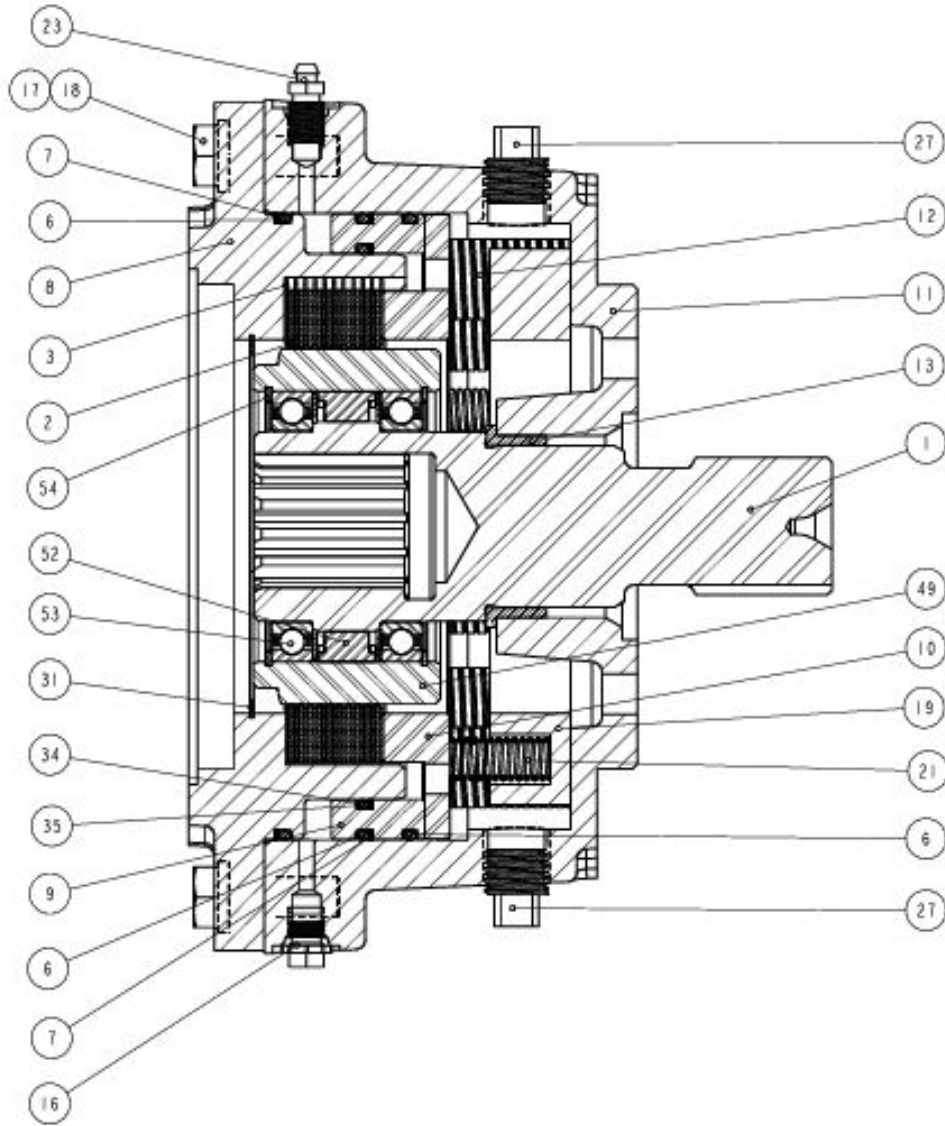

NOTE: Before ordering, verify brake parts with CH640A serial number because of the number of brakes used.

SAE D BRAKE (PART NUMBER 83077)			
ITEM #	DESCRIPTION	PART #	QTY.
000	Sprag clutch assembly	83078	1
002	Friction disc	104138	10
003	Brake disc	102954	11
006	O-ring	102271	3
007	Backup ring	102272	2
008	Motor adapter	103884	1
009	Piston	100030	1
010	Pressure plate	103850	1
011	Brake housing	40066	1
012	Die spring	27444	12
013	Bushing	27367	1

SAE D BRAKE (PART NUMBER 83077)			
ITEM #	DESCRIPTION	PART #	QTY.
016	Shipping plug, hydraulic	25403	1
017	Lockwasher	11026	8
018	Capscrew	104322	8
019	Spring separator	52998	1
021	MU-143S shifter fork spring	11310	3
023	Bleeder fitting	27472	1
027	50530 Pipe plug, magnetic	72215	2
031	Ring, internal retaining	103882	1
034	O-ring	100032	1
035	Backup ring	100033	1

CH640 CABLE ANCHOR ASSEMBLY

ITEM NO.	DESCRIPTION	PART NO. 63281	QTY.
801	Cable Anchor	103467	1
802	Nut, Hex	101439	1
803	Cable Clamp Rod	103468	1
804	Cable Clamp	103466	1
805	Washer	100859	1
806	Nut, Self-Locking	29659	1

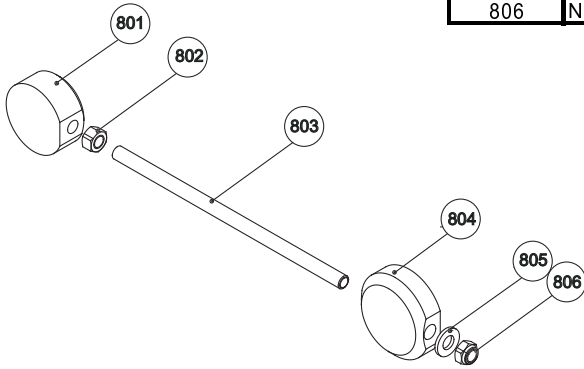

SPRAG CLUTCH ASSEMBLY

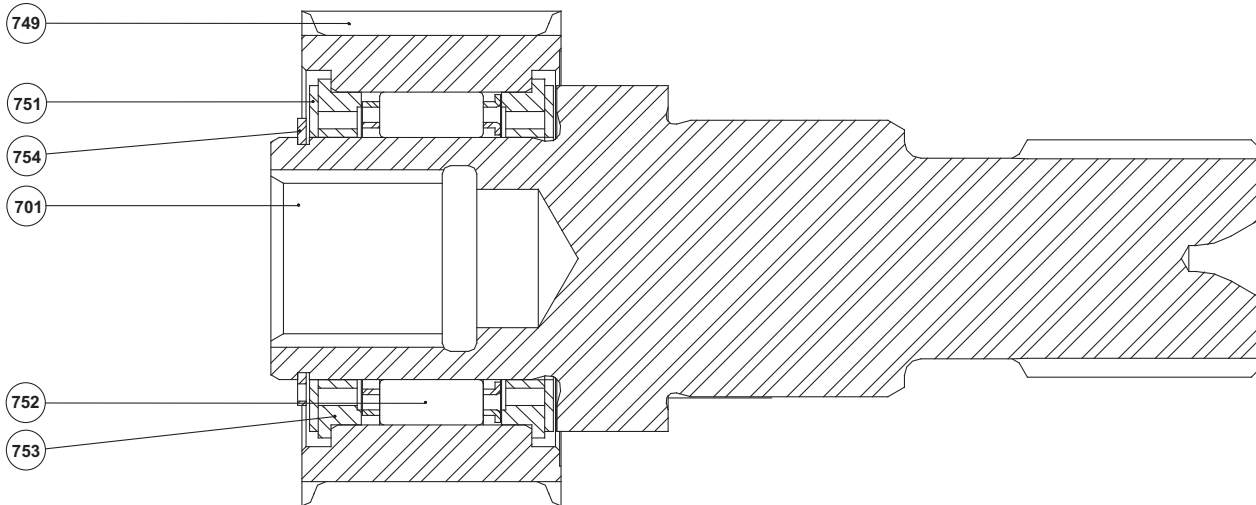

ITEM NO.	DESCRIPTION	PART NO.	QTY.
701	Brake Shaft (128:1; 102:1; 96:1)	103034	1
	Brake Shaft (2-Bolt SAE "C" Shaft Only)	106552	1
749	Outer Brake Race	24863	1
751	Thrust Bearing	24581	2
752	Sprag Clutch	24839	1
753	Sprag Bearing	27684	2
754	Snap Ring	12034	1

CH640 DRIVE / INPUT ASSEMBLY

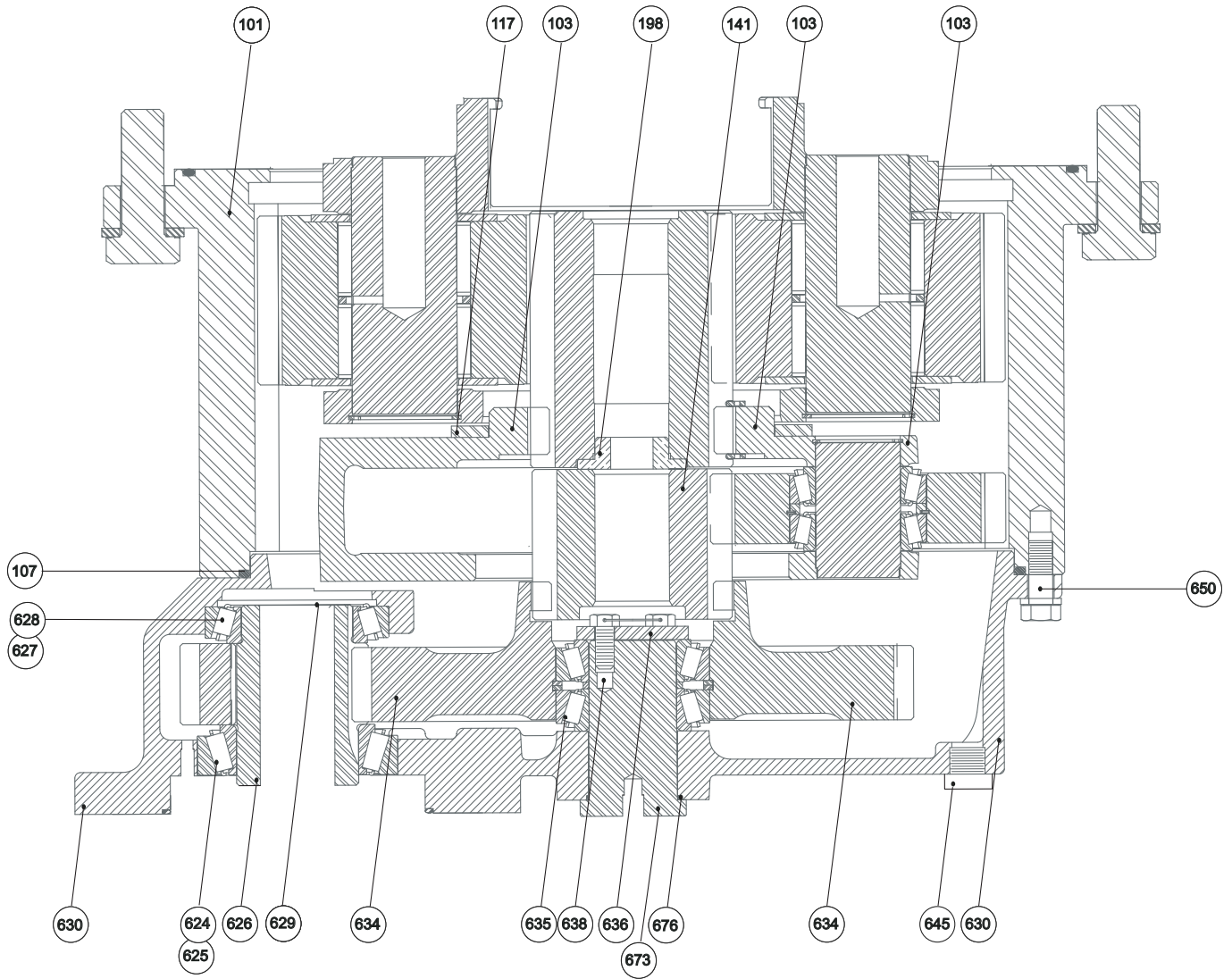

CH640 DRIVE ASSEMBLY

ITEM NO.	DESCRIPTION	PART NO.	QTY.
101	Ring Gear	103266	1
102	Final Planet Carrier Assy	82905	1
103	Primary Planet Carrier Assy	82444	1
105	Capscrew	26396	16
106	Lockwasher (102:1; 96:1; 66:1)	24128	16
107	O'Ring	26382	1
117	Carrier Spacer	101246	1
141	Primary Sun Gear	100245	1
155	Sight Gage (128:1)	103464	1
166	Nameplate	76381	1
167	Drive Screw	11842	4
198	Thrust Bearing	101493	1

INPUT ASSEMBLY

ITEM NO.	DESCRIPTION	PART NO.	QTY.
624	Bearing Cup (128:1)	26383	1
	Bearing Cup (102:1; 96:1; 66:1)	26383	2
625	Bearing Cone (128:1)	26384	1
	Bearing Cone (102:1; 96:1; 66:1)	26384	2
626	Pinion (128:1)	29034	1
	Pinion (102:1; 96:1; 66:1)	29606	2
627	Bearing Cup (128:1)	26386	1
	Bearing Cup (102:1; 96:1; 66:1)	26386	2
628	Bearing Cone (128:1)	26387	1
	Bearing Cone (102:1; 96:1; 66:1)	26387	2
629	Bearing Retainer (128:1)	26388	1
	Bearing Retainer (102:1; 96:1; 66:1)	26388	2
630	Input Housing (128:1)	101018	1
	Input Housing (102:1; 96:1; 66:1)	29942	1
634	Bull Gear (128:1)	29035	1
	Bull Gear (102:1)	29607	1
	Bull Gear (96:1)	29261	1
	Bull Gear (66:1)	29052	1
635	Bearing Assy	26393	1
636	Retainer Plate	26394	1
638	Capscrew	26395	3
645	Mag Pipe Plug (128:1)	31392	2
646	Plug (128:1)	23095	1
647	Reducer Bshg	18066	1
648	Relief Valve	18062	1
649	Mag Pipe Plug (128:1)	72215	3
	Mag Pipe Plug (102:1; 96:1; 66:1)	72215	4
650	Capscrew (128:1)	21043	6
	Capscrew (102:1; 96:1; 66:1)	21043	12
653	Pinion Gear (66:1)	29051	2
655	Sight Glass (102:1; 96:1; 66:1)	103555	1
673	Bull Gear Shaft	29247	1
676	O'Ring	29955	1

CH640 PRIMARY PLANET GEAR

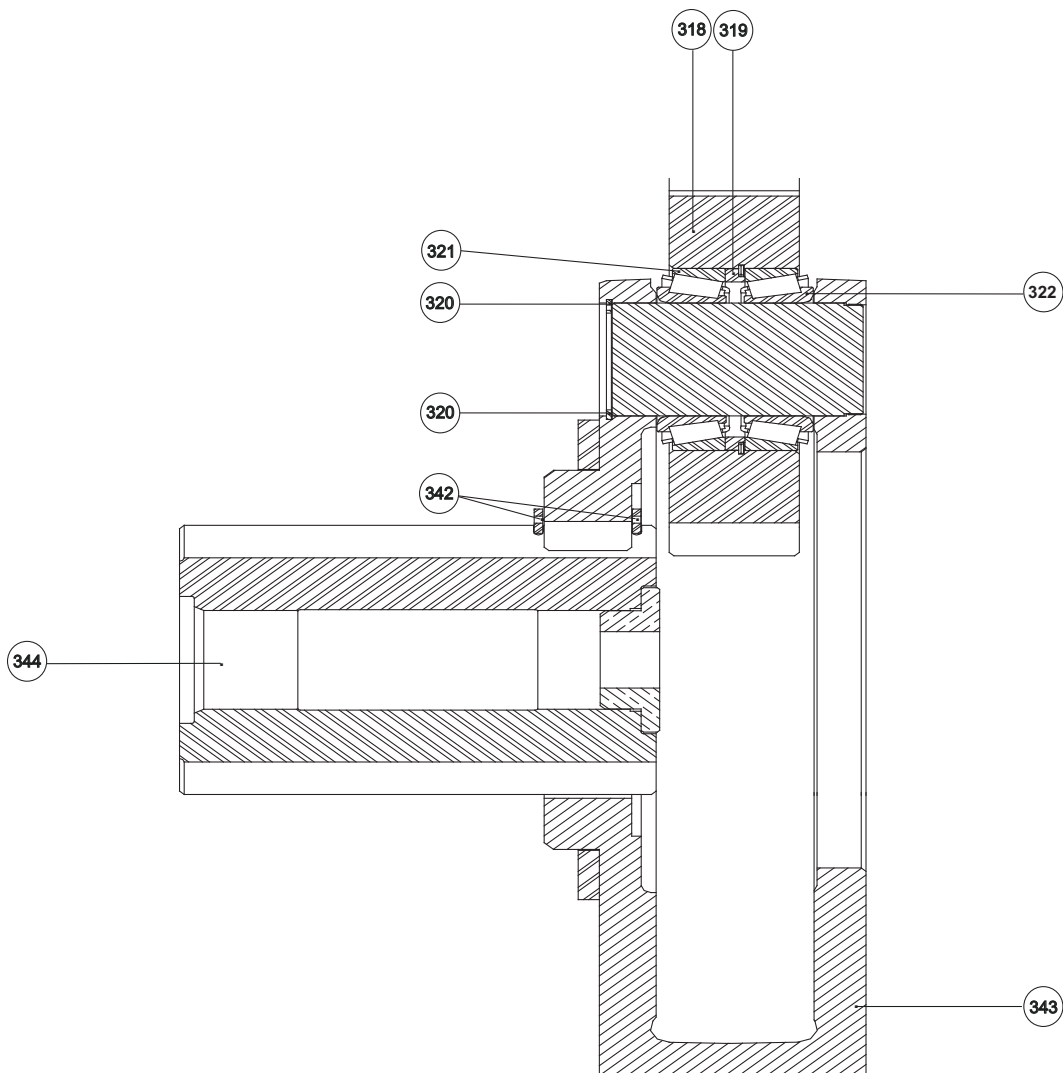

ITEM NO	DESCRIPTION	PART NO. 82444	QTY.
318	Primary Planet Gear	26377	3
319	Bearing Spacer	26378	3
320	Snap Ring	26379	3
321	Bearing Cup	30952	3
322	Bearing Cone	26381	6
342	External Retaining Ring	28721	2
343	Primary Planet Carrier	101210	1
344	Final Sun Gear	101212	1
351	Primary Planet Pin	101108	3
352	Internal Retaining Ring (Not Shown)	101140	3

CH640 FINAL PLANET CARRIER

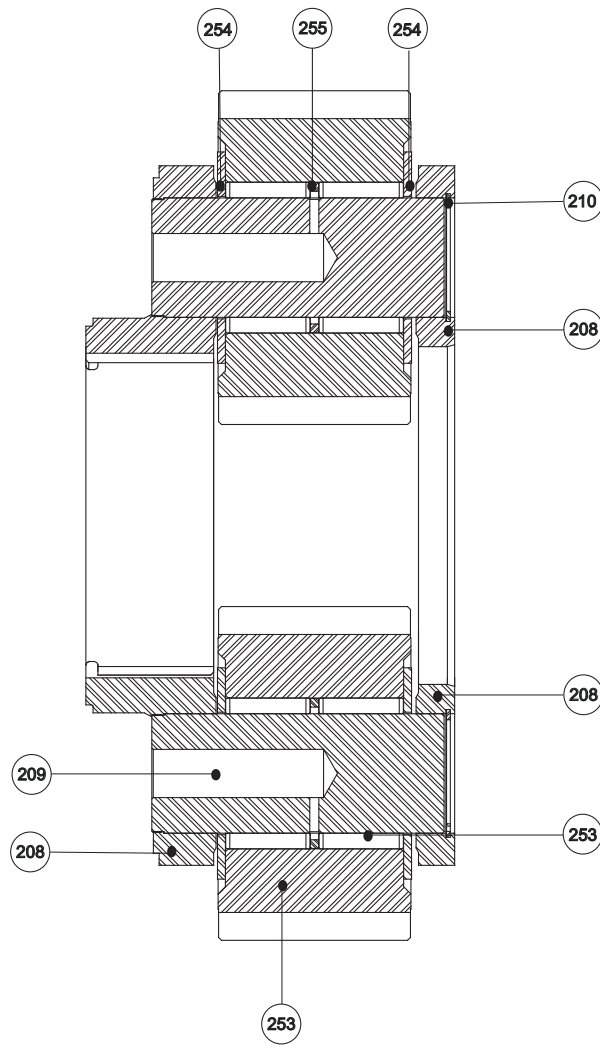

ITEM NO.	DESCRIPTION	PART NO. 82905	QTY.
208	Final Planet Carrier	103061	1
209	Final Planet Pin	102137	1
210	Snap Ring	24341	4
215	Final Planet Gear	102136	4
253	Roller	102139	216
254	Thrust Washer	29002	8
255	Bearing Spacer	102138	4

CH640

HYDRAULIC MOTORS

ITEM NO.	DESCRIPTION	PART NO.	QTY.
401	Adapter (128:1)	25864	3
	Adapter (102:1; 96:1)	25864	2
402	Male Union 45 Degree (128:1)	70122	2
	Male Union 45 Degree (102:1(01P); 96:1(02))	70122	1
403	Tee-Female Pipe (128:1)	23769	1
	Tee-Female Pipe 102:1; 96:1)	23769	2
404	Needle Valve (128:1)	25258	1
	Needle Valve (102:1 (01P)(22)/96:1(02))	25258	2
405	Elbow-Street 45 Deg. (128:1/102:1(01P)/96:1(02))	13709	1
406	Swivel Tee (128:1)	25748	1
	Swivel Tee (102:1/96:1)	25748	2
407	Cap Nut (128:1)	70182	1
	Cap Nut (102:1/96:1)	70182	2
408	Hose Assy (128:1)	13705	2
	Hose Assy (96:1 (22/23))	13705	4
409	Hose Assy (128:1)	13706	1
	Hose Assy (102:1(22)/96:1(22/23))	13706	2
410	Capscrew (128:1)	104323	8
411	CF Manifold Spacer (128:1/102:1(01P)/96:1(02))	103483	2
	CF Manifold Spacer (102:1(22)/96:1(22/23))	103483	4
412	Brake Valve Assy (128:1/102:1(01P)/96:1(02))	81609	2
	Brake Valve Assy (102:1(22)/96:1(22/23))	81609	4
413	Lockwasher (128:1)	11026	4
	Lockwasher (102:1/96:1)	11026	8
414	Hose Assy (102:1(22))	13707	4
415	Capscrew (128:1/102:1(01P)/96:1(02))	23690	8
	Capscrew (102:1(22)/96:1(22/23))	23690	16
416	Fitting Cap (128:1)	75281	1
417	Straight Adapter (128:1/96:1(22/23))	103473	1
	Straight Adapter (102:1(01P)/102:1(22)/96:1(02))	103473	1
418	Bolted Flange Protector	100169	4
419	Hose Assy (102:1(01P)/96:1(02))	25749	1
420	Hose Assy (102:1(01P)/96:1(02))	25935	2
421	Hydraulic Motor - WM365 Tandem (128:1)	103264	1
	Hyd. Motor - WM365 Tandem 12.6 (102:1(22))	103584	2
	Hyd. Mtr. - WM365 Tandem 10.8 (96:1(22/23))	103607	2
	Hyd. Mtr. - WM365 Tandem (102:1(01P)/96:1(02))	103269	2
422	Elbow-Street 90 Deg (102:1(22)/96:1(22/23))	13708	2
423	Hose Assy (102:1(01P))	34199	1
424	Hose Assy (102:1(01P))	78435	1
425	Hose (102:1(01P))	100562	1
426	Elbow TBG FTG (102:1(01P))	21163	5
	Elbow TBG FTG (96:1(02))	21163	2
427	Elbow Fitting (102:1(22)/96:1(22/23))	25302	4
	Elbow Fitting (102:1(01P)/96:1(02))	25302	2
428	Elbow, 45 Degree (102:1(01P)/102:1(22)/96:1(02)/96:1(22/23))	27149	1
429	Adapter (102:1(01P)/102:1(22)/96:1(02)/96:1(22/23))	104142	1
430	JIC Reducer (102:1(01P)/102:1(22)/96:1(02)/96:1(22/23))	100505	1
431	Swivel Nut Branch Tee (102:1(01P)/102:1(22)/96:1(02)/96:1(22/23))	76610	1
432	Cap (102:1(01P)/102:1(22)/96:1(02)/96:1(22/23))	29908	1
433	Hose Assy (102:1(01P)/102:1(22)/96:1(02)/96:1(22/23))	29657	1
434	Capscrew (102:1(22))	104322	16
	Capscrew (102:1(01P)/96:1(02)/96:1(22/23))	104322	12
435	Hose Assy (102:1(01P))	25750	1
	Hose Assy (96:1(02))	25750	2
436	Male Run Tee (102:1(01P)/96:1(02))	24526	1
437	Male Connector (102:1(01P)/96:1(02))	21219	1
438	Tee Swivel Nut Run (102:1(01P))	70583	1
439	Swivel Tee (102:1(01P)/96:1(02))	26002	1
440	Reducer Adapter (102:1(01P))	27396	1

CH640 HYDRAULIC MOTOR (82906)

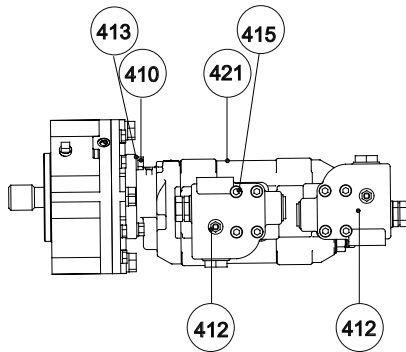
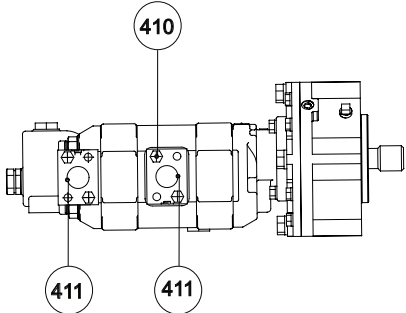
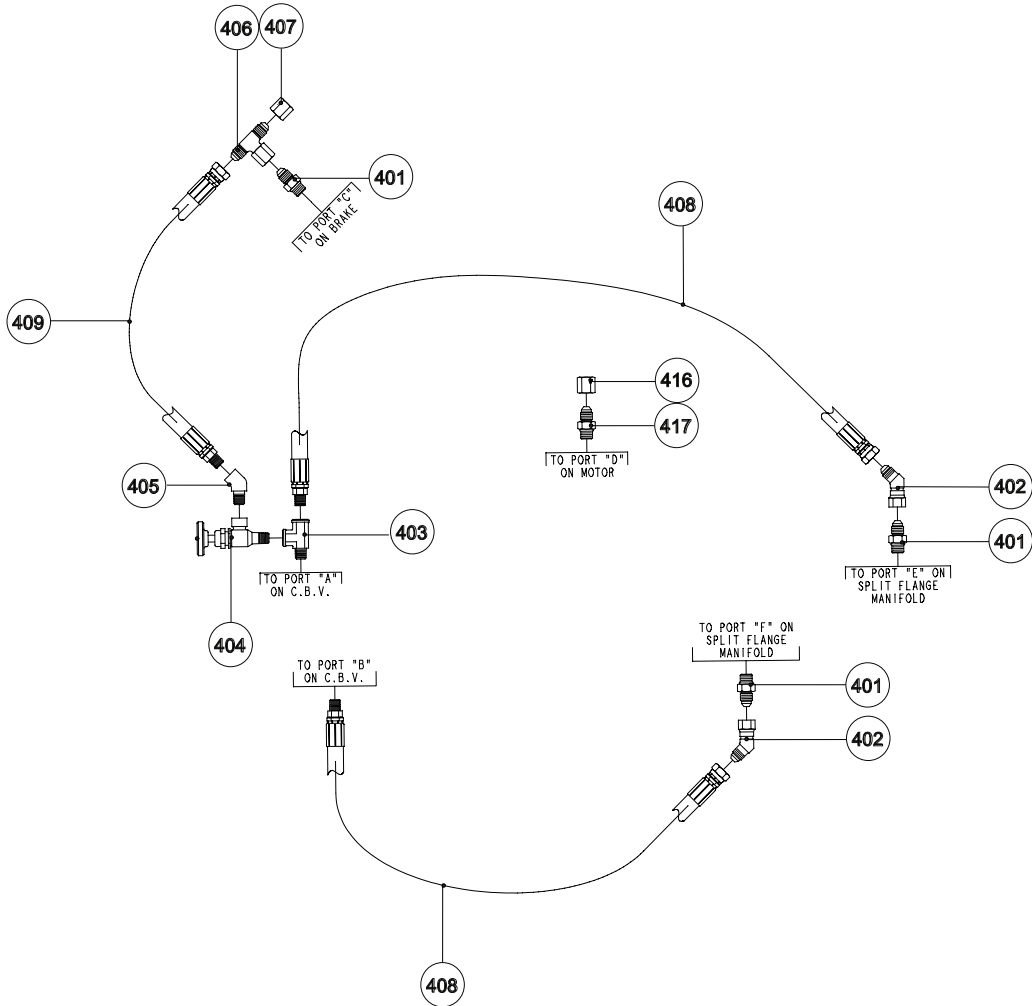

CH640 HYDRAULIC MOTOR (82937)

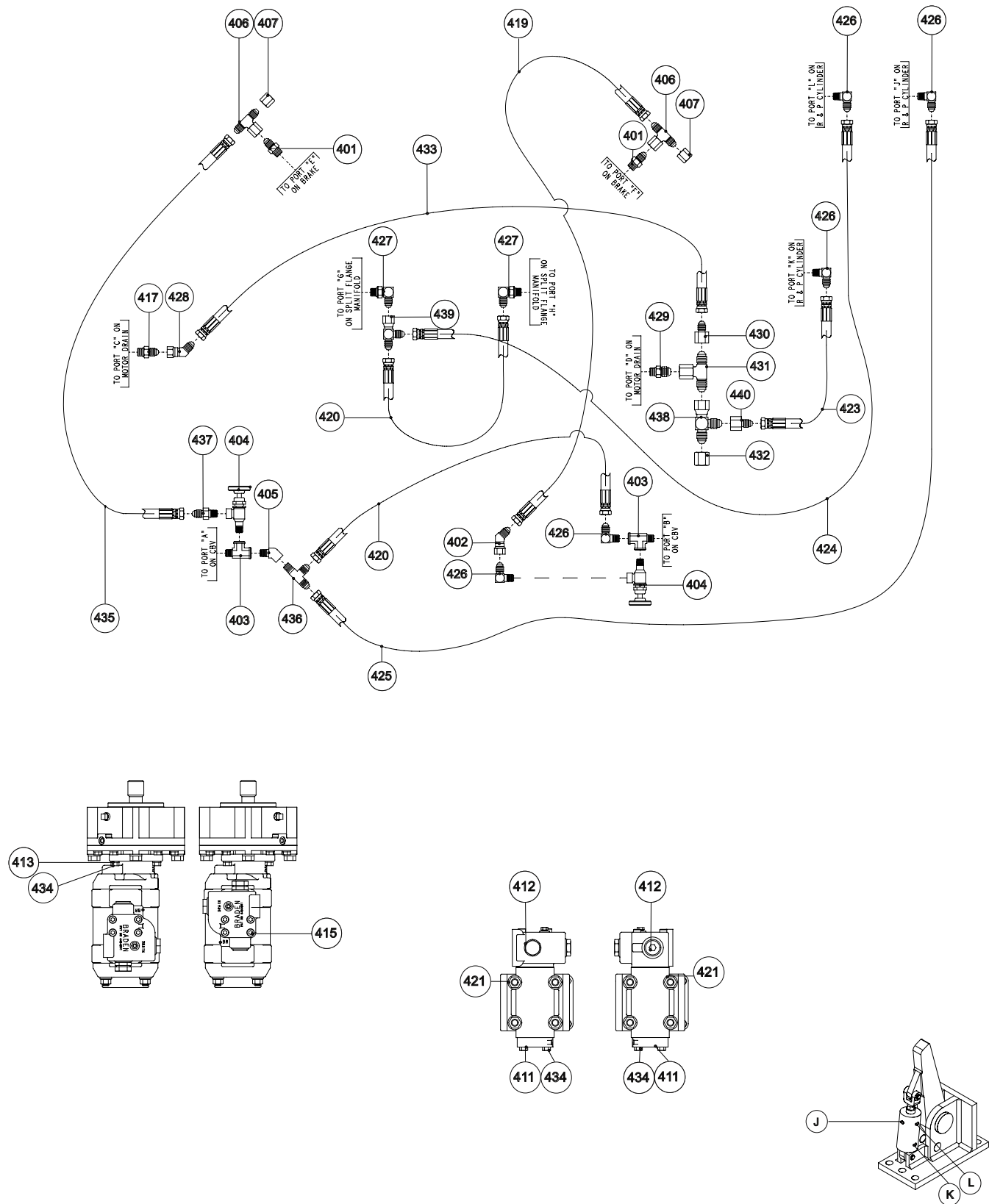

CH640 HYDRAULIC MOTOR (82986)

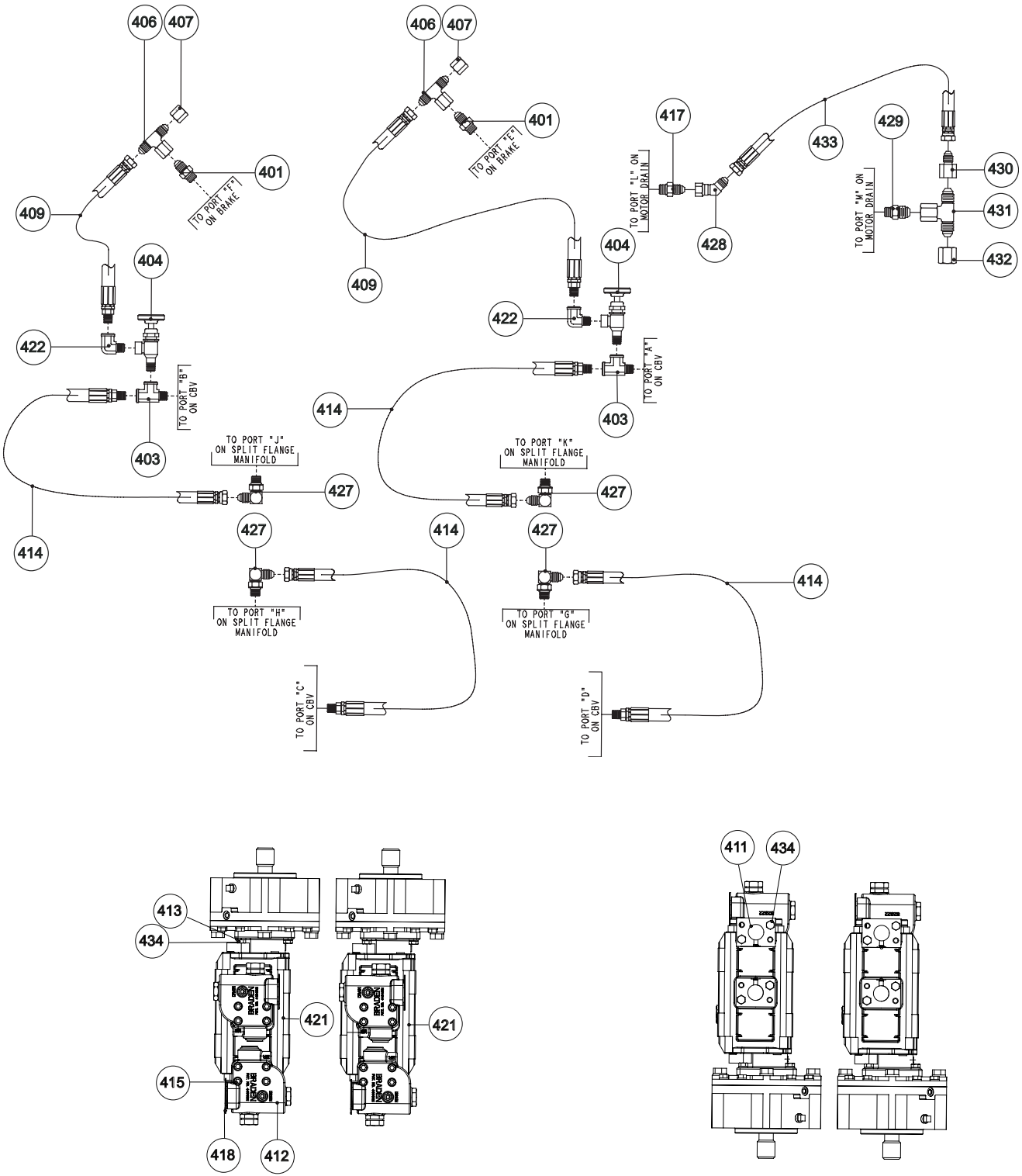

CH640 BRAKE VALVE HOUSING

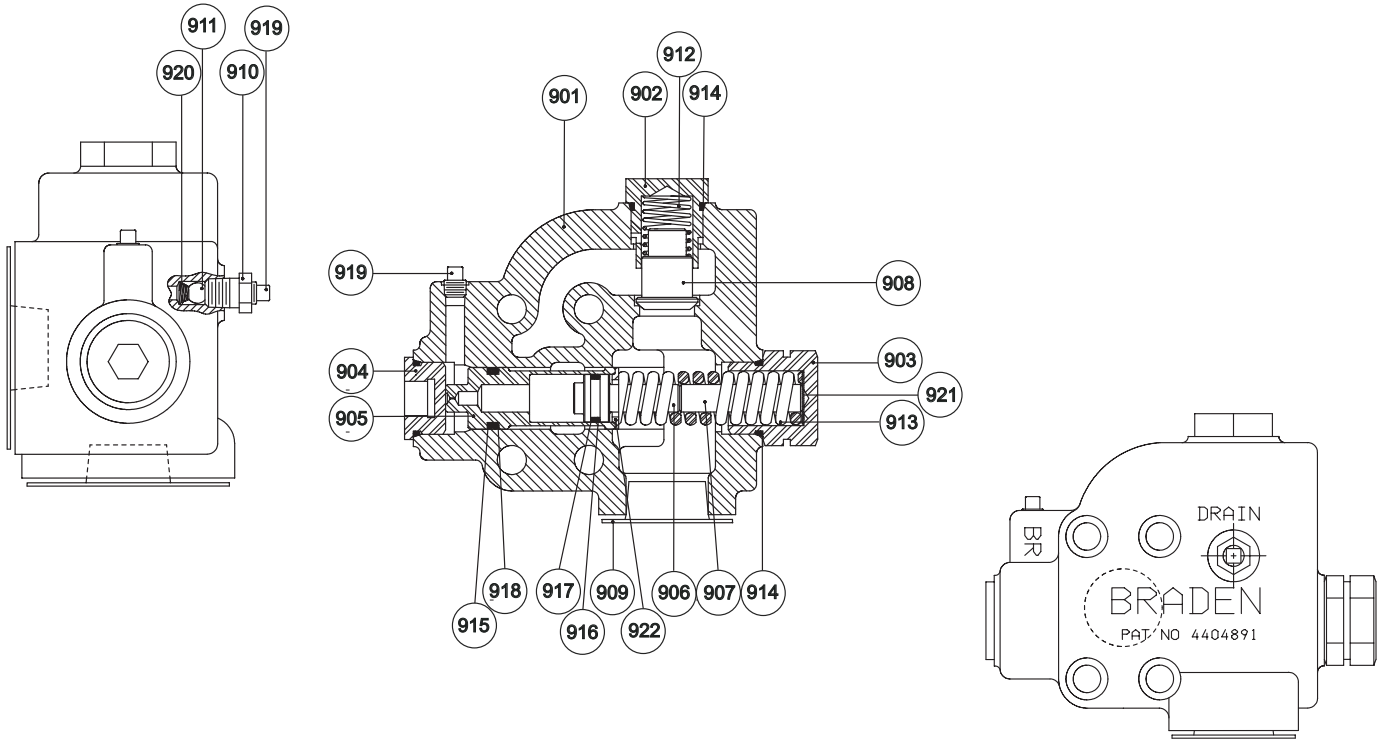

ITEM NO.	DESCRIPTION	PART NO. 81609	QTY.
901	Brake Valve Housing	24118	1
902	Valve Spring Retainer	24424	1
903	Spring Retainer	101016	1
904	Plug	24420	1
905	Brake Valve Piston	24429	1
906	Damper Piston	24425	1
907	Damper Piston Extension	101017	1
908	Check Valve Poppet	24423	1
909	Shipping Plug	25036	2
910	Reducer	24436	1
911	Ball, Steel	24428	1
912	Check Valve Spring	24190	1
913	Main Piston Spring	24434	1
914	O'Ring	24186	2
915	Back-up Ring	24778	1
916	O'Ring	24776	1
917	Back-up Ring	24777	1
918	O'Ring	21123	1
919	Pipe Plug	18009	2
920	Check Spring	25373	1
921	Shim, Valve Spring	25662	1
922	Spring Seat	101015	1

This Page Intentionally Left Blank

This Page Intentionally Left Blank

METRIC CONVERSION TABLE

English to Metric

Metric to English

LINEAR

inches (in.)	X 25.4	= millimeters (mm)	millimeters (mm)	X .03937	= inches (in.)
feet (ft.)	X 0.3048	= meters (m)	meters (m)	X 3.281	= feet (ft.)
miles (mi.)	X 1.6093	= kilometers (km)	kilometers (km)	X 0.6214	= miles (mi.)

AREA

inches ² (sq.in.)	X 645.15	= millimeters ² (mm ²)	millimeters ² (mm ²)	X 0.000155	= inches ² (sq.in.)
feet ² (sq.ft.)	X 0.0929	= meters ² (m ²)	meters ² (m ²)	X 10.764	= feet ² (sq.ft.)

VOLUME

inches ³ (cu.in.)	X 0.01639	= liters (l)	liters (l)	X 61.024	= inches ³ (cu.in.)
quarts (qts.)	X 0.94635	= liters (l)	liters (l)	X 1.0567	= quarts (qts.)
gallons (gal.)	X 3.7854	= liters (l)	liters (l)	X 0.2642	= gallon (gal.)
inches ³ (cu.in.)	X 16.39	= centimeters ³ (cc)	centimeters ³ (cc)	X 0.06102	= inches ³ (cu.in.)
feet ³ (cu.ft.)	X 28.317	= liters (l)	liters (l)	X 0.03531	= feet ³ (cu.ft.)
feet ³ (cu.ft.)	X 0.02832	= meters ³ (m ³)	meters ³ (m ³)	X 35.315	= feet ³ (cu.ft.)
fluid ounce (fl.oz.)	X 29.57	= milliliters (ml)	milliliters (ml)	X 0.03381	= fluid ounce (fl.oz.)

MASS

ounces (oz.)	X 28.35	= grams (g)	grams (g)	X 0.03527	= ounces (oz.)
pounds (lbs.)	X 0.4536	= kilograms (kg)	kilograms (kg)	X 2.2046	= pounds (lbs.)
tons (2000 lbs.)	X 907.18	= kilograms (kg)	kilograms (kg)	X 0.001102	= tons (2000 lbs.)
tons (2000 lbs.)	X 0.90718	= metric tons (t)	metric tons (t)	X 1.1023	= tons (2000 lbs.)
tons (long) (2240 lbs.)	X 1013.05	= kilograms (kg)	kilograms (kg)	X 0.000984	= tons (long) (2240 lbs.)

PRESSURE

inches Hg (60°F)	X 3600	= kilopascals (kPa)	kilopascals (kPa)	X 0.2961	= inches Hg (60°F)
pounds/sq.in. (PSI)	X 6.895	= kilopascals (kPa)	kilopascals (kPa)	X 0.145	= pounds/sq.in. (PSI)
pounds/sq.in. (PSI)	X 0.0703	= kilograms/sq.cm. (kg/cm ²)	kilograms/sq.cm. (kg/cm ²)	X 14.22	= pounds/sq.in. (PSI)
pounds/sq.in. (PSI)	X 0.069	= bars	bars	X 14.5	= pounds/sq.in. (PSI)
inches H ₂ O (60°F)	X 0.2488	= kilopascals (kPa)	kilopascals (kPa)	X 4.0193	= inches H ₂ O (60°F)
bars	X 100	= kilopascals (kPa)	kilopascals (kPa)	X 0.01	= bars

POWER

horsepower (hp)	X 0.746	= kilowatts (kW)	kilowatts (kW)	X 1.34	= horsepower (hp)
ft.-lbs./min.	X 0.0226	= watts (W)	watts (W)	X 44.25	= ft.-lbs./min.

TORQUE

pound-inches (in.-lbs.)	X 0.11298	= newton-meters (N-m)	newton-meters (N-m)	X 8.851	= pound-inches (in.-lbs.)
pound-feet (ft.-lbs.)	X 1.3558	= newton-meters (N-m)	newton-meters (N-m)	X 0.7376	= pound-feet (ft.-lbs.)
pound-feet (ft.-lbs.)	X .1383	= kilograms/meter (kg-m)	kilogram/meter (kg-m)	X 7.233	= pound-feet (ft.-lbs.)

VELOCITY

miles/hour (m/h)	X 0.11298	= kilometers/hour (km/hr)	kilometers/hour (km/hr)	X 0.6214	= miles/hour (m/h)
feet/second (ft./sec.)	X 0.3048	= meter/second (m/s)	meters/second (m/s)	X 3.281	= feet/second (ft./sec.)
feet/minute (ft./min.)	X 0.3048	= meter/minute (m/min)	meters/minute (m/min)	X 3.281	= feet/minute (ft./min.)

TEMPERATURE

$$^{\circ}\text{Celsius} = 0.556 (^{\circ}\text{F} - 32)$$

$$^{\circ}\text{Fahrenheit} = (1.8^{\circ}\text{C}) + 32$$

COMMON METRIC PREFIXES

mega	(M)	= 1,000,000 or 10 ⁶	deci	(d)	= 0.1 or 10 ⁻¹
kilo	(k)	= 1,000 or 10 ³	centi	(c)	= 0.01 or 10 ⁻²
hecto	(h)	= 100 or 10 ²	milli	(m)	= 0.001 or 10 ⁻³
deka	(da)	= 10 or 10 ¹	micro	(μ)	= 0.000.001 or 10 ⁻⁶

LIT2109 R3
February 2020
Printed in USA

PACCAR WINCH
800 E. Dallas Street
Broken Arrow, OK 74012
www.paccarwinch.com

Copyright 2020 PACCAR Inc.
All rights reserved