

---

# BRADEN

---

## HP50B AND HP75A

# HYDRAULIC RECOVERY WINCH

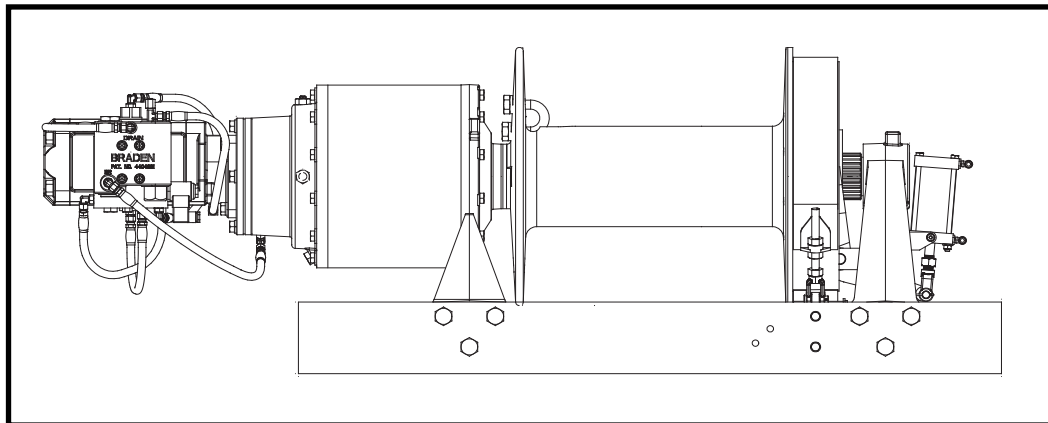

## INSTALLATION, MAINTENANCE AND SERVICE MANUAL



# TABLE OF CONTENTS

FOREWORD .....	4
GENERAL SAFETY RECOMMENDATIONS .....	5
THEORY OF OPERATION.....	6
WINCH INSTALLATION .....	8
HYDRAULIC CIRCUIT .....	10
WIRE ROPE INSTALLATION .....	11
PRE-DELIVERY CHECK LIST .....	12
WINCH OPERATION .....	12
DRUM CLUTCH OPERATION .....	14
AUXILIARY RIGGING .....	17
PREVENTIVE MAINTENANCE.....	18
RECOMMENDED PLANETARY GEAR OIL.....	20
TROUBLESHOOTING .....	21
SERVICE PRECAUTIONS.....	24
RECOMMENDED BOLT TORQUE .....	24
WINCH DISASSEMBLY .....	26
HP50B & HP75A ASSEMBLY.....	28
PLANETARY CARRIER SERVICE.....	30
BRAKE CLUTCH SERVICE.....	32
BRAKE CYLINDER SERVICE .....	35
HP50B & HP75A ROTATION CHANGE .....	37

Safety Informational callouts used in this manual include:

## **WARNING**

**WARNING** – This emblem is used to warn against hazards and unsafe practices which could result in severe personal injury or death if proper procedures are not followed.

## **CAUTION**

**CAUTION** – This emblem is used to warn against potential or unsafe practices which could result in personal injury or product or property damage if proper procedures are not followed.

# FOREWORD

Read and understand this manual before operating or servicing your BRADEN winch. Retain this manual for future reference.

The minimum service intervals specified are for the operating hours of the prime mover.

This manual contains installation, operation and preventive maintenance instructions for most current model BRADEN Planetary Recovery winches. As there are many product variations, you must become familiar with your BRADEN winch to fully benefit from the information contained within this publication.

Some illustrations in this manual may show details or attachments that may be different from your winch, and some components may be removed for illustrative purposes.

Whenever a question arises regarding your BRADEN winch or this manual, please contact your nearest BRADEN distributor or the PACCAR Winch Division Product Support Department at:

Telephone- 1-918-251-8511  
08:00-16:30 Central Time Zone, Monday thru Friday  
FAX- 1-918-259-1575  
[www.paccarwinch.com](http://www.paccarwinch.com)

Provide the complete winch model and serial number when making inquiries.

## Parts and Service

BRADEN provides parts and service through a network of BRADEN distributors. Parts and service are not available directly from the PACCAR Winch Division. For the name of your nearest BRADEN distributor, consult your local phone directory, or contact BRADEN as described above.

## UNIT IDENTIFICATION

When information is needed, always refer to the model number and serial number. Both are located on the top portion of brake cylinder assembly

MODEL NUMBER  
AND  
SERIAL NUMBER

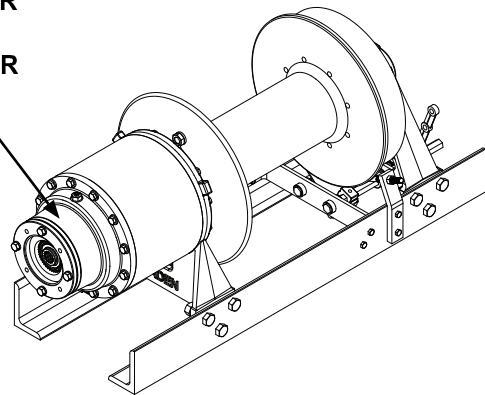

## EXPLANATION OF MODEL NUMBER

**HP 50 B - LP - 104 064 - 01**

HP	DESIGNATES HYDRAULIC PLANETARY
50	DESIGNATES 50,000 POUND FIRST LAYER LINE PULL
B	DESIGNATES THE MODEL SERIES RELATING TO DESIGN CHANGES
LP	DESIGNATES LOW PROFILE
104	DESIGNATES TOTAL GEAR REDUCTION
064	DESIGNATES HYDRAULIC MOTOR DISPLACEMENT (064 - 6.4 CU IN/REV)
01	DESIGNATES THE DRUM OPTION

# GENERAL SAFETY RECOMMENDATIONS

Safety for operators and ground personnel is of prime concern. Always take the necessary precautions to ensure the safety of others as well as yourself. To properly ensure safety, the prime mover and winch **MUST** be operated with care and concern by the operator for the equipment. The operator **MUST** also have a thorough knowledge of the machine's performance capabilities.

## **WARNING**

Failure to obey the following safety recommendations may result in property damage, injury, or death.

1. Read and understand **ALL** warning tag information, and become familiar with **ALL** controls **BEFORE** operating the winch.
2. **NEVER** attempt to clean, oil or perform maintenance on a machine with the engine or prime mover running, unless instructed to do so in this manual.
3. **NEVER** operate the winch controls unless you are properly positioned at the operator's station, you are sure **ALL** personnel are clear of the work area **AND** you are properly trained in the operation of the winch.
4. Assure that personnel who are responsible for hand signals are clearly visible and that the signals to be used are thoroughly understood by all involved.
5. Ground personnel should stay in view of the operator and clear of the winch drum. **DO NOT** allow ground personnel near a winch line under tension. A safe distance of at least 1½ times the length of the outstretched cable should be maintained.
6. On machines having hydraulically, mechanically and/or cable controlled equipment or attachments, ensure the equipment is blocked securely before servicing, adjusting or repairing the winch. **ALWAYS** apply the parking brakes before dismounting a vehicle.
7. Inspect the winch and rigging at the beginning of each work shift. Defects should be corrected immediately. **DO NOT** operate a defective winch.
8. Keep equipment in good operating condition. Perform scheduled service and adjustments as defined in the "Preventive Maintenance" section of this manual.
9. An equipment warm-up procedure is recommended for all start-ups, and is essential at ambient temperatures below +40°F (5°C). Refer to the "Warm-Up Procedure" listed in the "Preventive Maintenance" section of this manual.
10. Check the drum clutch to be certain that the negative draft angle is clearly evident on the clutch and clutch plate. **DO NOT** use the winch if the negative draft angles are worn straight, or if the edges of the clutch plate are rounded or chipped.
11. External clutches on recovery winches may disengage and drop or lose control of a load if they are **NOT** fully engaged at the beginning of a lift or pull. The winch operator must **visually** determine that the clutch is **fully** engaged before lifting or pulling a load.
12. The winches described in this manual are neither designed nor intended for use or application to equipment used in the lifting or moving of persons.
13. **DO NOT** exceed the maximum pressure, PSI (kPa), or flow, GPM (LPM), stated in the winch specifications.
14. Operate the winch at line speeds to match the job conditions.
15. Protective gloves should be worn when handling wire rope.
16. **NEVER** attempt to handle wire rope when the hook end is not free. Keep all parts of body and clothing clear of cable rollers, cable entry area of fairleads and winch cable drum.
17. When winding wire rope on the cable drum, **NEVER** attempt to maintain tension by allowing the wire rope to slip through hands. **ALWAYS** use the "Hand-Over-Hand" technique.
18. **NEVER** use wire rope with broken strands. Replace damaged wire rope.
19. **DO NOT** weld on any part of the winch without approval of PACCAR Winch Division Engineering.
20. Use the recommended hydraulic oil and gear lubricant.
21. Keep the hydraulic system clean and free of contamination at all times.
22. Use the correct anchor for the wire rope and pocket in the drum. **DO NOT** use knots to secure or attach the wire rope to the drum or hook.
23. The cable anchor or ferrule is **NOT** intended to support full rated load. **ALWAYS** maintain a minimum of five (5) wraps on the drum. It is recommended the last five (5) wraps of wire rope be painted bright red to serve as a visual reminder.
24. Install guarding to prevent personnel from getting any part of body or clothing caught at a point where the cable is wrapped onto the drum or drawn through guide rollers or other "pinch points".
25. Install switches or valves that will shut off power to the winch, in locations where they can be reached by anyone entangled in the wire rope before being drawn into the winch drum or other "pinch point".
26. "Deadman" controls, which automatically shut off power to the winch whenever the operator leaves his station, should be installed whenever possible.

27. **NEVER** allow anyone to stand or position any part of his or her body under a suspended load.
28. Avoid sudden “shock” loads, or attempting to “jerk” a load free. This type of operation may cause heavy loads, in excess of rated capacity, which may result in a failure of the wire rope and/or the winch.
29. Whenever possible, install the winch in a location that is not immediately adjacent to a “normal” operator’s station.
30. **ALL** winch controls should be located within easy reach of the operator. The controls shall be installed in such a location that the operator is removed from the electrical path to ground if the load, rigging or wire rope comes into contact with or within proximity to an electrically energized conductor.

## THEORY OF OPERATION

### BASIC DESCRIPTION

The winch consists of the following sub-assemblies:

1. Hydraulic motor and brake valve
2. Planetary gear reducer assembly
3. Static brake system
4. Cable drum, drum shaft and clutch
5. Base

The primary sun gear is directly coupled to the hydraulic motor by the inner race of the brake clutch assembly. As the motor shaft turns in the haul-in direction, the planetary assemblies reduce the speed input by the motor to rotate the cable drum. In the haul-in direction, the static brake remains fully applied and the input shaft rotates freely through the sprag clutch. When the motor is stopped, the load attempts to rotate the winch gear train in the opposite direction locking the brake clutch to the input shaft, allowing the fully applied static brake to hold the load firm.

### DUAL BRAKE SYSTEM

The dual brake system consists of a dynamic brake system and a static brake system.

The dynamic brake system has two operating components:

1. Brake Valve Assembly
2. Hydraulic Motor

The brake valve is basically a counterbalance valve with better metering characteristics for load control. It contains a check valve to allow free oil flow to the motor in the haul-in direction, and a pilot operated, spring-loaded spool valve that blocks the flow of oil out of the motor when the control valve is placed in neutral. With the control valve lever moved toward the pay-out direction, the spool valve

remains closed until sufficient pilot pressure is applied to the end of the spool to shift it against the spring pressure and open a passage. After the spool valve cracks open, the pilot pressure becomes flow dependent and modulates the spool valve opening, controlling the pay-out speed of the winch. See Figures 1, 2, and 3.

The static brake system has three main components for all winches:

1. Spring-Applied, Multiple Friction Disc Static Brake
2. Hydraulic Piston and Cylinder
3. Brake Clutch Assembly

The static brake is released by the brake valve pilot pressure at a pressure lower than that required to open the pilot operated spool valve. This sequence ensures that dynamic braking takes place within the brake valve, and that little, if any, heat is absorbed by the static, friction brake. The static friction brake is load holding brake only, and has nothing to do with dynamic braking or the rate of descent of a load.

The brake clutch assembly is splined to the primary sun gear shaft between the hydraulic motor and primary sun gear. It will allow this shaft to turn freely in the direction to haul-in a load, and locks up to force the brake discs to turn with the shaft in the pay-out direction. See Figures 4 and 5.

The hydraulic brake cylinder, when pressurized, will release the spring pressure on the brake discs, allowing the discs to turn freely.

**Figure 1**

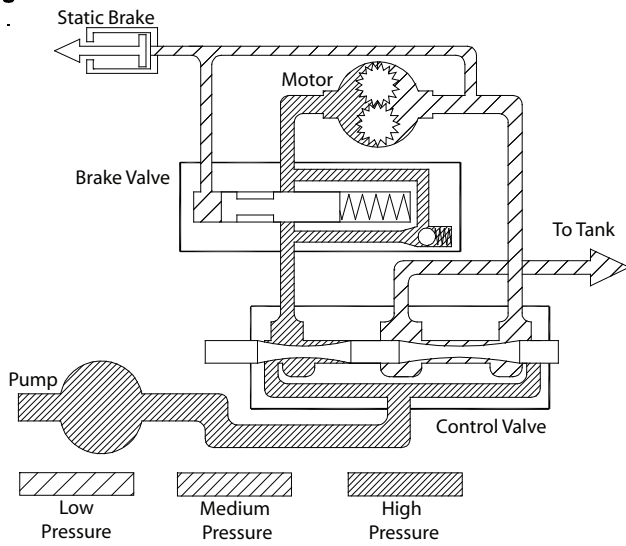

**Figure 4**

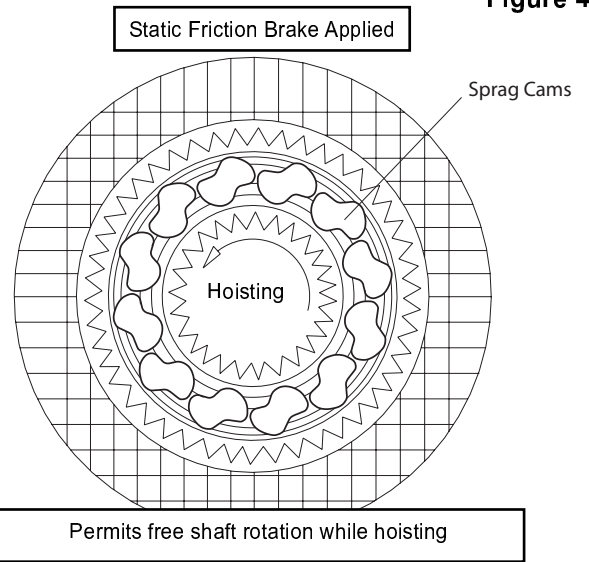

**Figure 2**

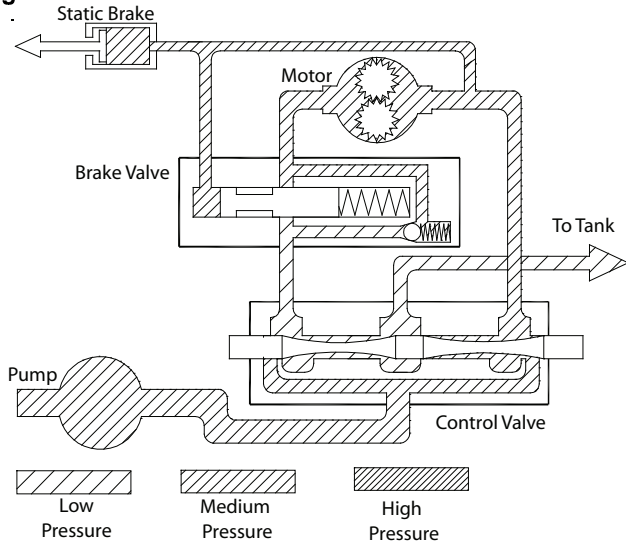

**Figure 5**

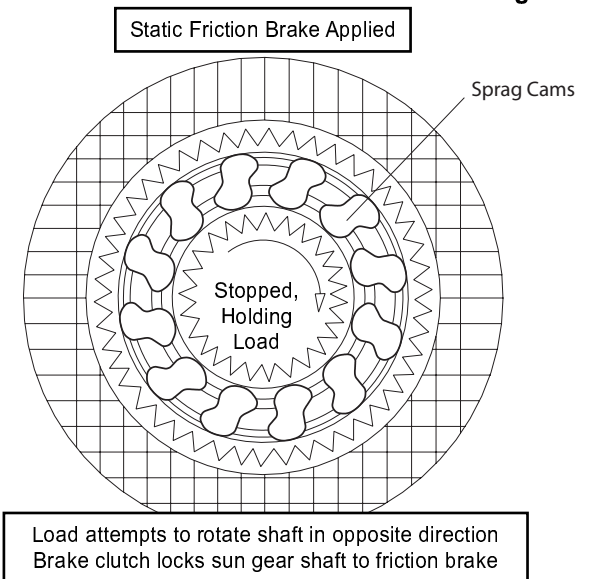

**Figure 3**

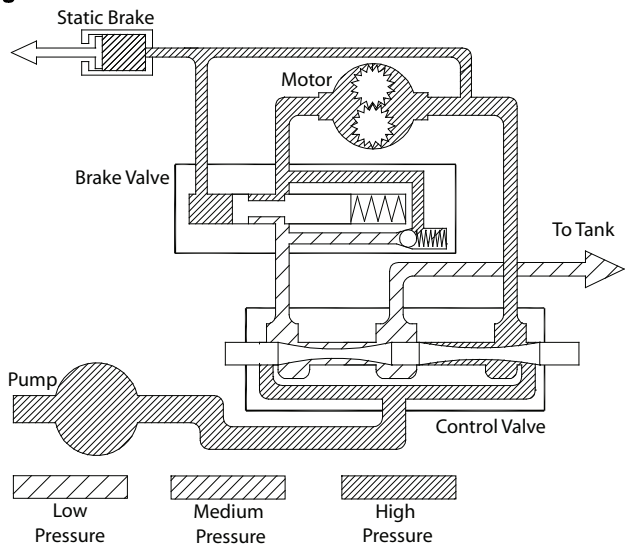

# WINCH INSTALLATION

HP Series winches are configured for bed mount on a truck with the motor end to the passenger side of the vehicle and the wire rope overwound on the drum. Any other installation arrangement will require modifications to the winch before installation.

Headache racks or other protective structures designed to protect the winch, truck, cab, and vehicle occupants should be designed to enable easy access and servicing of the winch. Braden recommends using a structure designed to be easily removed should the need arise to disassemble the winch for servicing.

1. A tank line for the hydraulic motor case drain is required from the shift block tee fitting on the two-speed motor or from the motor case drain port on the single speed motor. Size the tank line so that backpressure in the line is below the limits given in note number six below.

## ⚠ CAUTION ⚠

Failure to install a case drain line will result in a blown out shaft seal on the hydraulic motor and the winch will fill with hydraulic oil.

2. The winch must be mounted to a flat, rigid surface which will not flex under load. The mounting surface must be flat within .020 in. (.05 mm) between mounting fasteners. If necessary, use shim stock to ensure proper mounting.

## ⚠ WARNING ⚠

Flexing or uneven mounting surfaces will produce internal winch distortion which may result in rapid component wear, overheating, poor winch performance or an improperly engaged drum clutch which may become disengaged and result in dropped loads or loss of load control causing property damage, severe injury or death.

3. The centerline of the cable drum must be horizontal and mounted perpendicular to the direction of pull. The fleet angle, or the angle created from an imaginary line from the center of the cable drum to the load or first sheave and from this load point back to the drum barrel intersection with the drum flange, must not exceed  $1\frac{1}{2}^\circ$ . Fleet angles in excess of  $1\frac{1}{2}^\circ$  will create uneven spooling resulting in rapid drum or wire rope wear.
4. Grade 8, or better, fasteners are recommended for mounting fasteners.
5. The winch base angles must be mounted securely to the vehicle frame in a manner acceptable to the vehicle manufacturer. Any frame adapter brackets used should be bolted to the winch base angles as close to the gear

housing and bearing leg assemblies as possible. This will ensure the greatest strength while minimizing distortion. Consult vehicle manufacturer before making any modifications to the vehicle frame.

6. Hydraulic lines and components to operate the winch should be of sufficient size as to minimize the backpressure at the hydraulic motor work ports.

For conventional gear type motors, backpressure at full flow should NOT exceed 100 PSI (690 kPa) for maximum motor shaft seal life. If high backpressures are encountered, the motor case drain can be connected direct to the reservoir. For backpressures in excess of 100 PSI (690 kPa), contact PACCAR Winch Division Technical Support.

Winches equipped with Rineer 2-speed vane type or piston type motors MUST be limited to 35 PSI (240 kPa) backpressure.

7. The winch directional control valve MUST be a three-position, four-way valve without detents and with a spring-centered motor spool, such that the valve returns to the center (Neutral) position whenever the handle is released, and both work ports are opened to tank (open center, open port).

## ⚠ WARNING ⚠

**DO NOT** use a control valve with any detents or latching mechanism that will hold the control valve in an actuated or running position when the operator releases the control lever. Use of the wrong type of control valve could lead to unintentional operation of the winch, which could result in property damage, injury or death.

8. The hydraulic oil filter should have a 10 micron nominal rating and be a full-flow type.
9. High quality hydraulic oil is essential for satisfactory performance and long hydraulic system component life.

Hydraulic oils having a viscosity of 150 – 300 SUS @ 100°F (30 – 56 cSt @ 40°C) and a viscosity index (VI) of 100 or greater will provide good results under normal temperature condition. The use of oil having a high VI will minimize cold start-up problems and reduce the length of warm-up periods. A high VI will also minimize changes in viscosity with corresponding changes in temperature.

**NOTE:** For MAGNUM series winches equipped with Rineer vane type hydraulic motors, the hydraulic oil selected **MUST** remain above 100 SUS @ 100°F (20 cSt @ 40°C) at all operating temperatures.



Maximum cold weather start-up viscosity should not exceed 5000 SUS with a pour point of at least 20°F (11°C) lower than the minimum expected temperature.

Under continuous operating conditions the temperature of the oil at any point in the system should not exceed 180°F (82°C). 120°-140°F (49°-60°C) is generally considered optimum.

In general terms; for continuous operation at ambient temperatures 50°-110°F (10°-43°C), use SAE 20W; for continuous operation at 10°-90°F (-12°-32°C), use SAE 10W; and for applications at ambient temperatures below 10°F (-12°C), contact the PACCAR Winch Division Product Support Department. **NOTE:** *The use of multi-viscosity oils is generally not recommended.*

10. Maximum air pressure of 130 psi for clutch and brake air cylinders.

## TYPICAL HYDRAULIC CIRCUITS

**NOTE:** The hydraulic circuits shown below are representative of typical HP50B/HP75A winches with single and two-speed hydraulic motors and brake valves. Options and accessory equipment may result in changes to the circuits defined. If there are any questions regarding the hydraulic circuit, refer to the information supplied by the original equipment manufacturer, or contact the PACCAR Winch Division Product Support Department, as previously defined. (ALWAYS have the winch model and serial number available when contacting PACCAR Winch Division.)

### Two Speed

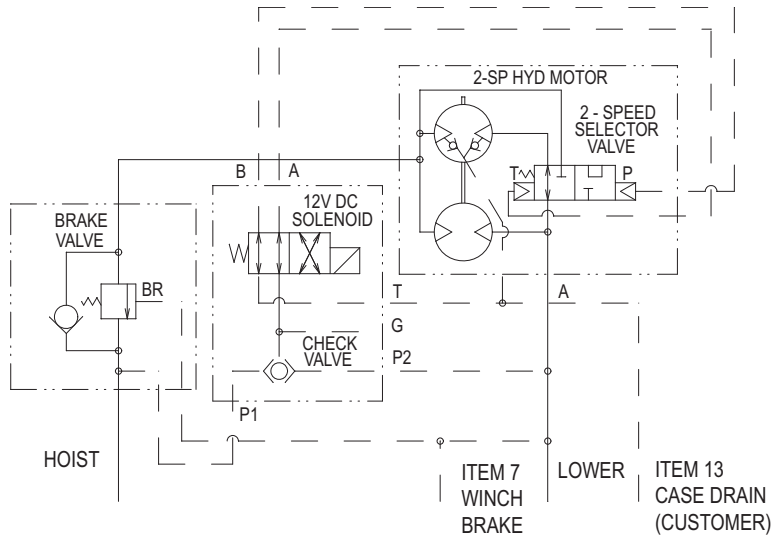

2-Speed Hyd. Motor Sub-Assy Control Circuit  
("A" Port Toward Flange)

### Single Speed

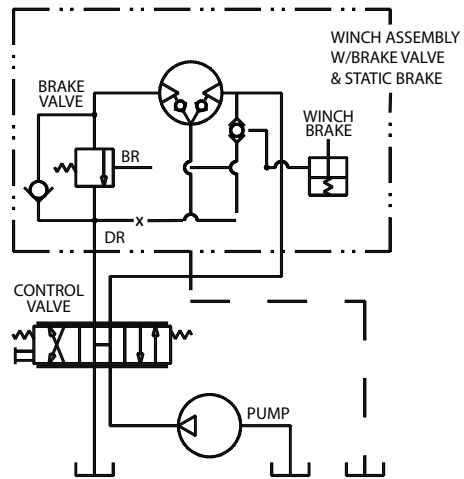

**WINCH CONTROL CIRCUIT  
EXTERNAL CASE DRAIN REQ'D**

#### Electric Shift Circuit

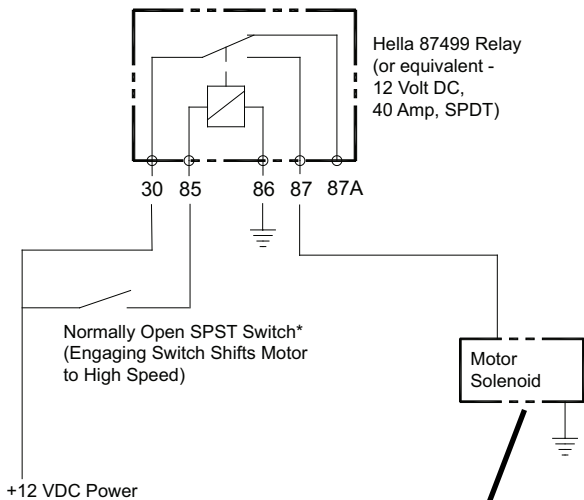

\* DO NOT use a momentary contact switch. This type of switch will return to the open position when released, shifting the motor back to low speed.

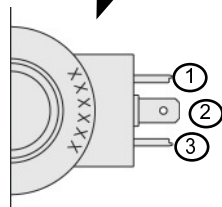

1. Ground
2. Empty
3. Apply 12V DC power to shift motor to High Speed

NOTE:  
Terminals 1 and 3  
may be reversed.

# WIRE ROPE INSTALLATION

Winches are rated at bare drum line pull, meaning the maximum load capability will be reached on the first layer of wire rope. As the cable drum fills, the line pull will decrease (loss of leverage) as the line speed increases (larger circumference). Therefore, it is best to install the minimum length of wire rope possible for your application so the winch will operate on the lowest layers, delivering the maximum load capability.

Use of larger diameter wire rope will not always increase strength as the larger wire rope may be more prone to bending fatigue failure due to the drum diameter. Consult your wire rope supplier for their recommendations regarding the best wire rope and rigging for your application.

## ⚠ WARNING ⚠

Winch wire rope anchors or ferrules are NOT intended to hold rated loads. Winch loads applied directly to the cable anchor may cause the wire rope to pull free and result in sudden loss of load control and cause property damage, injury or death. A minimum of five (5) wraps of wire rope must be left on the drum barrel to achieve rated load.

### INSTALLATION OF U-BOLT TYPE CLAMPS

Prepare the end of the wire rope as recommended by the wire rope manufacturer. Pass the wire rope through the U-bolt until the end extends 1.5 – 2 wire rope diameters beyond the clamp. Evenly tighten the U-bolt nuts until the wire rope deforms slightly under the U-bolt and the wire rope is securely held.

### INSTALLATION OF SPIRAL FERRULES

Re-useable, field installed spiral ferrules are available from PACCAR Winch Division or your wire rope supplier. These ferrules are for use with six (6) strand, IWRC (Independent Wire Rope Core) type wire rope. Refer to cable capacity specifications on page 14.

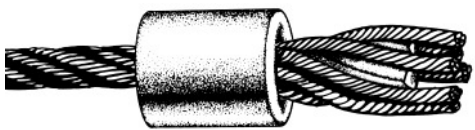

STEP ONE

Insert wire rope through the small diameter end of the ferrule. Spread the strands and insert the spiral wedges between the strands and the core. Lay the strands in the individual grooves in the spiral wedges.

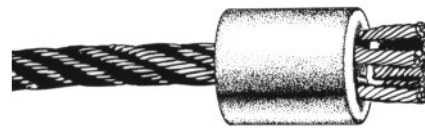

STEP TWO

Tap the wedges and wire rope end into the ferrule, leaving approximately 3/8 in. (10 mm) extending from the top. The first load applied to the winch will seat the wire rope and wedges securely in the ferrule.

# PRE-DELIVERY CHECKLIST

Before releasing the winch to the end user, the following checklist should be reviewed and each item verified.

<b>INSPECTION</b>	
Check gear oil and refill as needed.	
Lubricate all grease fittings.	
Inspect winch mounting fasteners and torque as required.	
Check for loose or missing bolts, pins, keepers and cotter pins. Replace as needed.	
Check controls - adjustment and operation.	
Verify winch operating pressure and flow.	
Verify proper brake band operation.	
Inspect for external oil leaks. Repair as needed.	

## WINCH OPERATION

The following warnings and instructions are basic to safe winch operation. Please read them carefully and follow them any time the winch is in use. These instructions are provided in addition to any information provided by the Original Equipment Manufacturer. Equipment operators should be completely familiar with the overall operation of the vehicle to which the winch is installed. If you have any questions concerning the safe operation of this winch or the equipment to which it is mounted, contact the equipment manufacturer that installed the winch, or the PAC-CAR Winch Division Product Support Department, as previously described.

### **WARNING**

Ground personnel **MUST** stay in view of the operator and clear of the load and cable drum at all times. **DO NOT** allow personnel near the winch line while under tension. **DO NOT** allow personnel near the cable drum during winch operation. **DO NOT** allow personnel to be in line with the load. **DO NOT** allow personnel to stand under a suspended load. A safe distance of 1½ times the working length of the cable should be maintained by ground personnel. A broken wire rope and/or lost load may cause property damage, injury or death.

### **WARNING**

Failure to properly warm up the winch, particularly under low ambient temperature conditions, may result in temporary brake slippage due to high back pressures attempting to release the brake, which may result in property damage, injury or death.

### **WARNING**

Failure to use the proper type and viscosity of planetary gear oil may contribute to intermittent brake clutch slippage which could result in property damage, injury or death. Some gear lubricants contain large amounts of EP (extreme pressure) and anti-friction additives which may contribute to brake slippage and damage to brake friction discs or seals. Oil viscosity with regard to ambient temperature is also critical to reliable brake operation. Testing indicates that excessively heavy or thick gear oil may contribute to intermittent brake slippage. Make certain that the gear oil viscosity used in your winch is correct for your prevailing ambient temperature.

The winch directional control valve, described earlier, controls haul-in and pay-out functions of the winch. Moving the control lever in the haul-in direction will cause the winch to pull in the load toward the vehicle. Moving the control lever in the pay-out direction will cause the winch to feed wire rope off the drum.

Two-speed winches are equipped with a two-speed hydraulic motor and solenoid operated shift valve, eliminating the need to add extra valves to allow two-speed operation. A 12V DC toggle switch is required to actuate the solenoid. The motors are spring-biased to low-speed mode. Actuating the toggle switch will energize the solenoid, allowing pilot pressure to act on the shift spool in the motor, shifting the motor to high-speed mode.

## ⚠ WARNING ⚠

When operating the winch in the pay-out direction, ALWAYS bring the load to a complete stop BEFORE attempting to shift the motor into high speed mode. "Shifting-on-the-fly", or attempting to shift while the load is still moving, will result in pressure intensification between the brake valve and the hydraulic motor, which can damage the motor, brake valve, or other hydraulic components. Failure of these components may cause loss of load control which could lead to personal injury or death.

**NOTE:** *During typical winching operations, it is generally recommended to operate the vehicle engine at high idle RPM and use the winch control valve to control oil flow, and thus winch line speed as needed.*

Position the vehicle such that the centerline of the winch drum is perpendicular to the winch load whenever possible. The wire rope fleet angle must not exceed  $1\frac{1}{2}^\circ$ . If the fleet angle exceeds  $1\frac{1}{2}^\circ$ , the wire rope will not spool correctly eventually resulting in damaged wire rope and prematurely worn winch components.

Either power out the wire rope using the hydraulic system, or disengage the drum clutch and pull the wire rope off the drum by hand (freespool).

## ⚠ WARNING ⚠

The band brake on the clutch end of the cable drum is used to control drum overspin or "birdnesting" ONLY when operating in freespool mode with the drum clutch disengaged. DO NOT attempt to control any winch load using the band brake. Attempting to control or hold any load with the band brake may result in loss of load, property damage, injury or death.

Securely attach the wire rope to the load in such a manner as to avoid damaging the load or rigging. Fully engage the drum clutch (see Drum Clutch Operation).

Ensure the band brake is released and engage the winch control lever. Operate the winch controls smoothly to avoid "jerking" the load and maintain good load control.

Observe the winch operation carefully to make certain all ground personnel remain clear of the wire rope and load, and that the load does not shift, which may require repositioning the wire rope or the vehicle.

Once the load is positioned properly, move the lever back to neutral to stop the winch. Secure the load as required. Pay out just enough wire rope to remove all tension on the cable drum. Disengage the drum clutch and disconnect the wire rope from the load.

Re-engage the drum clutch. Ensure the drum clutch is fully engaged.

Wind the wire rope onto the cable drum while maintaining the minimum fleet angle and sufficient tension to allow the wire rope to spool properly, being careful to keep hands and clothing away from the cable drum and/or fairlead rollers.

# DRUM CLUTCH OPERATION

Visually ensure that the drum clutch is fully engaged and the clutch control lever is at full travel or locked in its detent **BEFORE** attempting to use the winch under load.

## ⚠ WARNING ⚠

**DO NOT** move the load, the winch, or the winch platform **BEFORE** making certain the drum clutch is set to “ENGAGE” and the clutch is fully engaged. A partially engaged drum clutch may “jump out” of engagement. A load on the winch line may prevent a partially engaged clutch from disengaging, but any change in load condition may allow the clutch to become disengaged unexpectedly. This action may cause a loss of load control which could result in property damage, injury or death.

**NOTE:** Actuation of the drum clutch is typically accomplished using either air cylinder controls or some form of mechanical control (i.e. push-pull cable, mechanical linkages, etc.). Any means used to control the drum clutch must allow full travel of the lever without binding the clutch, or should include locking detents at each position.

### To ENGAGE the drum clutch:

1. Insure the winch motor is stopped and there is no load on the wire rope. The prime mover must be stopped in neutral and the parking brake must be set.
2. Move the clutch control lever fully into the “Engage” position. If the lever will not settle into the fully engaged position, the clutch is not fully engaged. At this point, it may be necessary to MANUALLY rotate the cable drum slightly in either direction to align the clutch lugs, while continuing to hold slight pressure on the control lever. Once the clutch lugs are properly aligned, the clutch should easily engage fully with the clutch plate on the cable drum.

### To DISENGAGE the drum clutch:

1. Insure the winch motor is stopped and there is no load on the wire rope. The prime mover must be stopped in neutral and the parking brake must be set.
2. Move the control lever fully into the “Disengage” position. If the control lever has any resistance to shift, the cable drum may be MANUALLY rotated in the direction to haul-in wire rope to relieve the self-energized load on the clutch lugs and allow the clutch to properly disengage.

## ⚠ WARNING ⚠

**DO NOT** attempt to engage the drum clutch while the cable drum is rotating. **DO NOT** attempt to disengage the drum clutch with a load applied to the wire rope. **DO NOT** use “cheaters” to extend the shift lever length or other means to apply undue force on the lever. Engaging or disengaging the drum clutch while the cable drum is rotating or under load, or the use of undue force, may result in damage to the drum clutch components. Damaged drum clutch components may allow the drum clutch to become disengaged under load, and cause a loss of load control, which could result in property damage, injury or death.

**NOTE:** If your application involves lifting loads and does not require the clutch to be disengaged, it is strongly recommended that the drum clutch be mechanically blocked in the fully engaged position to avoid accidental disengagement of the clutch under load.

## ⚠ WARNING ⚠

Accidental disengagement of the clutch while lifting or lowering may cause a loss of load control, which could lead to property damage, injury or death.

## PROCEDURE FOR DETERMINING THE CONDITION OF CLUTCH LUGS:

There is normally a “negative draft” angle on the load bearing faces of the clutch and clutch plate to prevent clutch disengagement under load. In addition to visual inspection of the clutch surfaces, the following procedure may be used to ensure that the clutch cannot inadvertently disengage under load:

1. Fully engage the clutch (as previously described).
2. Power approximately 10 ft. (3 m) of wire rope off the drum.
3. Power in very slowly while holding slight pressure on the wire rope to eliminate any slack in the wire rope and the power train. This slight pressure and no-slack condition must be maintained throughout this procedure.
4. Stop the winch with the clutch fully engaged, leaving approximately 3 ft. (1 m) of wire rope extended beyond the drum.
5. Mark one line on or near the tip of the drum flange nearest the gear housing, and a second line on the gear housing adjacent to the first.
6. While maintaining tension on the wire rope, SLOWLY disengage the drum clutch and observe the marked lines. The drum flange should move 1/16 – 5/16 in. (1.5 – 8 mm) in the haul-in direction. If the drum moves LESS than 1/16 in. (1.5 mm), or if the drum rotates in the opposite direction, the winch should be disassembled and the clutch components visually inspected for wear and/or damage and replaced as needed. The drum clutch should be routinely inspected using this procedure.

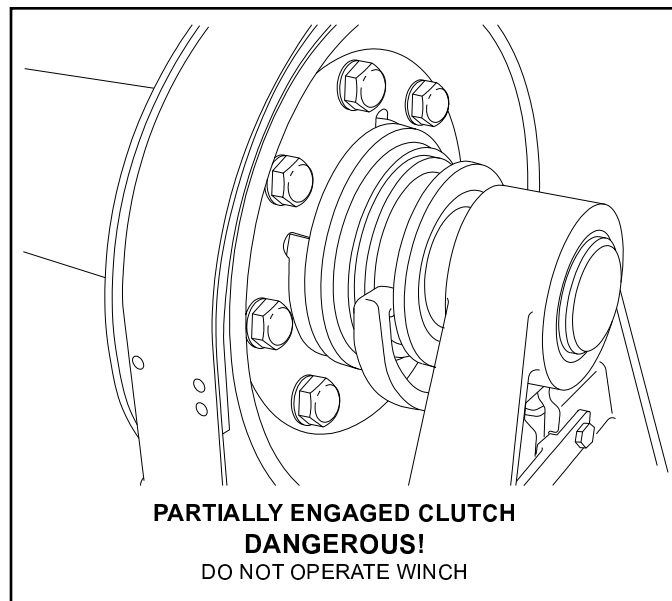
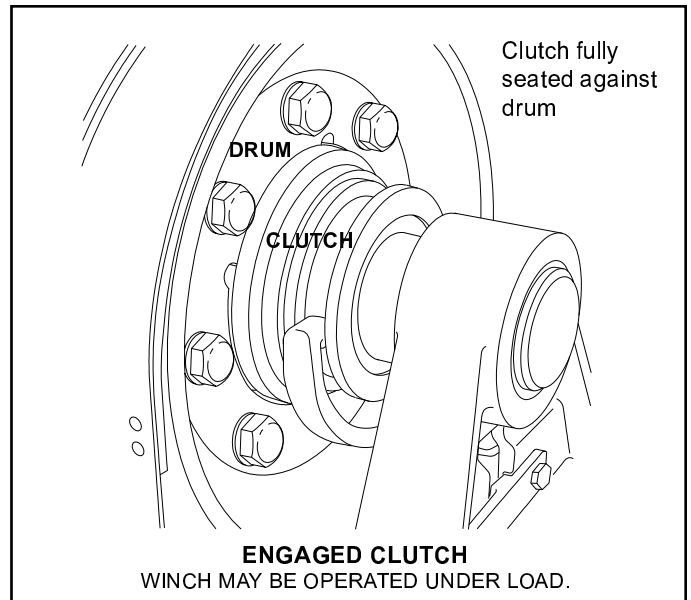
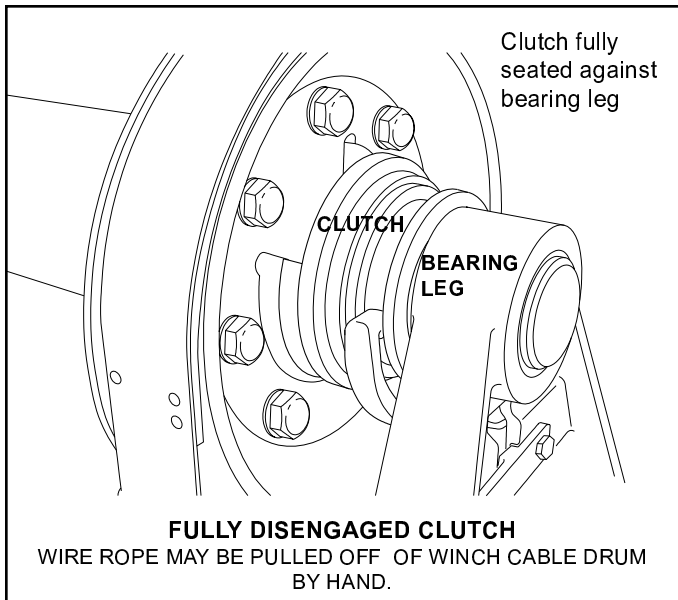

## WINCH DRUM CLUTCH CONTROL

### ⚠ WARNING ⚠

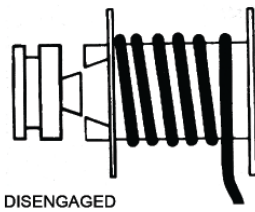

- **DO NOT** move the load or the winch platform, or operate the winch before making certain the drum clutch is set to “engage” and the clutch is fully engaged.

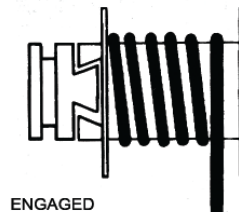

A load on the winch line may prevent a partially-engaged clutch from disengaging, but any change in the load may allow the clutch to disengage unexpectedly. This could result in loss of load control, property damage, injury, or death.

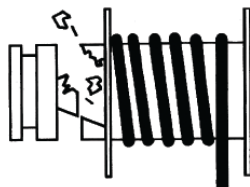

- **DO NOT** attempt to engage drum clutch while cable drum is rotating.
- **DO NOT** attempt to disengage drum clutch with a load applied to the winch cable.

Engaging or disengaging the drum clutch while the cable drum is rotating or under load may result in damage to drum clutch components. Damaged drum clutch components may disengage under load, which could result in loss of load control, property damage, injury, or death.

Refer to the appropriate BRADEN maintenance publication for more information.

Install this label near winch controls.



PN 100600

The Warning Label shown above is available through all Braden dealers. Have your dealer order part number 100600. It is a self-adhesive weather-resistant vinyl label that we recommend be installed near the winch controls of all Braden winches with a drum clutch.



# AUXILIARY RIGGING

## Snatch Block

An auxiliary sheave, or snatch block, may increase the versatility of the winch, and is highly recommended in the following applications:

- When fleet angles exceed  $1\frac{1}{2}^\circ$ .
- When winch loads exceed the safe winch or wire rope capacity.
- When slower line speeds are required for precise load control.

Securely attach the snatch block to the anchor point following the block manufacturer's recommendations.

## Tree Protector

If the wire rope or a snatch block must be anchored to a tree or other structure for recovery purposes, a heavy nylon web sling of proper capacity rating should be used to avoid causing serious damage to the tree.

**⚠ WARNING ⚠**

A poorly attached or undersized snatch block may break loose from the anchor point and cause a sudden loss of load control, which may result in property damage, injury or death.

### HP50B

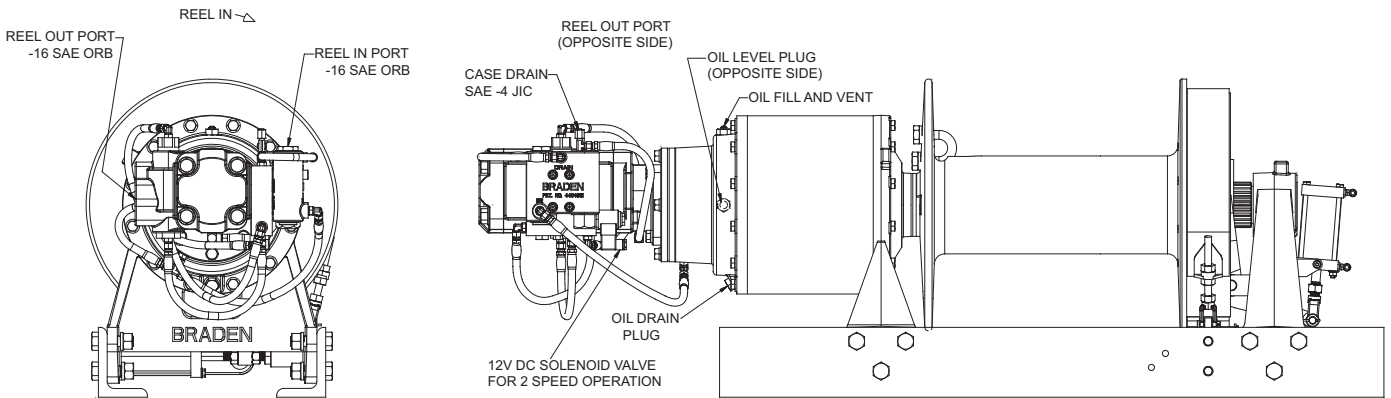

### HP75A

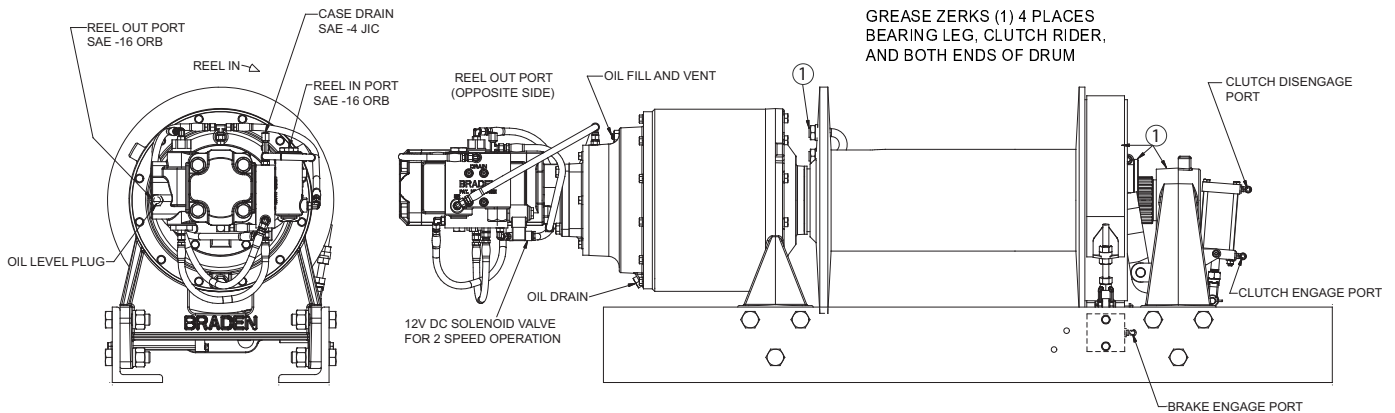

#### NOTES:

1. HP50B oil capacity: 7 pints  
HP75A oil capacity: 11 pints
2. Keep a minimum of 5 wraps of rope on the drum at all times to assist the anchor in holding the load.
3. Maximum air pressure of 130 psi for clutch & brake cylinder.

# PREVENTIVE MAINTENANCE

A regular program of preventive maintenance for your winch is required to minimize the need for emergency servicing and will promote safe, reliable winch operation.

The user of PACCAR Winch products is responsible for winch inspection, testing, operator training and the maintenance noted below, with frequency dependent on the severity of the winch duty cycle and the thoroughness of the preventive maintenance program.

Field experience, supported by engineering testing, indicate the two service procedures listed below are the most critical to safe, reliable winch operation and **MUST** be observed.

- Regular Gear Oil Changes
- Use of Proper Gear Oil – recommended type for prevailing ambient temperatures and additives.

## ⚠ WARNING ⚠

**NEVER** attempt to service a winch with the prime mover running as accidental engagement may result in property damage, injury or death. Make certain **ALL** load is removed from the wire rope and winch cable drum **BEFORE** servicing the winch. A loaded wire rope may rapidly and unexpectedly unspool, resulting in property damage, injury or death.

### Recommended Preventive Maintenance Intervals:

#### Daily (when winch is in use)

1. Inspect the wire rope and rigging for broken wires or other damage, as recommended by the wire rope and rigging manufacturer(s).
2. Carefully inspect the drum clutch and adjust the shift mechanism as required to ensure the clutch can be fully engaged and disengaged. (Refer to “Drum Clutch Operation”.)
3. Check for external oil leaks – both hydraulic and gear oil – and repair as required. This is extremely important due to the accelerated wear that can be caused by insufficient lubrication within the winch. Gear oil must be maintained at the proper level. Use only recommended lubricants. (See “Recommended Lubricants” in this manual.)
4. Check hydraulic motor plumbing for damage, such as chafed or deteriorating hoses, and repair as needed.
5. Visually inspect for loose or missing bolts, pins, keepers or cotter pins, and tighten or replace as needed.

#### Weekly

1. Perform all daily inspections.
2. Check gear oil level, and refill as needed with the recommended lubricant.

3. Lubricate the grease fittings on the bearing leg, cable drum ends and clutch. On some winches, you will have to disengage the clutch to gain access to the drum bushing grease fitting on the clutch end of the drum. Use a high-quality, moly-type grease, with a rating of NLGI-2 or better.
4. Inspect the gear housing breather to ensure the fitting is not clogged with dirt or grease. Clean or replace as needed.
5. Inspect all winch mounting fasteners. Retighten or replace as required.
6. Inspect any structural welds, and repair as needed.

#### Monthly

1. Perform all daily and weekly inspections.
2. Inspect the drum clutch and clutch plate to ensure the negative draft angle is clearly evident. Replace worn clutch components as required. (Refer to “Drum Clutch Operation” in this manual.)

## ⚠ WARNING ⚠

**DO NOT** use the winch if the negative draft angle on the clutch is not present or is worn straight, or if the clutch plate edges are rounded or chipped. A defective drum clutch may suddenly become disengaged causing a loss of load control, which may result in property damage, injury or death.

3. Check the hydraulic system relief valve setting to ensure proper performance and protection of hydraulic components. Adjust or repair as required.
4. Inspect hydraulic system filters and strainers. Follow the system manufacturer’s service recommendations for repair or replacement.
5. Inspect the band brake for wear or chipping away of the brake lining material. Adjust or replace as needed.

#### Yearly

1. Perform all daily, weekly and monthly inspections.
2. Replace gear oil.

**NOTE:** *If the winch is used in excess of 40 hours per week, the gear oil should be changed every 6 months.*

## ⚠ WARNING ⚠

Hot oil can cause severe injury. Make certain the oil has cooled to a safe temperature before servicing.

Inspection Performed	Inspection Interval			
	Daily	Weekly	Monthly	Yearly
Inspect wire rope and rigging	X	X	X	X
Inspect drum clutch and shift mechanism for proper engagement	X	X	X	X
Inspect for external oil leaks	X	X	X	X
Check for damaged hoses / lines	X	X	X	X
Check for loose or missing bolts, pins, keepers, or cotter pins	X	X	X	X
Check gear oil level / refill		X	X	X
Lubricate grease fittings		X	X	X
Inspect breather fitting		X	X	X
Inspect winch mounting fasteners - torque as required		X	X	X
Inspect structural welds		X	X	X
Inspect negative draft angle on drum clutch and clutch plate			X	X
Check hydraulic relief valve setting			X	X
Inspect hydraulic filters / strainers			X	X
Inspect band brake			X	X
Replace gear oil <sup>(1) (2)</sup>				X

**NOTES:**

- (1) Change the gear oil after the first 100 hours or 30 days of use, whichever occurs first.
- (2) For winch operation in excess of 40 hours per week, oil changes should occur every 6 months instead of yearly.

## SPECIFICATIONS

	HP50A	HP50B 7.7/3.8 Motor	HP50B 8.0/4.0 Motor	HP70A	HP75A 8.9/4.5 Motor	HP75A 13.0/6.5 Motor	HP125A	HP125B	HP160A
<b>Rated Bare Drum Line Pull</b>	50,000 Lb (22,680 kg)	50,000 Lb (22,680 kg)	50,000 Lb (22,680 kg)	70,000 Lb (31,750 kg)	75,000 Lb (34,110 kg)	75,000 Lb (34,110 kg)	125,000 Lb (56,700 kg)	125,000 Lb (56,700 kg)	160,000 Lb (72,580 kg)
<b>Bare Drum Line Speed - Single Speed</b>	41 fpm (12 mpm)			57 fpm (17 mpm)					
<b>Bare Drum Line Speed - Low Speed</b>	23 fpm (7 mpm)	31 fpm (9 mpm)	26 fpm (8 mpm)	24 fpm (7 mpm)	26 fpm (8 mpm)	27 fpm (8 mpm)	21 fpm (6 mpm)	21 fpm (6 mpm)	14 fpm (4 mpm)
<b>- High Speed</b>	53 fpm (16 mpm)	62 fpm (19 mpm)	53 fpm (16 mpm)	55 fpm (17 mpm)	55 fpm (17 mpm)	54 fpm (16 mpm)	47 fpm (14 mpm)	47 fpm (14 mpm)	29 fpm (9 mpm)
<b>Wire Rope Capacity - <sup>3</sup>/<sub>4</sub>" (20 mm)</b>	480 ft (146 m)	480 ft (146 m)	480 ft (146 m)						
<b>- <sup>7</sup>/<sub>8</sub>" (22 mm)</b>	350 ft (106 m)	350 ft (106 m)	350 ft (106 m)	327 ft (99 m)	327 ft (99 m)	327 ft (99 m)			
<b>- 1" (25 mm)</b>	250 ft (76 m)	250 ft (76 m)	250 ft (76 m)	226 ft (69 m)	226 ft (69 m)	226 ft (69 m)	327 ft (99 m)	327 ft (99 m)	
<b>- 1<sup>1</sup>/<sub>8</sub>" (29 mm)</b>				209 ft (55 m)	209 ft (63 m)	209 ft (63 m)	224 ft (68 m)	224 ft (68 m)	
<b>- 1<sup>1</sup>/<sub>4</sub>" (32 mm)</b>							209 ft (63 m)	209 ft (63 m)	390 ft (118 m)
<b>- 1<sup>3</sup>/<sub>8</sub>" (35 mm)</b>									365 ft (110 m)
<b>- 1<sup>1</sup>/<sub>2</sub>" (38 mm)</b>									256 ft (80 m)
<b>Overall Gear Ratio</b>	98:1	104:1	104:1	81:1	122:1	88:1	156:1	156:1	206:1
<b>Maximum Pressure - Single Speed Motor</b>	2700 PSI (18,600 kPa)			2800 PSI (19,300 kPa)					
<b>- 2-Speed Motor</b>	2700 PSI (18,600 kPa)	2400 PSI (16,548 kPa)	2000 PSI (13,790 kPa)	2600 PSI (17,900 kPa)	2670 PSI (18,410 kPa)	2400 PSI (16,548 kPa)	2600 PSI (17,900 kPa)	2600 PSI (17,900 kPa)	2500 PSI (17,200 kPa)
<b>Maximum Flow - Single Speed Motor</b>	60 GPM (227 LPM)			110 GPM (416 LPM)					
<b>- 2-Speed Motor</b>	40 GPM (151 LPM)	60 GPM (227 LPM)	50 GPM (190 LPM)	60 GPM (227 LPM)	60 GPM (227 LPM)	60 GPM (227 LPM)	85 GPM (322 LPM)	85 GPM (322 LPM)	65 GPM (246 LPM)
<b>Winch Weight - Single Speed Motor</b>	1,040 LB (472 kg)			1,475 LB (670 kg)					
<b>- 2-Speed Motor</b>	1,075 LB (488 kg)	990 LB (450 kg)	990 LB (450 kg)	1,500 LB (680 kg)	1,340 LB (608 kg)	1,340 LB (608 kg)	1,800 LB (817 kg)	1,785 LB (810 kg)	3,850 LB (1746 kg)
<b>Gearbox Oil Capacity (pints)</b>	14 (6.6 L)	8 (3.7 L)	8 (3.7 L)	20 (9.5 L)	11 (5.2 L)	11 (5.2 L)	12.5 (5.9 L)	12.5 (5.9 L)	28 (13.3 L)

## RECOMMENDED PLANETARY GEAR OIL

Field experience, supported by engineering endurance tests, indicates the use of the proper gear oil and a program of regular preventive maintenance will help provide extended gear train life and reliable winch brake performance. For this reason, BRADEN has published the following specifications to assist in determining which lubricant is best suited to your application.

### ⚠ WARNING ⚠

Failure to use the proper type and viscosity of planetary gear oil may contribute to intermittent brake clutch slippage which could result in property damage, severe personal injury or death. Some gear lubricants contain large amounts of EP (extreme pressure) and anti-friction additives which may contribute to brake clutch slippage or damage to brake friction discs or seals. Oil viscosity with regard to ambient temperature is also critical to reliable brake clutch operation. Our tests indicate that excessively heavy or thick gear oil may contribute to intermittent brake clutch slippage. Make certain that the gear oil viscosity used in your winch is correct for your prevailing ambient temperature.

For simplicity, BRADEN has listed available products in each temperature range that have been tested and found to meet our specifications. This is not to say that other lubricant brands would not perform equally as well.

If the following lubricant brands are not available in your area, make certain your lubricant vendor supplies you with oil that is equivalent to those products listed below.

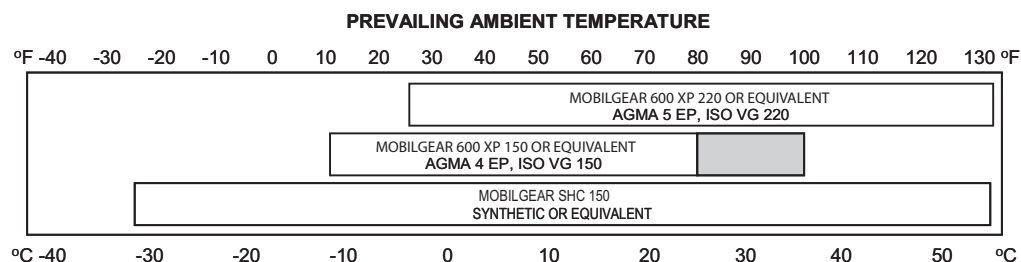

**i** NOTE: SHADED TEMPERATURE RANGE IN THE CHART ABOVE NOT RECOMMENDED FOR SEVERE APPLICATIONS SUCH AS: OFFSHORE CRANES, SUSTAINED FAST DUTY CYCLES OR FREQUENT LIFTING.

Planetary hoists are factory filled with Mobilgear 600 XP 150, or equivalent. Consult your oil supplier for other equivalent oils if required.

Mobil	Shell	Chevron	Texaco
Mobilgear 600 XP 150	Omala 150	Gear Compounds EP 150	Meropa 150
Mobilgear 600 XP 220	Omala 220	Gear Compounds EP 220	Meropa 220

Unless otherwise specified, it is recommended that the gear oil be changed after the first one hundred (100) hours or thirty (30) days of machine operation, then every one thousand (1,000) hours or twelve (12) months, whichever occurs first. The gear oil should also be changed whenever the ambient temperature changes significantly and an oil from a different temperature range would be more appropriate.

A warm-up procedure is recommended at each start-up and is essential at ambient temperatures below +40°F (4°C).

The prime mover should be run at its lowest recommended RPM with the hydraulic winch control valve in neutral allowing sufficient time to warm up the system. The winch should then be operated at low speeds, forward and reverse, several times to prime all lines with warm hydraulic oil and to circulate gear lubricant through the planetary gear sets.

### ⚠ WARNING ⚠

Failure to properly warm up the winch, particularly under low ambient temperature conditions, may result in temporary brake slippage due to high back pressures attempting to release the brake, which could result in property damage, severe personal injury or death.

If you have any questions regarding this bulletin or your BRADEN planetary winch, please contact the BRADEN Product Support Department at 1-918-251-8511, Monday through Friday from 08:00 to 16:30 hours CST, or by fax at 1-918-259-1575.

# TROUBLESHOOTING

TROUBLE	PROBABLE CAUSE	REMEDY
<b>A</b>  The winch will not lower the load or not lower the load smoothly.	<p>1. The problem could be a plugged or loose pilot orifice. The pilot orifice is a small pipe plug with a hole drilled through it, located behind the pilot port fitting on the brake valve. If it becomes plugged, it will prevent the pilot pressure, from the manifold, from opening the brake valve. If it becomes loose, it will allow an unregulated amount of oil in to operate the brake valve which causes erratic brake valve operation.</p> <p>2. The friction brake may not be releasing as a result of a defective brake cylinder seal.</p> <p><b>NOTE:</b> <i>If the brake cylinder seal is defective you will usually find oil leaking from the winch vent plug.</i></p> <p>3. Friction brake will not release as a result of damaged brake discs.</p>	<p>Remove the pilot hose and fitting from the brake valve, then use a 5/32 inch Allen wrench to remove the pilot orifice. The diameter of the orifice is approximately .020 inches. Clean and install the pilot orifice tightly in the brake valve.</p> <p>Check brake cylinder seal as follows:</p> <p>A. Disconnect the swivel tee from the brake release port. Connect a hand pump with accurate 0-2000 psi gauge and shut-off valve to the -4 J.I.C. fitting in the brake release port.</p> <p>B. Apply 1000 psi to the brake. Close shut-off valve and let stand for five (5) minutes.</p> <p>C. If there is any loss of pressure in five (5) minutes, the brake cylinder should be disassembled for inspection of the sealing surfaces and replacement of the seals. Refer to "Motor Support-Brake Cylinder Service".</p> <p>Disassemble brake to inspect brake discs. Check stack-up height as described in "Motor Support-Brake Cylinder Service".</p>
<b>B</b>  Oil leaks from vent plug.	<p>1. Same as A2.</p> <p>2. Motor seal may be defective as a result of high system back pressure or contaminated oil.</p>	<p>Same as A2.</p> <p>System back pressure must not exceed 150 psi. Inspect hydraulic system for a restriction in the return line from the control valve to the reservoir. Be sure control valve and plumbing is properly sized to winch motor. Ensure case drain line is connected and adequate size.</p> <p>Oil analysis may indicate contamination has worn motor shaft and seal. Thoroughly flush entire hydraulic system and install new filters and oil. Install new motor seal.</p>

TROUBLE	PROBABLE CAUSE	REMEDY
<p style="text-align: center;"><b>C</b></p> <p>The brake will not hold a load with the control lever in neutral.</p>	<ol style="list-style-type: none"> <li>1. Excessive system back pressure acting on the brake release port.</li> <li>2. Friction brake will not hold due to worn or damaged brake discs.</li> <li>3. Brake clutch is slipping.</li> </ol>	<p>The same as Remedy 2 of Trouble B2.</p> <p>Same as Remedy 3 of Trouble A3.</p> <p>Improper planetary gear oil may cause the brake clutch to slip. Drain old gear oil and flush winch with solvent. Thoroughly drain solvent and refill winch with recommended planetary gear oil listed in "Preventive Maintenance".</p> <p>Brake clutch may be damaged or worn. Disassemble and inspect brake clutch as described in "Brake Clutch Service".</p>
<p style="text-align: center;"><b>D</b></p> <p>The winch will not hoist the rated load.</p>	<ol style="list-style-type: none"> <li>1. The winch may be mounted on an uneven or flexible surface which causes distortion of the winch base and binding of the gear train. Binding in the gear train will absorb horsepower needed to hoist the rated load and cause heat.</li> <li>2. System relief valve may be set too low. Relief valve needs adjustment or repair</li> <li>3. Be certain hydraulic system temperature is not more than 180 degrees F. Excessive hydraulic oil temperatures increase motor internal leakage and reduce motor performance.</li> <li>4. Winch line pull rating is based on 1st layer of wire rope.</li> <li>5. Rigging and sheaves not operating efficiently.</li> </ol>	<p>Reinforce mounting surface.</p> <p>If necessary, use shim stock to level winch. Refer to "Winch Installation".</p> <p>First loosen, then evenly retighten all winch mounting bolts to recommended torque.</p> <p>Check relief pressure as follows:</p> <p>A. Install an accurate 0-4000 psi (27,580 kPa) gauge into the inlet port of the brake valve.</p> <p>B. Apply a stall pull load on the winch while monitoring pressure.</p> <p>C. Compare gauge reading to winch specifications. Adjust relief valve as required.</p> <p>NOTE: If pressure does not increase in proportion to adjustment, relief valve may be contaminated or worn out. In either case, the relief valve may require disassembly or replacement.</p> <p>Refer to winch performance charts for additional information.</p> <p>Perform rigging service as recommended by crane manufacturer.</p>

TROUBLE	PROBABLE CAUSE	REMEDY
<p style="text-align: center;"><b>E</b></p> <p>The winch runs hot.</p>	<ol style="list-style-type: none"> <li>1. Same as D1.</li> <li>2. Be certain that the hydraulic system temperature is not more than 180 degrees F. Excessive hydraulic oil temperatures may be caused by:               <ol style="list-style-type: none"> <li>A. Plugged heat exchanger.</li> <li>B. Too low or too high oil level in hydraulic reservoir.</li> <li>C. Same as D2.</li> <li>D. Hydraulic pump not operating efficiently.</li> </ol> </li> <li>3. Excessively worn or damaged internal winch parts.</li> </ol>	<p>Same as remedies for Trouble D1.</p> <p>Thoroughly clean exterior and flush interior.</p> <p>Fill/drain to proper level.</p> <p>Same as remedies for Trouble D2.</p> <p>Prime mover low on horsepower or R.P.M. Tune/adjust prime mover.</p> <p>Check suction line for damage.</p> <p>If pump is belt driven, belts are slipping. Replace/tighten belts.</p> <p>Pump worn. Replace pump.</p> <p>Disassemble winch to inspect/replace worn parts.</p>
<p style="text-align: center;"><b>F</b></p> <p>Winch "chatters" while raising rated load.</p>	<ol style="list-style-type: none"> <li>1. Same as D2.</li> <li>2. Hydraulic oil flow to motor may be too low.</li> <li>3. Controls being operated too quickly.</li> </ol>	<p>Same as remedies for Trouble D2.</p> <p>Same as remedies for Trouble E2.</p> <p>Conduct operator training as required.</p>

# SERVICE PRECAUTIONS

## HP50B/HP75A UPPER LEVEL DISASSEMBLY

Before any part is removed from the hoist or drive gearbox, all service instructions should be read and understood.

Work in a clean, dust free area as cleanliness is of utmost importance when servicing hydraulic equipment.

Inspect all replacement parts, prior to installation, to detect any damage which might have occurred in shipment.

Use only genuine BRADEN replacement parts for optimum results. Never re-use expendable parts such as o-rings and oil seals.

Inspect all machined surfaces for excessive wear or damage before reassembly operations are begun.

Lubricate all o-rings and oil seals with gear oil prior to installation.

Lubricate all bearings with oil soluble grease prior to assembly.

Use a sealing compound on the outside surface of oil seals and a light coat of thread sealing compound on pipe threads. Avoid getting sealing compound inside parts or passages which conduct oil.

Before starting disassembly of the winch, remove the wire rope, drain the oil and clean the outside surfaces to avoid contaminating gears and bearings.

## RECOMMENDED BOLT TORQUE

The general purpose torque shown in the chart applies to SAE Grade 5 & Grade 8 bolts, studs and standard steel full, thick and high nuts.

Higher or lower torques for special applications will be specified such as the use of spanner nuts, nuts on shaft ends, jam nuts and where distortion of parts or gaskets is critical.

Lubricated torque values based on use of SAE 30 engine oil applied to threads and face of bolt or nut.

Bolt Diam. Inches	Thread per inch	Torque LB-FT (N.m)			
		Grade 5		Grade 8	
		Dry	Lubed	Dry	Lubed
1/4	20	8	6	12	9
	28	(11)	(8)	(16)	(12)
5/16	18	17	13	24	18
	24	(23)	(17)	(33)	(24)
3/8	16	31	23	45	35
	24	(42)	(31)	(61)	(47)
7/16	14	50	35	70	50
	20	(68)	(47)	(95)	(68)
1/2	13	75	55	110	80
	20	(102)	(75)	(149)	(108)
9/16	12	110	80	150	110
	18	(149)	(108)	(203)	(149)
5/8	11	150	115	210	160
	18	(203)	(156)	(285)	(217)

Bolt Diam. Inches	Thread per inch	Torque LB-FT (N.m)			
		Grade 5		Grade 8	
		Dry	Lubed	Dry	Lubed
3/4	10	265	200	380	280
	16	(359)	(271)	(515)	(380)
7/8	9	420	325	600	450
	14	(569)	(441)	(813)	(610)
1	8	640	485	910	680
	14	(868)	(658)	(1234)	(922)
1 1/8	7	790	590	1290	970
	12	(1071)	(800)	(1749)	(1315)
1 1/4	7	1120	835	1820	1360
	12	(1518)	(1132)	(2468)	(1817)
1 3/8	6	1460	1095	2385	1790
	12	(1979)	(1485)	(3234)	(2427)
1 1/2	6	1940	1460	3160	2370
	12	(2360)	(1979)	(4284)	(3214)

To convert LB-FT to Kg-m, multiply LB-FT value by 0.1383

8-2008



**THIS PAGE INTENTIONALLY LEFT BLANK**



## DISASSEMBLY

### **⚠ WARNING ⚠**

The HP50B winch weighs approximately 1000 lbs (454 kg); the HP75A weighs approximately 1350 lbs (612 kg). Ensure all lifting equipment including the overhead hoist and rigging have adequate capacity. Use of lifting equipment that does not have adequate lifting capacity or is not properly maintained may result in personal injury or death.

1. Remove the wire rope from the winch and drain the gear oil from the winch by removing the drain plug on the bottom of the winch gearbox. Remove the fill/vent plug to speed draining.
2. Take precautions to collect hydraulic oil and remove the hydraulic hoses connected to the winch motor and disconnect the brake release hose from the winch brake release port. Ensure there are no external hose connections to the winch motor then remove the motor by removing the four capscrews securing it to the winch.
3. Remove the overrunning clutch assembly (100) from the brake cylinder assembly (200).
4. The remaining disassembly is most easily done with the winch standing on the support end. Blocks should be placed under the support end bearing leg so that the winch rests level on the base angles on one side and blocks under the bearing leg on the other side.

### **⚠ CAUTION ⚠**

If the winch cannot be set on the support end, but must be serviced with the winch on the base angles, remove the brake cylinder assembly slowly and carefully. The primary planet carrier (300), primary sun gear (58), thrust washers (56 and 57), and secondary sun gear (59) can fall between the brake cylinder and the ring gear as the brake cylinder is removed. Failure to take precautions to prevent parts from falling as the brake cylinder is removed from the winch may result in personal injury or property damage.

5. Remove the brake cylinder assembly (200) after loosening and removing the twelve capscrews (61) and lockwashers (62) securing it to the ring gear (60). The brake cylinder pilots on the inner diameter of the ring gear and must be pulled straight out to prevent binding.

### **⚠ WARNING ⚠**

The winch planet carrier assemblies and brake cylinder assembly weigh up to 100 lbs (46 kg) each. Ensure the hoist and rigging are rated for this weight. Using a hoist or rigging with insufficient rating may result in personal injury or death.

6. Remove the primary sun gear (58), thrust washer (57), and the primary planet carrier assembly (300).
7. Remove the secondary sun gear (59), thrust washer (56), and the secondary planet carrier assembly (400) from the ring gear (60).
8. Remove the output sun gear (55), thrust washer (54), and output planet carrier assembly (500).
9. Remove the retaining ring (50) from the drum shaft in the primary housing.
10. Secure the ring gear (60) with eye-bolts, an overhead hoist, and rigging in preparation for removing the ring gear (60) and motor-end bearing support (45). Slowly remove the six capscrews (20), nuts (22), and lockwashers (21) that secure the motor-end bearing support to the base-angles and lift the ring gear and motor-end bearing support off of the drum shaft.
11. Remove the thrust washer (44) from the drum shaft.

### **⚠ WARNING ⚠**

The HP50B or HP75A winch drum weighs up to 260 lbs (118 kg). Ensure all lifting equipment including the overhead hoist and rigging have adequate capacity. Use of lifting equipment that does not have adequate lifting capacity or is not properly maintained may result in personal injury or death.

12. Secure the winch drum with lifting straps or a lifting fixture and use an overhead hoist to remove the drum from the drum shaft.

### **⚠ WARNING ⚠**

The winch drum shaft weighs up to 110 lbs (50 kg). Ensure the hoist and rigging are rated for this weight. Using a hoist or rigging with insufficient rating may result in personal injury or death.

13. Remove the drum shaft (49) from the support end bearing leg (5) and remove the sliding clutch (53).
14. Set the base angles (39 and 40) onto the ground and remove the support end bearing leg (5), band brake (2), and air cylinders (3 and 4) if necessary.

For disassembly and reassembly procedures for the brake cylinder, the three planet carrier subassemblies, the overrunning clutch, and the hydraulic motor subassembly, see the subassembly service section in this manual.

## HP50B and HP75A ASSEMBLY

**NOTE:** *The upper level assembly steps for the HP50B and HP75A are the same except for the torque specification on the brake cylinder assembly to ring gear bolts.*

The brake cylinder assembly, the three planet carrier sub-assemblies, the overrunning clutch assembly, and the hydraulic motor subassembly should be assembled following the procedures in this manual before starting this procedure.

All fasteners should be torqued to values in torque table unless a specific torque value is given in the procedure.

### ⚠ WARNING ⚠

The HP50B weighs approximately 1000 lbs (454 kg) and the HP75A weighs approximately 1350 lbs (612 kg). Ensure the hoist and rigging are rated for this weight. Using a hoist or rigging with insufficient rating may result in personal injury or death.

1. Set the base angles (39 and 40) on a work table or on the floor and install the support end bearing leg (5) using capscrews (20), lockwashers (21), and nuts (22). Ensure the bearing leg is in the proper orientation. Torque fasteners to torque table value. Install grease fitting (17) into bearing leg.
2. Bolt the two shifter fork bracket halves (10) to the bearing leg using bolts (34), nuts (18), and lockwashers (19). If the winch uses an air cylinder (4) for freespool shifting, the brackets for mounting the air cylinder are installed using the same bolts (34) on the opposite side of the bearing leg.
3. Install the clutch shifter fork (9) onto the brackets (10) with the clevis pin (11). Install cotter pin (31) and bend ends back to secure clutch shifter fork.
4. Place the sliding clutch (53) on a work bench. Secure the two clutch rider halves (8 and 32) into the sliding clutch groove using capscrews (32), lockwashers (19), and nuts (18). Install grease fitting (17) into clutch rider.

### ⚠ WARNING ⚠

The winch base angles and bearing leg weighs about 300 lbs (136 kg). Ensure the hoist and rigging are rated for this weight. Using a hoist or rigging with insufficient rating may result in personal injury or death.

5. Use an overhead hoist and stand the base angles vertically with the clutch end on the ground. Place a wood spacer block under the bearing leg to keep the base angles level.
6. Apply a light coat of grease to the bearing leg (5) bushing and the splines on the sliding clutch (53). Set

the sliding clutch (53) into the clutch fork slots (9) on the bearing leg in preparation for installing the drum shaft.

7. Install the retaining ring (51) into the groove in the drum shaft (49). Apply a light coat of grease to the splines of the drum shaft and the machined surface of the drum shaft that will slide through the bearing leg (5) bushing.

### ⚠ WARNING ⚠

The winch drum shaft weighs up to 110 lbs (50 kg). Ensure the hoist and rigging are rated for this weight. Using a hoist or rigging with insufficient rating may result in personal injury or death.

8. Put a ½'-13 eye-bolt into the gearbox end of the drum shaft. Use an overhead hoist to lower the drum shaft (49) through the sliding clutch (53) and into the bearing leg bushing (5).
9. Slide the spacer (52) down the drum shaft. It will rest on the retaining ring (51).
10. Install the two dowel pins (7) into the winch drum. Install clutch plate (6) onto dowel pins and install capscrew (24) and lockwashers (29). Torque capscrews to value in torque chart.

### ⚠ WARNING ⚠

The winch drum weighs about 315 lbs (143 kg). Ensure the hoist and rigging are rated for this weight. Using a hoist or rigging with insufficient rating may result in personal injury or death.

11. Apply a light coat of grease to the bushings on each end of the winch drum. Secure the winch drum on the gearbox end with lifting straps or a lifting fixture and use an overhead hoist lower it onto the drum shaft.
12. Place thrust washer (44) into on top of the bushing in the winch drum. Install the cable clamp (35) into the drum using lockwashers (21) and jam nuts (27).
13. Place the motor end support (45) on a clean work bench. Apply Loctite Aviation Gasket Sealant or equivalent non-hardening sealant to the outer surface of the lip seal (47) and install the lip seal in the motor support. Install the bearing (48) in the opposite side of the motor end support.
14. Install the o-ring (46) onto motor end support (45) pilot and apply a light coat of grease. Set ring gear (60) on work bench with the deeper end to gear teeth facing up (shown page 24).

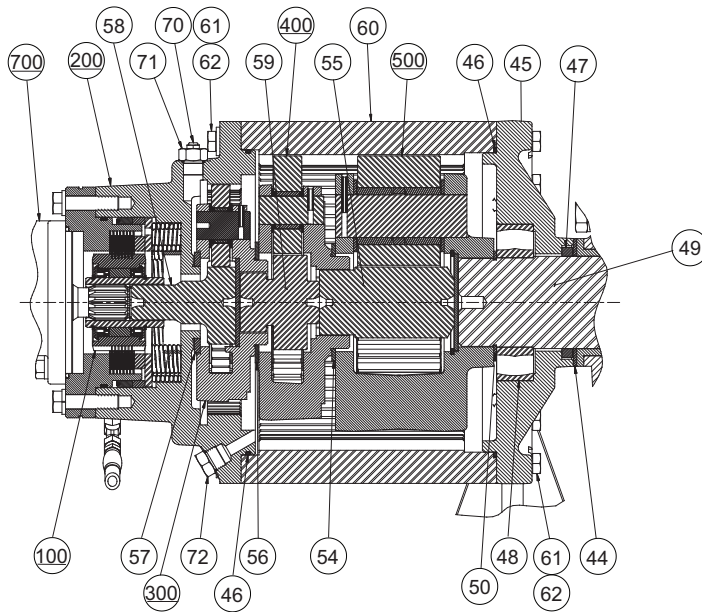

**NOTE:** The HP75A has different brake assembly parts (2 spacers, 10 steel discs) and primary planet carrier assembly. Refer to the brake cylinder, planet carrier, and brake clutch service instructions in this manual for assembly and disassembly of these components.

15. Lower motor end support (45) onto ring gear (60). Apply Loctite 242 to capscrews (60) and install with lockwashers (62) into motor support holes. Torque the capscrews (60) alternating across the ring gear to 117 ft-lbs (159 N-m).
16. Ensure the thrust washer (44) is in place on the winch drum. Apply a light coat of grease to the bearing (48) and seal (47) inner races and use an overhead hoist to lower the ring gear with motor end support onto the winch drum shaft.
17. Install retaining ring (50) onto groove in drum shaft (49). Secure motor end bearing leg (45) onto base angles using capscrews (20), lockwashers (21), and nuts (22).

### ⚠ WARNING ⚠

The winch planet carrier assemblies and brake cylinder assembly weigh up to 100 lbs (46 kg) each. Ensure the hoist and rigging are rated for this weight. Using a hoist or rigging with insufficient rating may result in personal injury or death.

18. Use overhead hoist to lower output planet carrier assembly (500) into ring gear (60). Ensure splines on the output planet carrier assembly fully engage with drum shaft splines.
19. Install sun gear (55) into output planet carrier (500).
20. Apply a coat of grease to thrust washer (54) and slide onto pilot of secondary planet carrier assembly (400). Ensure grease will hold the thrust washer in place and lower secondary planet carrier assembly (400) into the ring gear (60).
21. Install sun gear (59) into secondary planet carrier (400).
22. Apply a coat of grease to thrust washer (56) and slide onto pilot of primary planet carrier assembly (300).

23. Install sun gear (58) into primary planet carrier assembly (300).
24. Install o-ring (46) into groove on the brake cylinder assembly and apply a light coat of grease. Install thrust washer (57) onto brake cylinder pilot and apply grease to hold in place.
25. Use an overhead hoist and lower the brake cylinder assembly (200) onto the ring gear (60). Ensure the brake cylinder is properly aligned with the ring gear.
26. Apply Loctite 242 to capscrews (61) and install with lockwashers (62) into brake cylinder bolt holes. Torque the capscrews (60) alternating across the ring gear to the value for your winch listed below:

HP50B	117 ft-lbs (159 N-m)
HP75A	48 ft-lbs (65 N-m)

**NOTE:** Ensure the brake clutch assembly is installed in the proper orientation and that the inner race snapring is seated on the primary sun gear. On standard rotation winches, the inner race for both the HP50B and HP75A winches should free turn in the clockwise direction viewed from the hydraulic motor side (see Brake Clutch Service section in this manual).

27. Install the brake clutch assembly (100) into the brake cylinder engaging the brake clutch assembly splines with the primary sun gear (58) splines. Ensure the inner race snap ring seats on the sun gear. Ensure proper orientation after installation by turning the sprag assembly in the clockwise direction before installing the motor. The drum should turn in the reel-in direction.
28. Install the o-ring on the hydraulic motor pilot and install the hydraulic motor subassembly on the winch.

# PLANET CARRIER SERVICE

## PRIMARY and SECONDARY PLANET CARRIER

### DISASSEMBLY

**NOTE:** The HP50B primary carrier assembly has the thrust spacer (37) below which is not used in the other HP50B/HP75A primary or secondary planet carriers.

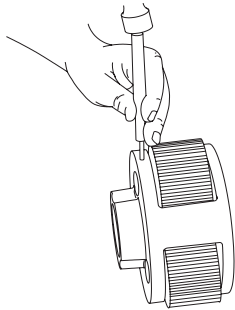
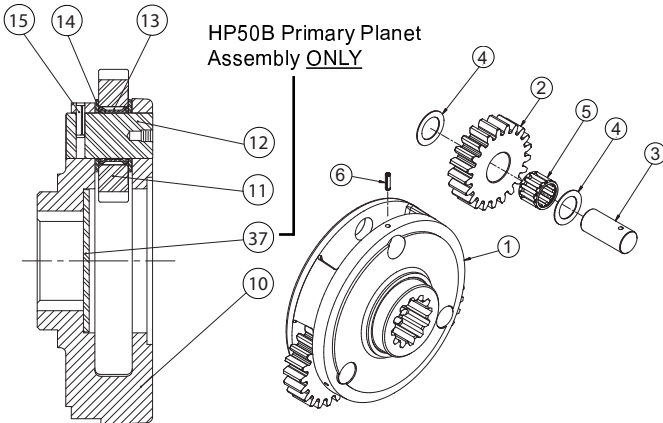

1. Remove the planet gears by first driving the roll pins (item 31) into the center of the planet gear shafts (item 28).

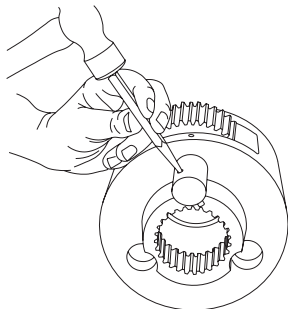

2. Use a punch to drive the roll pins from the planet gear shafts. **DO NOT** reuse the roll pins.

3. Remove the planet shafts, bearings, thrust washers and gears. Thoroughly clean all parts and inspect for damage and wear. The bearing rollers should not exhibit any irregularities. If the rollers show any sign of spalling, corrosion, discoloration, material displacement or abnormal wear, the bearing should be replaced. Likewise, the cage should be inspected for unusual wear or deformation, particularly the cage bars. If there is any damage that will impair the cage's ability to separate, retain and guide the rollers properly, the bearing should be replaced. The thrust washer contact areas should be free from any surface irregularities that may cause abrasions or friction. The gears and shafts should be inspected for abnormal wear or pitting. Replace if necessary.

### ASSEMBLY

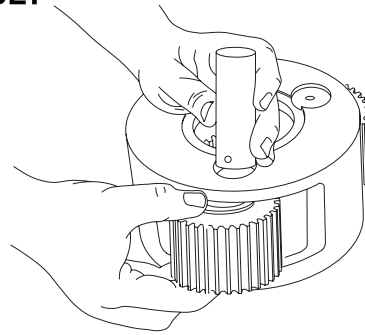

1. Install a bearing into a planet gear and place a thrust washer on each side of the gear. Position this assembly into an opening in the carrier. Slide a planet gear shaft through the carrier, thrust washer, bearing and remaining thrust washer.

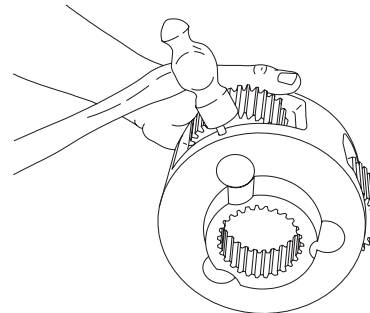

2. Carefully align the pin hole in the carrier with the hole in the shaft and drive a new roll pin into place. **ALWAYS** use **NEW** roll pins. When properly positioned, 50% of the roll pin will engage the planet gear shaft and 50% will remain in the carrier.

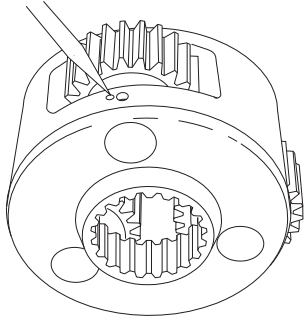

- Note that the roll pin is slightly recessed into the carrier when properly installed. With a center punch, stake the carrier next to the pin hole as shown. This will distort the hole and prevent the pin from backing out in operation. Repeat these steps for each of the three planet gears.

## OUTPUT PLANET CARRIER

### DISASSEMBLY

**NOTE:** The HP50B has three output planet gears and the HP75A has four.

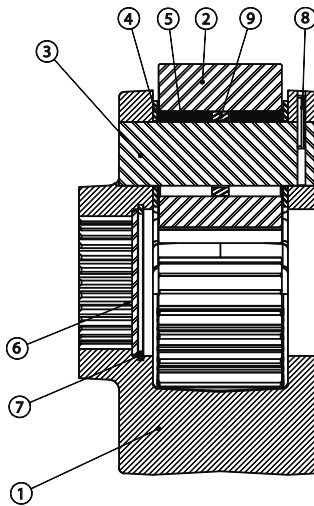

ITEM NO.	DESCRIPTION	QTY
1	PLANET CARRIER	1
2	PLANET GEAR	3
3	OUTPUT PLANET SHAFT	3
4	THRUST WASHER	6
5	ROLLER	132
6	OUTPUT THRUST PLATE	1
7	RETAINING RING	1
8	SPIROL PIN	3
9	BEARING SPACER	3

- Follow steps 1 and 2 of the Primary Planet Carrier disassembly procedure to remove the roll pins from the planet gear shafts.
- Remove the planet shafts, bearings, spacers, thrust washers and gears. Thoroughly clean all parts and inspect for damage and wear. The bearing rollers should not exhibit any irregularities. If the rollers show any sign of spalling, corrosion, discoloration, material displacement or abnormal wear, they should be replaced. The thrust washer contact areas should be free from

any surface irregularities that may cause abrasions or friction. The gears and shafts should be inspected for abnormal wear or pitting. Replace if necessary

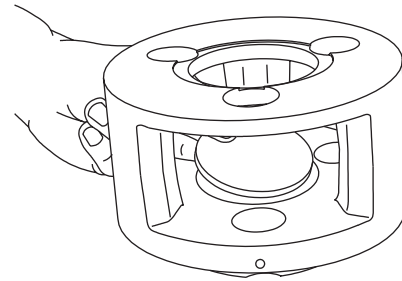

### ASSEMBLY

- Place the output carrier on a clean work surface with the drive pins down. Install the output thrust plate (item 6) into the center of the carrier. Install retaining ring (item 7).
- Apply a liberal coat of oil soluble grease to a thrust washer and center it on one side of a planet gear. Place the planet gear on a clean work surface with the thrust washer down. Apply a liberal coat of oil soluble grease to the bore of the gear. Stack a row of loose roller bearings into the planet gear, using the grease to hold them in position. There are 22 rollers in each row. Install a bearing spacer. Stack a second row of loose roller bearings on top of the bearing spacer. Place a second thrust washer on the planet gear. Carefully slide the planet gear, bearings and thrust washers into the carrier. Install a planet gear shaft into the carrier and through the planet gear bearings.
- Follow steps 2 and 3 of the Primary Planet Carrier assembly procedure to install and stake a **NEW** roll pin in the carrier.

Repeat this procedure for each of the planet gears.

# BRAKE CLUTCH SERVICE

## DISASSEMBLY

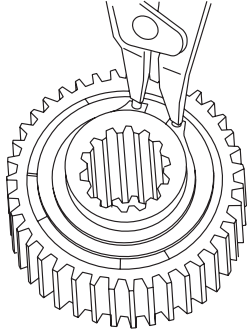

1. Remove the snap ring and sprag bushing retainer from one end only.

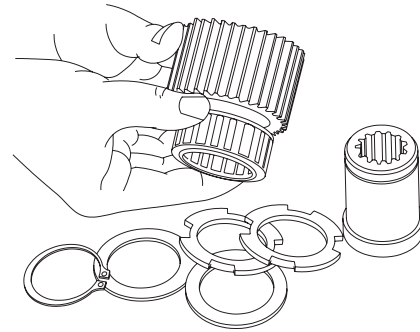

2. Pull the inner race out. Examine the race for scoring, wear or indentations caused by the sprag cams.

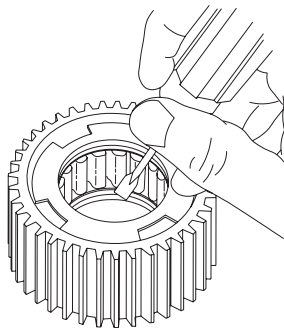
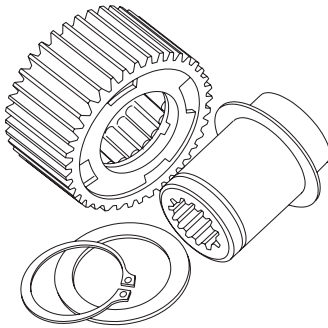

3. Use a screwdriver and mallet to remove the sprag bushing from one end of the outer race. There are four special cut-outs in the bushing for this purpose. Be careful not to damage the bushing inside surface. If a bushing's inside surface is damaged or shows wear, replace it.

4. Next, slide the sprag clutch out, inspect the sprag clutch closely for abnormal wear, cracks, pitting or corrosion. Check small clips for breakage or bright spots; the signs of excessive wear. Unless the outer race or remaining sprag bushing is damaged or shows excessive wear, there is no need for further disassembly. If disassembly is necessary, remove the bushing according to the procedure covered in Step No. three (3). All brake clutch assembly parts should be thoroughly cleaned and inspected before assembly.

### **⚠ WARNING ⚠**

The polished surfaces of the races and sprag cams must be perfectly smooth to insure positive engagement of the clutch. Any defect in inner race, outer race, or sprag clutch requires replacement of the complete brake clutch assembly. The slightest defect may reduce brake clutch effectiveness, which may lead to loss of load control and result in property damage, personal injury or death.



## ASSEMBLY

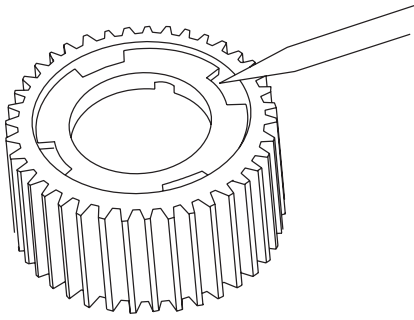

1. Press a sprag bushing into the outer race, using a mechanical or hydraulic press. A flat plate of approximately the same diameter as the bushing flange outside diameter should be placed between the press and bushing during assembly to protect the bushing. Be certain the bushing flange is against the shoulder in the outer race.

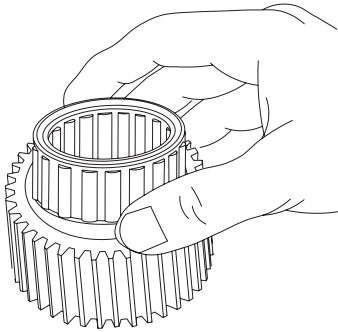

2. Turn the assembly over and install the sprag clutch in the bore of the outer race.
3. Press the remaining bushing into the race. Again, make sure the bushing is against the shoulder.

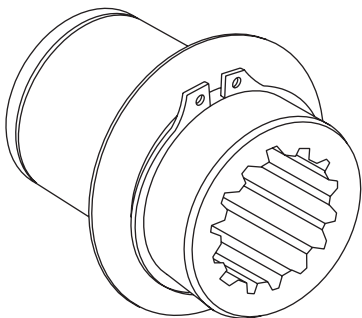

4. Next, install a sprag bushing retainer, then a snap ring on the inner race. Be sure the snap ring is seated in the snap ring groove.

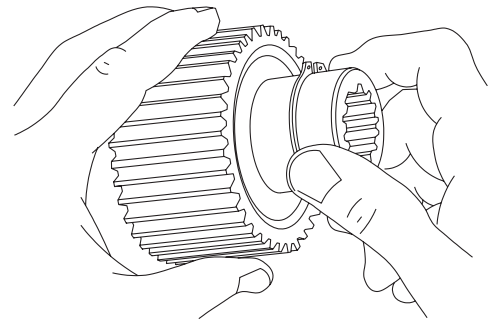

5. Slide the inner race through the bushings and sprag clutch (the race will have to be rotated in the free-wheeling direction to start it through the sprag clutch). If the inner race will not go through the bushings, the bushings have probably been damaged and should be replaced.

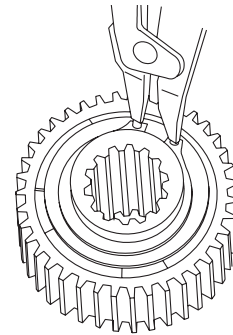

6. Turn the assembly over with the snap ring down. Install the second retainer and snap ring. Make certain the snap ring is seated in the groove properly.

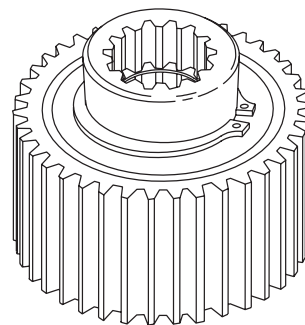

7. This is a completed brake clutch assembly.

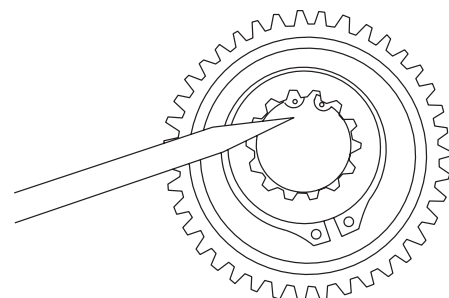

# ⚠ WARNING ⚠

Be certain the snap ring is seated in the groove in the splined bore of the inner race. This snap ring will keep the brake clutch assembly correctly positioned in the center of the friction brake pack. Binding of the brake or brake failure may occur if this snap ring is omitted.

## HP50B

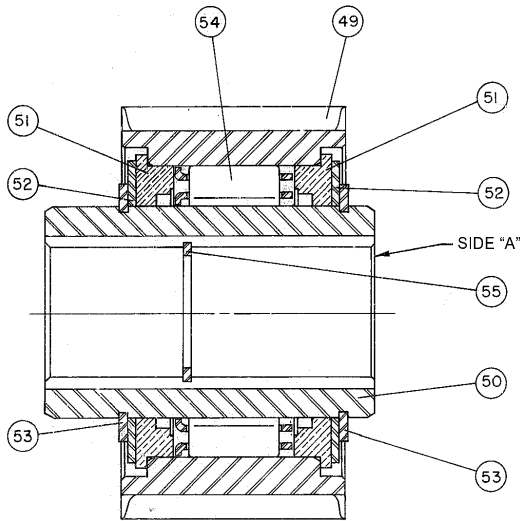

**NOTE:** For a standard rotation winch, the inner race (50) should free turn in the clockwise direction viewed from side "A" which is the hydraulic motor side.

## HP75A

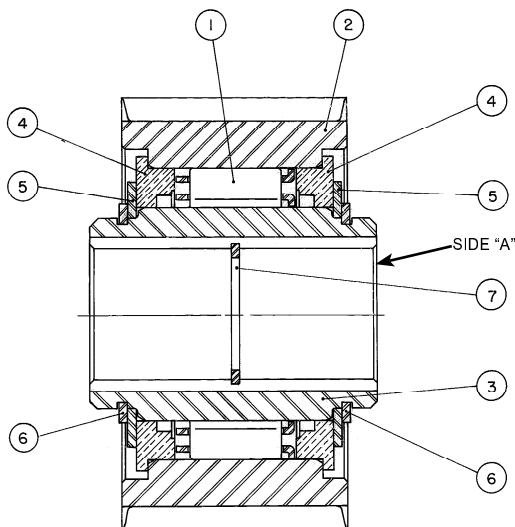

**NOTE:** Though the HP75A brake clutch assembly is symmetrical in appearance, it must be installed in the winch so that the inner race turns freely in the clockwise direction when viewed from the motor shaft side (side "A" on drawing above).

# BRAKE CYLINDER SERVICE

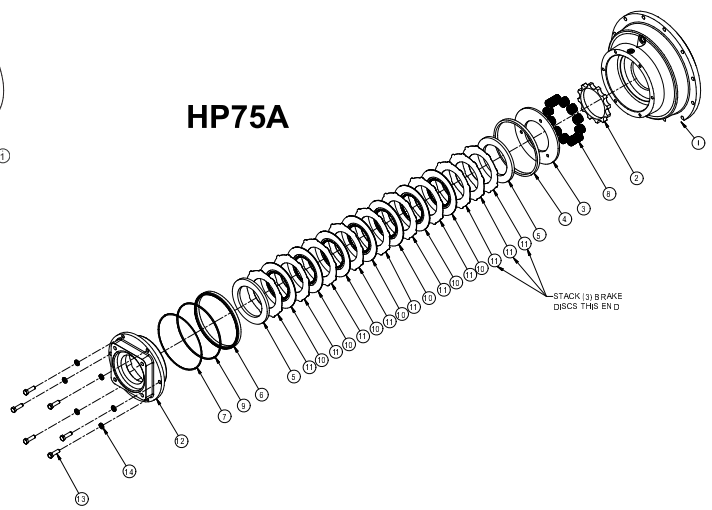
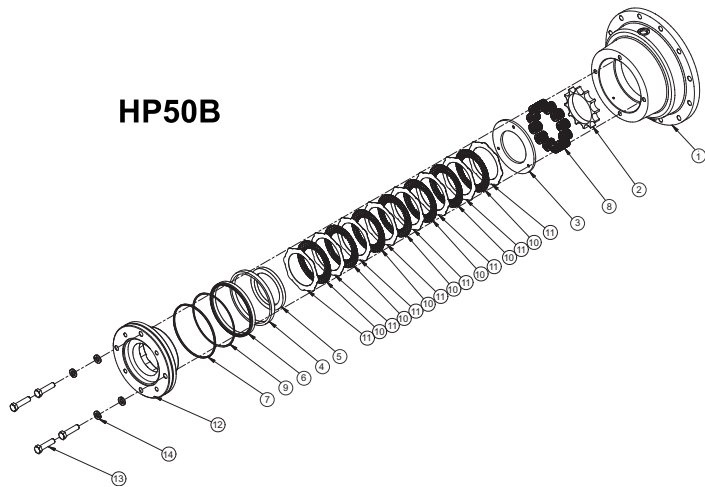

## DISASSEMBLY

### ⚠ CAUTION ⚠

The motor adapter is under spring tension from the brake springs. Loosen each of the capscrews one turn at a time until spring tension is released.

1. Set the brake assembly on a work bench with the motor adapter up. Remove the capscrews (item 13) and lockwashers (item 14). Use a crisscross pattern and loosen each capscrew one turn at a time until spring tension is released.
2. Remove the motor adapter (item 12). Lift out all the brake discs (item 11), friction discs (item 10) and the spacer (item 5). **NOTE:** *There are two spacers (item 5) in the HP75A.*
3. Remove and discard the O-Ring and backup ring (items 9 & 7) from the motor adapter. Remove and discard the brake piston seal (item 6) from the brake cylinder. Remove the steel piston backup ring (item 4).
4. Remove the pressure plate (item 3) and the springs and spring spacer (items 8 & 2) from the brake cylinder.

## Clean and Inspect

1. Thoroughly clean and inspect all parts at this time. Check sealing surfaces on both the motor adapter and brake cylinder. Be sure the brake release port is open and free of contamination.
2. Place friction brake disc on flat surface and check for distortion with a straight edge. Friction material should appear even across entire surface with groove pattern visible. Replace friction disc if splines are worn to a point, disc is distorted, friction material is burned or worn unevenly, or groove depth is less than 0.003 in. (0.08 mm).
3. Place steel disc on flat surface and check for distortion with a straight edge. Check surface for signs of material transfer or excessive heat. Replace steel disc if distorted, heat discolored, or mechanically damaged.
4. Check brake spring free length. Check springs for any signs of cracking or failure. If a brake spring must be replaced for any reason, then ALL brake springs must be replaced.

### Minimum Free Length

HP50B	1-3/16 inch (30.2 mm)
HP75A	1.0 inch (25.4 mm)

### ⚠ WARNING ⚠

Brake springs must be replaced as a set. Failure to replace brake springs as a set may result in uneven brake application pressure and repeated brake spring failure, resulting in personal injury or death.

## ASSEMBLY

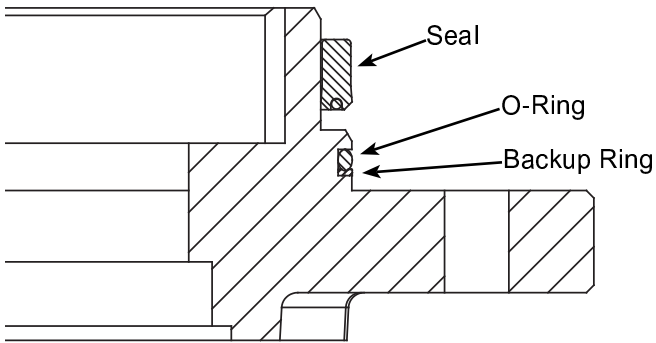

1. Place the motor adapter (item 12) on a clean work surface with the motor mounting surface down. Apply a light coat of oil to a new backup ring (item 7) and O-Ring (item 9) and install them into the groove on the motor adapter. Backup rings are always placed on the low pressure side of the O-Ring. In this case, the backup ring is toward the motor mounting surface. Lightly oil the brake cylinder seal (item 6) and install it onto the motor adapter with the seal lip down.
2. For **HP75A ONLY**, install spacer (item 5) in brake cylinder.
3. Lubricate the friction discs with the same oil used in the hoist. Install a steel brake disc (item 11) into the motor adapter, followed by a friction disc (item 10). Continue to alternately install steel and friction discs until there are 8 steel and 7 friction discs. A steel disc will be on top. For **HP75A ONLY**, two additional steel discs are placed on the existing steel discs (10 total).
4. Install the brake plate spacer (item 5) on top of the last steel disc.
5. Place the brake housing (item 1) on a clean work surface with the motor end facing up. Install the spring spacer (item 2), then the 12 springs (item 8).
6. Install the pressure plate (item 3) into the brake housing. Be careful that none of the springs fall over. Install the steel backup ring (item 4).

**NOTE:** The close fitting backup ring may be depressed slightly to one side to lodge it in the brake cylinder bore and temporarily hold the pressure plate and springs in place while the brake cylinder is inverted and lowered over the motor adapter. As an alternate, the motor adapter and brake plates can be turned over and installed into the brake cylinder, holding the brake plates and spacer in place through the center opening. Be careful to not pinch your fingers between the spacer plate and the pressure plate.

7. Apply petroleum jelly or oil soluble grease to the sealing surface of the brake housing and the piston seal. Turn the brake housing over and lower it onto the motor adapter, being careful not to damage the piston seal or O-Ring on the adapter. The alternate assembly method above can also be used.
8. Turn the entire assembly over and install the capscrews and lockwashers. After the capscrews make contact with the motor adapter, evenly tighten them one turn at a time until the motor adapter is drawn tight against the brake cylinder, then torque to the recommended value.

## BRAKE CYLINDER PRESSURE TEST

1. Install a -4 ORB fitting into the brake release port on the motor adapter. Connect a hand pump with an accurate 0-2,000 psi (0-13,800 kPa) gauge and shut-off valve to this fitting. Apply 1,000 psi (6,900 kPa) to the brake and close the shut-off valve. Let the unit stand for five minutes. If there is any loss of pressure, the brake cylinder should be disassembled for inspection of the sealing surfaces, seal and O-Ring. When the source of the pressure leak has been determined and corrected, re-assemble the brake cylinder and repeat the test.
2. WHILE PRESSURE IS APPLIED AND THE BRAKE IS RELEASED, install the over-running clutch assembly into the brake pack. Turn the clutch back and forth to align the splines on all the friction discs. Release the pressure on the brake cylinder and remove the clutch assembly. The brake cylinder is now complete and ready to be installed in the hoist.

### ⚠ WARNING ⚠

Always use the molded spring spacer to properly position the springs in the brake cylinder. Failure to install the spring spacer may allow the springs to contact each other and become damaged. This could result in loss of load control, property damage, injury or death.

# HP50B AND HP75A ROTATION CHANGE

This winch as shipped from the factory is configured for installation with the motor on the passenger side of the truck bed and the cable reeling-in over the drum as shown below.

The three basic changes that are required to change the rotation and are detailed in this procedure are:

1. The brake valve and shift block must be moved to the opposite side of the hydraulic motor.
2. The brake clutch assembly must be set-up for the new direction of rotation. For the HP50B this requires disassembly of the brake clutch. For the HP75A, the brake clutch is not disassembled, but it is rotated 180 degrees in the winch.
3. The band brake assembly is reversed on the winch.

The drawing below is the standard configuration of the winch from the factory.

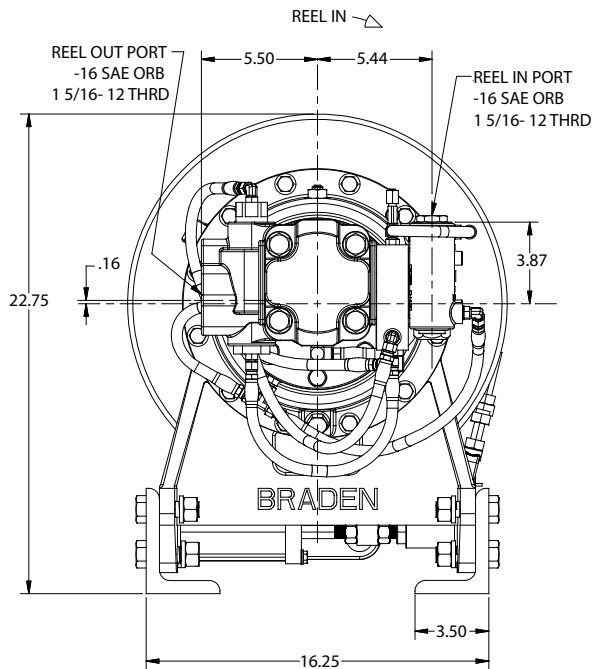

If the winch must be mounted behind the truck cab with the motor on the driver's side of the truck and the winch reeling-in over the drum, the following changes must be made for proper operation:

1. The brake valve and shift block must be moved to the opposite side of the winch motor.

**a) For the Commercial two-speed motor ONLY:** This procedure should be done by a Parker/Commercial dealer so that the hydraulic motor retains its warranty. The motor must be taken apart and the center section (dotted lines) rotated 180 degrees to get the brake valve on the opposite side. This must be done because this two speed motor has a -16 ORB port on the reel-out side of the hydraulic motor.

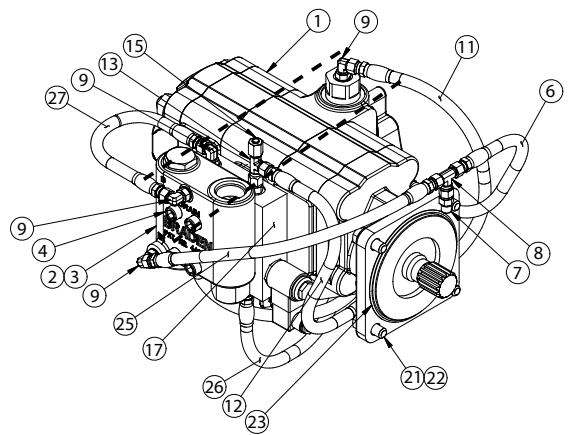

**b) For the Rineer two-speed motor and Commercial single speed motor,** the brake valve and shift-block must be moved to the opposite side motor split flange port. The plumbing must be changed so the lowering signal to the brake and brake valve comes from the opposite side as originally plumbed.

2. The brake clutch must be configured for counter clockwise rotation viewed from the hydraulic motor side of the drum.

**a) For the HP50B** the brake clutch must be taken apart and the sprag flipped. After reassembly, the inner race should free turn in the CCW direction viewed from the motor side.

**b) For the HP75A** the brake clutch is symmetrical, so the complete assembly is flipped 180 degrees so that it rotates freely in the CCW direction when viewed from the motor side. Disassembly of the brake clutch is not required on the HP75A.

HP50B SPRAG

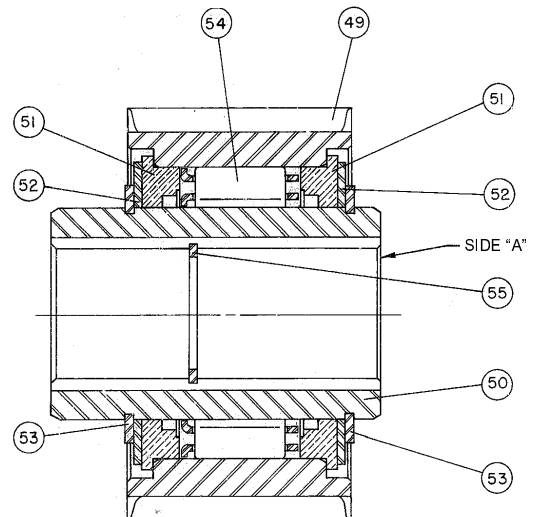

Free rotation is changed to CCW viewed from side "A" (motor side) when motor is mounted on driver's side and rope winds over drum.

3. Band brake must be reversed on the winch.