

---

# BRADEN

---

## PD21A PLANETARY HOIST

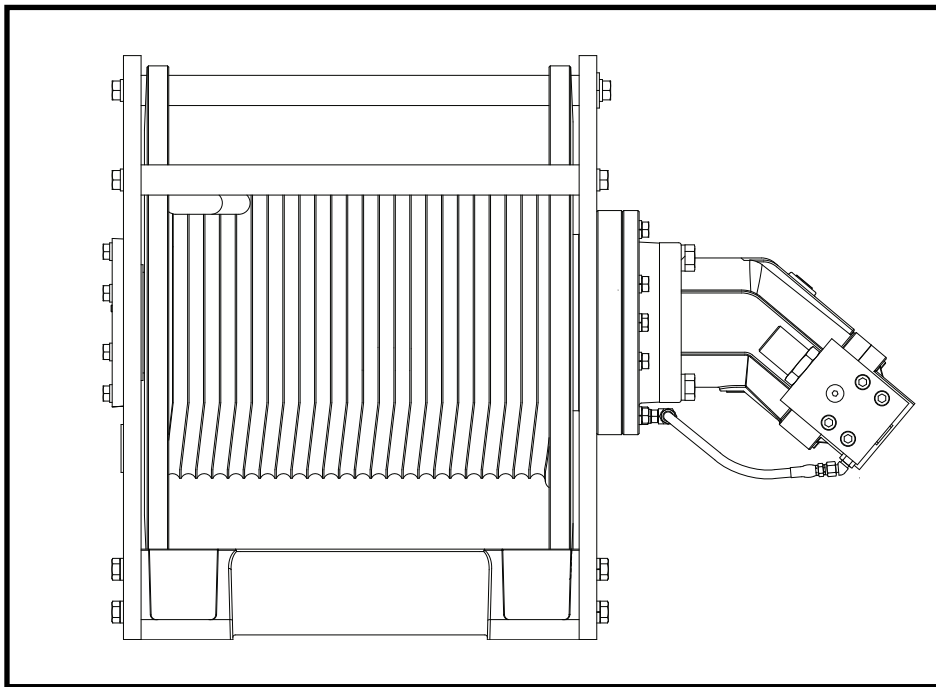

### INSTALLATION, MAINTENANCE AND SERVICE MANUAL

# TABLE OF CONTENTS

FOREWORD .....	2
MODEL & SERIAL NUMBER LOCATION .....	2
EXPLANATION OF MODEL NUMBER .....	2
GLOSSARY OF TERMS .....	3
GENERAL SAFETY RECOMMENDATIONS .....	4
BASIC OPERATION .....	6
EXPLODED VIEW OF MAJOR COMPONENTS .....	8
INSTALLATION .....	9
WIRE ROPE INSTALLATION .....	9
HOIST OPERATION .....	11
HYDRAULIC CIRCUIT .....	12
RECOMMENDED FASTENER TORQUE .....	12
PREVENTIVE MAINTENANCE .....	13
RECOMMENDED GEAR OIL .....	14
OIL SAMPLING AND ANALYSIS .....	15
TROUBLESHOOTING .....	16
DISASSEMBLY PROCEDURE .....	20
PLANETARY CARRIER SERVICE .....	21
OVER-RUNNING CLUTCH SERVICE .....	23
BRAKE CYLINDER SERVICE .....	24
HOIST ASSEMBLY .....	27
MOTOR GROUP ILLUSTRATIONS .....	28
BRAKE VALVE SERVICE .....	29

# FOREWORD

The following service instructions have been prepared to provide assembly, disassembly and maintenance information for the BRADEN Model PD21A series hoist. It is suggested that before doing any work on these units, all assembly and disassembly instructions should be read and understood.

Some pictures in this manual may show details or attachments that are different from your hoist. Also, some components have been removed for illustrative purposes.

Continuing product improvement may cause changes in your hoist, which are not included in this manual. Whenever a question arises regarding your BRADEN hoist or this manual, please contact BRADEN Service Department for the latest available information.

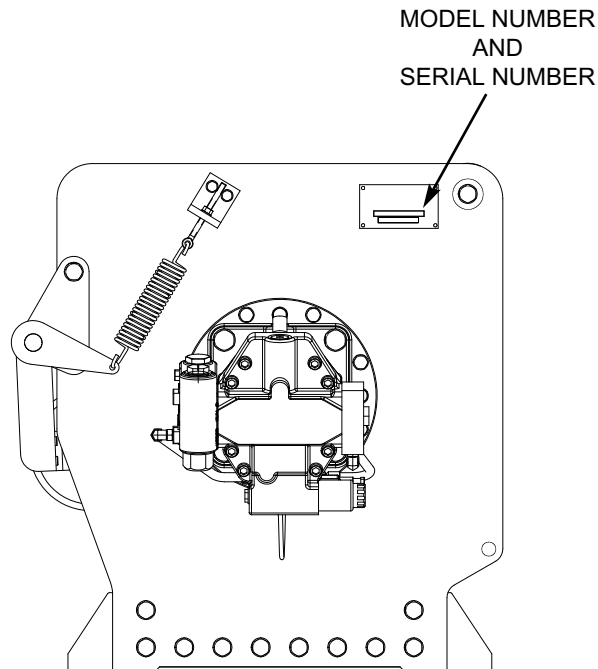

## MODEL NUMBER AND SERIAL NUMBER

When information on a hoist is needed, always refer to the model number and serial number. Both are located on the top of the motor side end plate as indicated above.

## EXPLANATION OF MODEL NUMBER

**PD 21 A - 50 P 065 - 08 G**

<b>PD</b>	POWER DRUM
<b>21</b>	DESIGNATES BASIC MODEL NUMBER
<b>A</b>	DESIGNATES MODEL SERIES
<b>50</b>	DESIGNATES TOTAL GEAR REDUCTION (50:1)
<b>P</b>	PISTON TYPE HYDRAULIC MOTOR
<b>065</b>	DESIGNATES HYDRAULIC MOTOR DISPLACEMENT IN CU IN/REV (065 = 6.5 CU IN/REV.)
<b>08</b>	DRUM MODEL
<b>G</b>	GROOVED DRUM

# GLOSSARY OF TERMS

**Brake Valve** - A hydraulic counterbalance valve is usually bolted to the hoist port of the hydraulic motor. It allows oil to flow freely through the motor in the hoisting direction. When oil pressure tries to rotate the motor in the lowering direction, the brake valve blocks the flow of oil out of the motor until the internal static brake is released. It then controls lowering speed based on the load and flow of oil to the motor. All the heat generated by controlling the speed of the load is dissipated by the hydraulic system, not by the internal static brake.

**Grooved Drum** - A cable drum with grooves on the barrel to ensure the first layer of cable spools properly onto the drum. The grooves can be cast or machined into the drum, or cast or machined into separate pieces that are mechanically fastened to the drum. **NOTE:** Only one size cable can be used on a grooved drum.

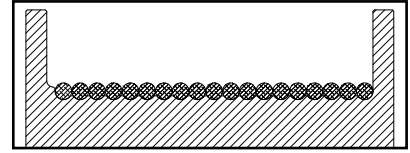

**Sprag or Over-Running Clutch** - A mechanical one-way clutch on the input shaft of the hoist, between the input shaft and the static mechanical brake. The clutch allows the input shaft to turn freely in the direction required to spool cable onto the drum (i.e. lift a load), then immediately locks the hoist gear train to the mechanical brake when the hoist is stopped, holding the load in place.

**Static, Mechanical, or Load-Holding Brake** - A multi-disc, spring applied, hydraulically released brake that works together with the sprag clutch to hold a suspended load. This brake is not designed to stop a load being lowered, but holds the load in place when the hoist is not being operated.

**First Layer Line Pull Rating** - The maximum rated line pull (in pounds or kilograms) on the first layer of cable. The maximum rating for any particular hoist is based on maintaining an acceptable structural design factor and service life. Certain combinations of drum, gear ratio, motor and hydraulic pressure, may reduce this rating.

**First Layer Line Speed Rating** - The maximum rated line speed (in feet or meters per minute) on the first layer of cable. Certain combinations of drum, gear ratio, motor and hydraulic flow may reduce or increase this rating.

**D/d Ratio** - The ratio of cable drum barrel diameter (D) to wire rope diameter (d). Current ANSI standards require a minimum of 17:1.

**EXAMPLES:**

If you know the cable diameter you want to use, multiply it by 17 to get the **MINIMUM** cable drum barrel diameter. (i.e. ½ inch wire rope X 17 = 8.5 inches - this is the **minimum** hoist barrel diameter)

If you know the barrel diameter, divide it by 17 to get the **MAXIMUM** wire rope diameter.

(i.e. 10 inch barrel diameter / 17 = 0.588, or 9/16 inch - this is the **maximum** wire rope diameter)

**Cable Drum Dimensions -**

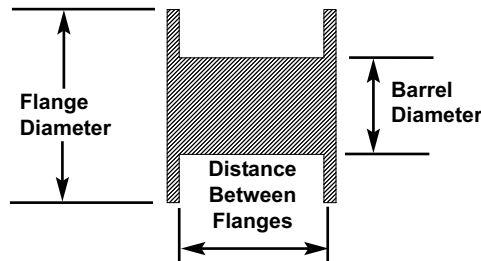

**Fleet Angle** - The angle between the wire rope's position at the extreme end wrap on a drum, and a line drawn perpendicular to the axis of the drum, through the center of the nearest fixed sheave or load attachment point.

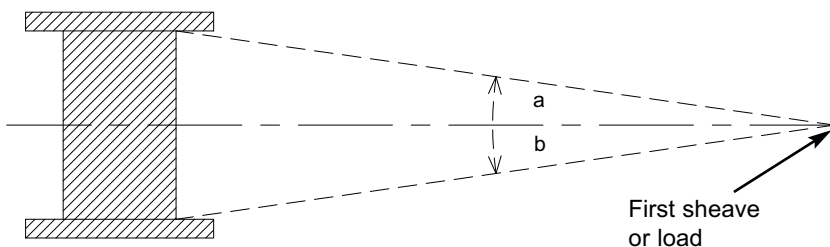

First sheave or load should be centered between the drum flanges, so that angle "a" and angle "b" are equal.

Angles "a" and "b" should be a minimum of ½ degree and a maximum of 1½ degrees.

**Wrap** - A single coil of wire rope wound on a drum.

**Layer** - All wraps of wire rope on the same level between drum flanges.

**Freeboard** - The amount of drum flange that is exposed radially past the last layer of wire rope. Minimum freeboard varies with the regulatory organization. ASME B30.5 requires ½ in. minimum freeboard.

# GENERAL SAFETY RECOMMENDATIONS



Safety for operators and ground personnel is of prime concern. Always take the necessary precautions to ensure safety to others as well as yourself. To ensure safety, the prime mover and hoist must be operated with care and concern for the equipment and a thorough knowledge of the machine's performance capabilities. The following recommendations are offered as a general safety guide. Local rules and regulations will also apply.

1. Be certain equipment (boom, sheave blocks, pendants, etc.) is either lowered to the ground or blocked securely before servicing, adjusting, or repairing hoist.
2. Be sure personnel are clear of work area BEFORE operating hoist.
3. Read all warning and caution tags provided for safe operation and service of the hoist and become familiar with the operation and function of all controls before operating the hoist.
4. Inspect rigging and hoist at the beginning of each work shift. Defects should be corrected immediately. Do not operate a hoist with defects.
5. Keep equipment in good operating condition. Perform scheduled servicing and adjustments listed in the "Preventive Maintenance" section of this manual.
6. An equipment warm-up procedure is recommended for all start-ups and essential at ambient temperatures below +40°F (+4°C). Refer to "Warm-up Procedure" listed in the "Preventive Maintenance" section of this manual.
7. Do not exceed the maximum pressure (PSI, kPa) or flow (GPM, lpm) stated in the hoist specifications found in the specific sales brochure.
8. Operate hoist line speeds to match job conditions.
9. Protective gloves should be used when handling wire rope.
10. Never attempt to handle wire rope when the hook end is not free. Keep all parts of body and clothing clear of cable rollers, cable entry area of fairleads, sheaves and hoist drum.
11. When winding wire rope on the hoist drum, never attempt to maintain tension by allowing wire rope to slip through hands. Always use "Hand-Over-Hand" technique.
12. Never use wire rope with broken strands. Replace wire rope that is damaged. Refer to wire rope supplier manual.
13. Do not weld on any part of the hoist without approval from PACCAR Winch Engineering.
14. Use recommended hydraulic oil and gear lubricant.
15. Keep hydraulic system clean and free from contamination at all times.
16. Use correct anchor for wire rope and pocket in drum.
17. Do not use knots to secure or attach wire rope.
18. The BRADEN designed wire rope anchors are not intended to support the rated load. ALWAYS maintain a minimum of five (5) wraps of wire rope on the drum. It is recommended that the last five (5) wraps of wire rope be painted bright red to serve as a visual reminder.
19. Never attempt to clean, oil or perform any maintenance on a machine with the engine or prime mover running, unless instructed to do so in this manual.
20. Never operate hoist controls unless you are properly positioned at the operators station and you are sure personnel are clear of the work area.
21. Assure that personnel who are responsible for hand signals are clearly visible and that the signals to be used are thoroughly understood by everyone.
22. Ground personnel should stay in view of the operator and clear of the hoist drum. Do not allow ground personnel near wire rope under tension. A safe distance of 1½ times the working length of the wire rope should be maintained.
23. Install guarding to prevent personnel from getting any part of body or clothing caught at a point where the cable is wrapped onto the drum or drawn through guide rollers or potential "pinch points".
24. Install switches or valves that will shut off power to the hoist, in locations where they can be reached by anyone entangled in the wire rope before being drawn into the hoist or any "pinch point".
25. "Deadman" controls, which automatically shut off power to the hoist whenever the operator leaves his station or releases the hoist control lever, should be installed whenever practical.
26. Never allow anyone to position any part of body under a suspended load.
27. Avoid sudden "shock" loads or attempting to "jerk" a load free. This type of operation may cause heavy loads, in excess of rated capacity, which may result in failure of wire rope, hoist or crane structure.
28. Whenever possible, install the hoist in a location that is not immediately adjacent to a "normal" operator's station.
29. All hoist controls shall be located within easy reach of the operator. The controls shall be installed in such a location that the operator is removed from the electrical path to ground if the load, rigging, or wire rope come in contact with or within proximity to an electrically energized conductor.



30. Before operating the hoist, be sure ALL safety procedures for the equipment or vehicle the hoist is mounted on are properly followed and/or in place.

If there is any question regarding the preceding safety recommendations, or the safe operation of your hoist, please contact the Braden Product Support Department at 1-918-251-8511, Monday through Friday from 0800 to 1630 hours, CST, by fax at (918) 259-1575, or via the internet at [www.paccarwinch.com](http://www.paccarwinch.com) for the latest available information.

Safety and informational callouts used in this manual include:

 **WARNING** 

**WARNING** – This emblem is used to warn against hazards and unsafe practice which **COULD** result in severe personal injury or death if proper procedures are not followed.

 **CAUTION** 

**CAUTION** – This emblem is used to warn against potential or unsafe practices which **COULD** result in personal injury and product or property damage if proper procedures are not followed.

# BASIC OPERATION

## DESCRIPTION OF HOIST

The PD21A hoist is made up of the following sub-assemblies:

1. Hydraulic motor and brake valve
2. Brake cylinder and brake clutch assembly
3. Hoist base components
4. Hoist drum and gear train

(Refer to illustration on page 8)

## THEORY OF OPERATION

The primary sun gear is directly coupled to the hydraulic motor by the inner race of the brake clutch assembly. As the motor turns in the hoisting direction (clockwise), the planetary assemblies reduce the input speed of the motor and rotate the ring gear and winch drum. Since the output planet carrier is held from turning by the brake cylinder, the drum rotates in the opposite direction of the motor input shaft. In the hoisting direction, the static brake remains fully applied and the input shaft rotates freely through the sprag clutch. When the motor is stopped, the load tries to rotate the hoist gear train in the opposite direction. The sprag clutch on the input shaft immediately locks up, allowing the fully applied static brake to hold the load from dropping. See Dual Brake System - Operation for a detailed description of the lowering sequence of operation.

### DUAL BRAKE SYSTEM – DESCRIPTION

The dual brake system consists of a dynamic brake system and a static brake system.

The dynamic brake system has two operating components:

1. Brake valve assembly
2. Hydraulic motor

The brake valve is basically a counterbalance valve with improved metering. It contains a check valve to allow free flow of oil to the motor in the hoisting direction and a pilot operated, spring-loaded spool valve that blocks the flow of oil out of the motor when the control valve is placed in neutral. When the control valve is placed in the lowering position, the spool valve remains closed until sufficient pilot pressure is applied to the end of the spool to shift it against spring pressure and open a passage. After the spool valve cracks open, the pilot pressure becomes flow-dependent and modulates the spool valve opening which controls the lowering speed. See figures 2, 3 and 4.

The static brake system has three operating components:

1. Spring Applied, Multiple Friction Disc Static Brake
2. Brake Clutch Assembly
3. Hydraulic Piston and Cylinder

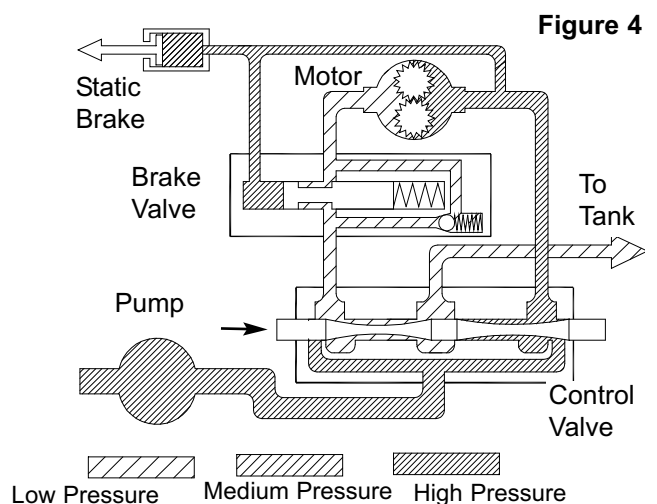
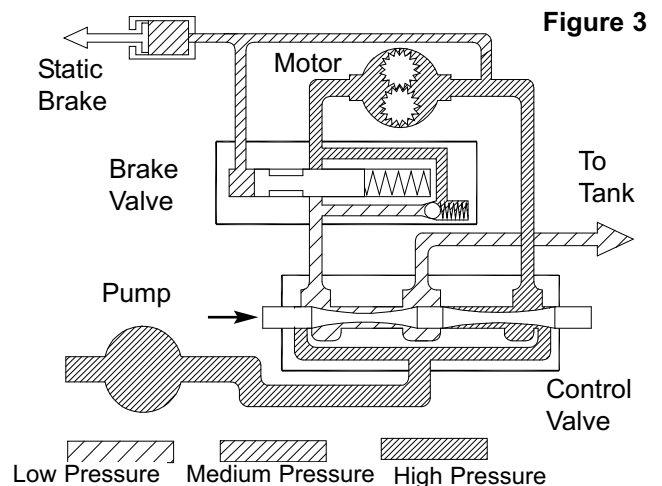
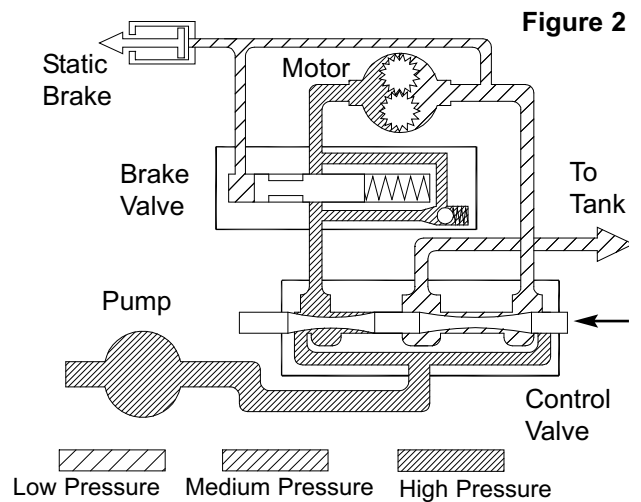

The static brake is released by the brake valve pilot pressure at a pressure lower than that required to open the pilot operated spool valve. This sequence assures that dynamic braking takes place in the brake valve and that little, if any, heat is absorbed by the friction brake.

The static friction brake is a load holding brake only and has nothing to do with dynamic braking or rate of descent of a load.

The brake clutch is splined to the primary sun gear shaft between the motor and the primary sun gear. It will allow this shaft to turn freely in the direction to raise a load and lock up to force the brake discs to turn with the shaft in the direction to lower a load. Figures 5 and 6.

The hydraulic cylinder, when pressurized, will release the spring pressure on the brake discs, allowing the brake discs to turn freely.

**DUAL BRAKE SYSTEM – OPERATION**

When hoisting a load, the brake clutch which connects the motor shaft to the primary sun gear, allows free rotation. The sprag cams lay over and permit the inner race to turn free of the outer race. Figure 5. The static friction brake remains fully engaged. The hoist, in raising a load, is not affected by any braking action. Figure 2.

When the lifting operation is stopped, the load attempts to turn the primary sun gear in the opposite direction. This reversed input causes the sprag cams to instantly roll upward and firmly lock the shaft to the fully engaged friction brake. Figure 6.

When the hoist is powered in reverse, to lower the load, the motor cannot rotate until sufficient pilot pressure is present to open the brake valve. Figures 3 & 4. The friction brake within the hoist will completely release at a pressure lower than that required to open the brake valve. The extent to which the brake valve opens will determine the amount of oil that can flow through it and the speed at which the load will be lowered. Increasing the flow of oil to the hoist motor will cause the pressure to rise and the opening in the brake valve to enlarge, speeding up the descent of the load. Decreasing this flow causes the pressure to lower and the opening in the brake valve to decrease thus slowing the descent of the load.

When the control valve is shifted to neutral, the pressure will drop and the brake valve will close, stopping the load. The friction brake will engage and hold the load after the brake valve has closed.

When lowering a load very slowly for precise positioning, very little oil flow actually occurs through the hoist motor. The pressure will build up to a point where the static brake will release sufficiently to allow the load to

rotate the motor through its own internal leakage. This feature results in a very slow speed and extremely accurate positioning.

The friction brake receives very little wear in the lowering operation. All of the heat generated by the lowering and stopping of a load is absorbed by the hydraulic oil where it can be readily dissipated.

**Figure 5** Static Friction Brake Applied

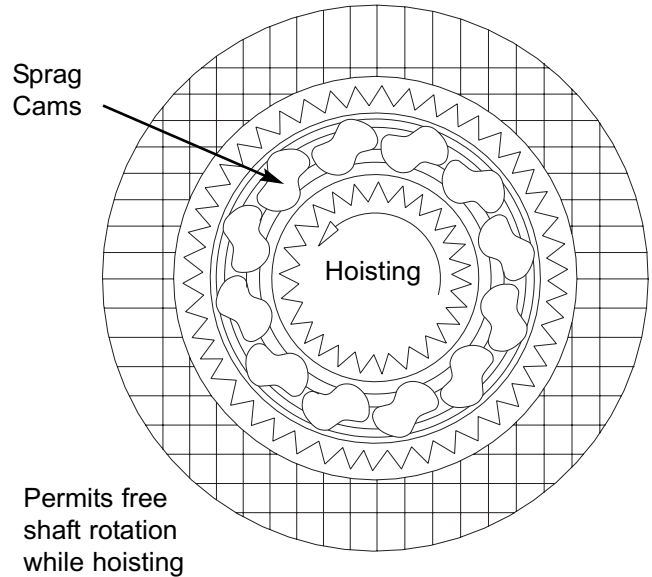

**Figure 6** Static Friction Brake Applied

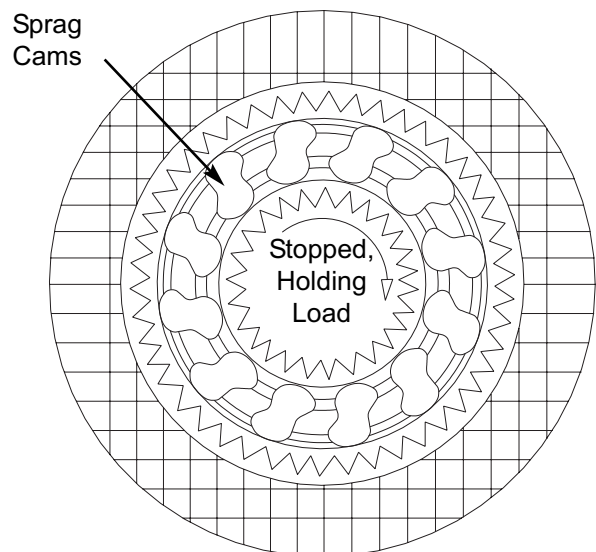

Load attempts to rotate shaft in opposite direction. Brake clutch locks sun gear shaft to friction brake.



# PD21A COMPONENTS

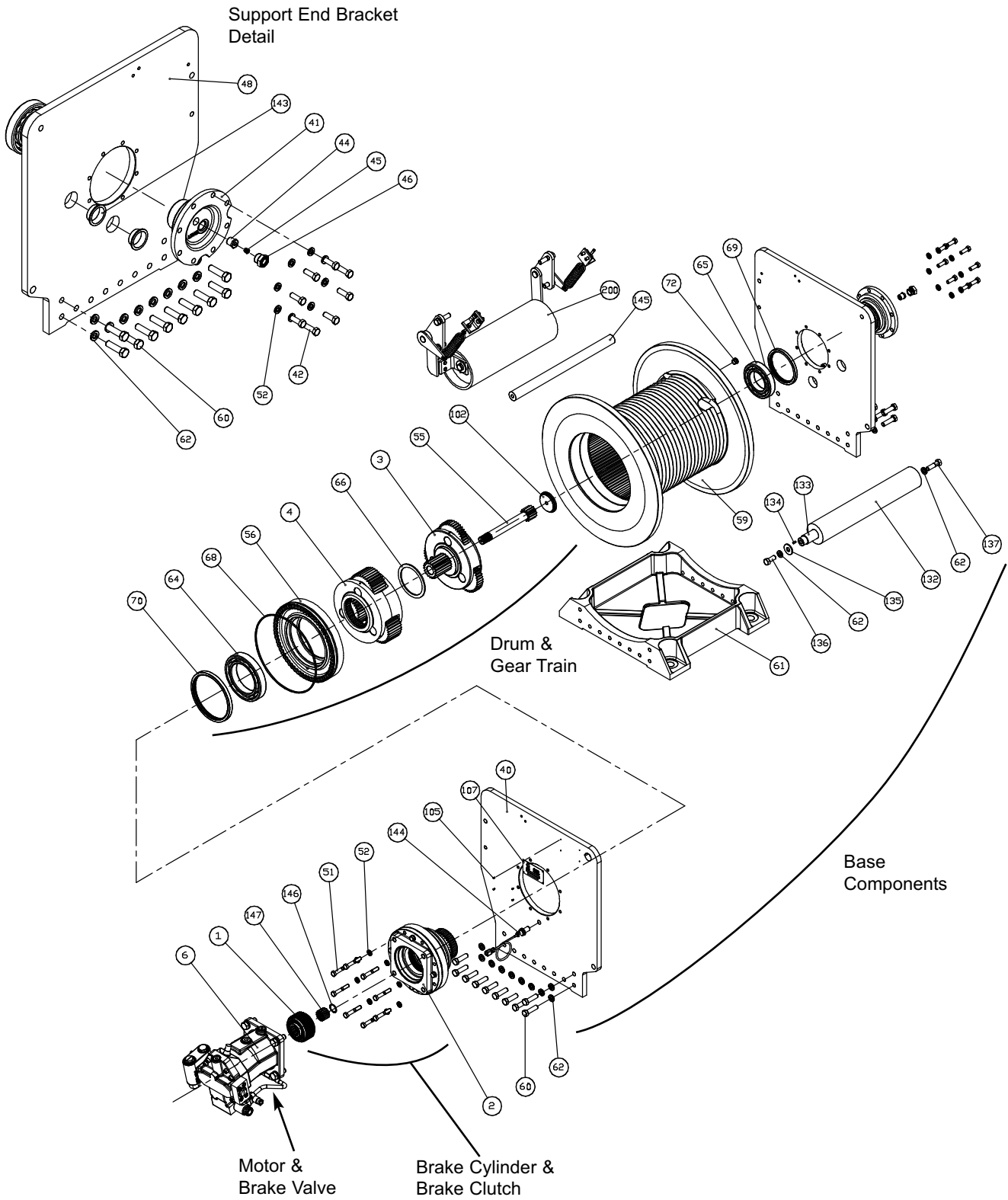

# INSTALLATION

## GENERAL REQUIREMENTS

1. The hoist must be mounted with the centerline of the drum in a horizontal position. The mounting plane can be rotated to any position around this centerline, providing the vent plug is positioned above the oil level.
2. When mounting the hoist, we recommend grade eight bolts and nuts. All mounting holes in the hoist base must be used.
3. The vent plug must always be located above the horizontal centerline of the hoist drum. If the hoist is mounted on a pivoting surface, be sure the vent remains above the centerline at all times. If necessary, reposition the bearing support.
4. It is important that the hoist be mounted on a surface that will not flex when the hoist is in use, since this could bind the working parts of the hoist. Also, be sure the hoist is mounted on a flat surface. If necessary, use shim stock to insure proper mounting. The mounting surface must be flat within  $\pm 0.020$  inches (.5 mm).
5. Hydraulic lines and components that operate the hoist should be of sufficient size to assure minimum back pressure at the hoist motor ports. To insure adequate static brake load holding ability, back pressure on the hoist should not exceed 100 psi (690 kPa).
6. Make certain that the hoist drum is centered behind the first sheave and the fleet angle does not exceed  $1\frac{1}{2}$  degrees.  
The hoist should also be mounted perpendicular to an imaginary line from the center of the drum to the first sheave to ensure even spooling. (ref page 3)
7. The hoist directional control valve must be a three-position, four-way valve *without detents and with a spring centered motor spool* such that the valve returns to the centered position whenever the handle is released, and both work ports are opened to tank (open center, open port).

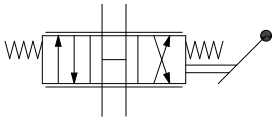

Recommended Control Valve Schematic

### ⚠ WARNING ⚠

**DO NOT** use a control valve with any detents or latching mechanism that would hold the control valve in an actuated or running position when the operator releases the control handle. Use of the wrong type of control valve could lead to unintentional operation of the hoist, which could result in property damage, personal injury or death.

8. The hydraulic oil filter should have a 10 micron nominal rating and be a full-flow type.
9. High quality hydraulic oil is essential for satisfactory performance and long hydraulic system component life.

Oil having 150 to 330 SUS viscosity at 100°F (38°C) and viscosity index of 100 or greater will give good results under normal temperature conditions. The use of an oil having a high viscosity index will minimize cold-start trouble and reduce the length of warm-up periods. A high viscosity index will minimize changes in viscosity with corresponding changes in temperature.

Maximum cold weather start-up viscosity should not exceed 5000 SUS with a pour point at least 20°F (11°C) lower than the minimum temperature.

Under continuous operating conditions the temperature of the oil at any point in the system must not exceed 180°F (82°C). 120-140°F (49-60°C) is generally considered optimum.

In general terms; for continuous operation at ambient temperatures between 50 and 110°F (10-43°C), use SAE 20W; for continuous operation between 10 and 90°F (-12 and 32°C), use SAE 10W; for applications colder than 10°F (-12°C), contact the BRADEN Product Support Department. The use of multi-viscosity oils is generally not recommended.

## WIRE ROPE INSTALLATION - (ONE PIECE CABLE WEDGE)

### ⚠ WARNING ⚠

**THE CABLE ANCHORS ALONE ON HOISTS ARE NOT INTENDED TO HOLD RATED LOADS.** Hoist loads applied directly to the wire rope anchor may cause the wire rope to pull free and result in the sudden loss of load control and cause property damage, personal injury or death. A minimum of 5 wraps of wire rope must be left on the drum barrel to achieve rated load.

The wedge and anchor pocket must be clean and dry. The end of the wire rope being anchored to the drum must be clean and dry and not frayed. Anything on the end of the wire rope to keep it from fraying (i.e. tape or

wire) must not be in contact with the wedge when the installation is complete. Consult the wire rope manufacturer on the proper treatment of the dead end of the wire rope. Some rope manufacturers recommend when using rotation resistant wire rope, that the rope end be seized, welded or brazed before inserting the wire rope into the wedge socket to prevent core slippage or loss of rope lay.

Take the free end of the wire rope and insert it through the small opening on the cable drum. Loop the wire rope and push the free end about 3/4 of the way back through the pocket. Install the wedge as shown in figure 1, then pull the slack out of the wire rope. The "dead" end of the rope needs to extend slightly beyond the end of the wedge as shown in figure 2.

Using a hammer and brass drift, drive the wedge deep into the pocket as possible to ensure it is fully seated and no further movement is detected. Applying a load on the wire rope will also help seat the wedge in the pocket.

Check to ensure the wedge does not protrude from either end of the pocket, causing it to interfere with proper spooling of wire rope onto the drum (see figures 3 & 4). If there is interference or the wedge does not

seat firmly, contact the Braden Product Support Department at 918-251-8511 to determine the proper wedge size.

It is important that the wire rope have the proper tensioning when it is installed on the drum. When the wire rope is first installed, you should operate the hoist, with light to moderate loads, with reeving that let's you place these loads on the block and the drum with all the rope off the drum except for the last five wraps.

### Correct Installation

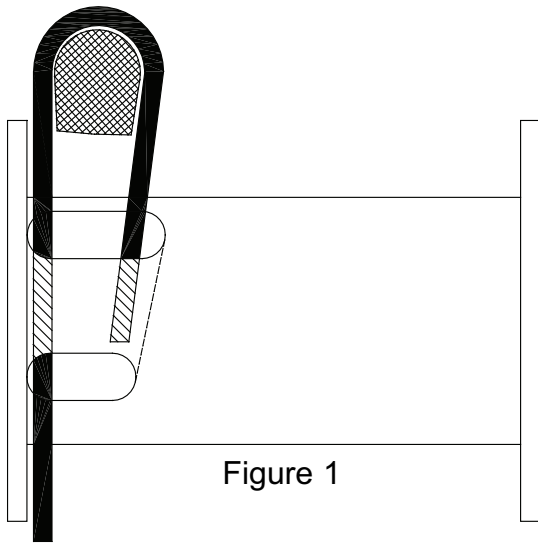

Figure 1

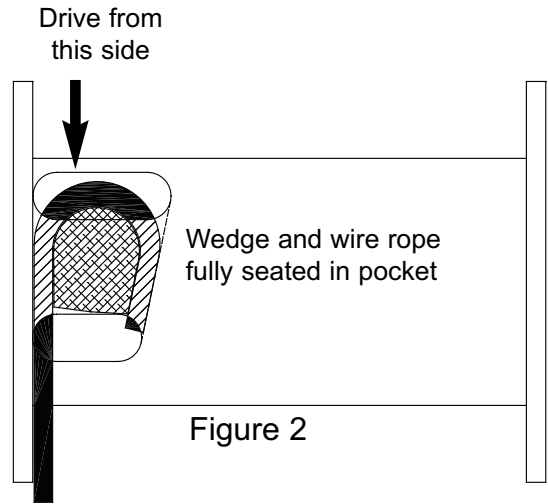
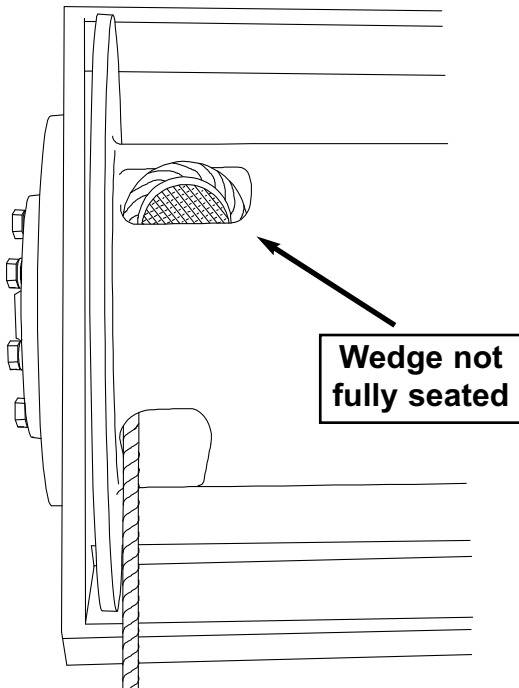

Figure 2

### Incorrect Installations



- Wire rope not tight against wedge
- Wedge may be too large

Figure 3

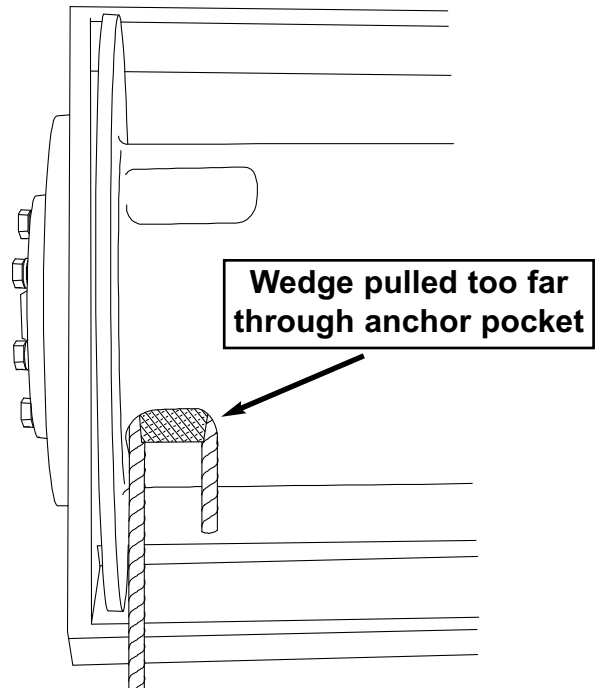

- “Dead” end of wire rope and/or wedge may interfere with proper spooling
- Wedge may be too small

Figure 4

# HOIST OPERATION

The following warnings and instructions are basic to safe hoist operation. Please read them carefully and follow them each time your hoist is operated. These instructions are provided in addition to any information furnished by the Original Equipment Manufacturer. Equipment operators should be completely familiar with the overall operation of the piece of equipment on which the hoist is mounted (i.e. crane, truck crane, etc.). If you have any questions concerning the safe operation of this hoist or the equipment it is mounted on, contact the equipment manufacturer that installed the hoist, or the Braden Product Support Department at 918-251-8511, Monday through Friday, 0800 to 1630 hours CST, by fax at (918) 259-1575, or via the internet at [www.paccarwinch.com](http://www.paccarwinch.com).

## **WARNING**

Ground personnel must stay in view of the operator and clear of the load and hoist drum at all times. Do not allow personnel near the hoist line under tension. Do not allow personnel near the hoist drum while the hoist is in operation. Do not allow personnel to be in line with the load. Do not allow personnel to stand under a suspended load. A safe distance of at least 1½ times the working length of the cable should be maintained by ground personnel. A broken cable and/or lost load may cause property damage, personal injury or death.

## **WARNING**

Failure to properly warm up the hoist, particularly under low ambient temperature conditions, may result in temporary brake slippage due to high back pressures attempting to release the brake, which could result in property damage, severe personal injury or death.

## **WARNING**

Failure to use the proper type and viscosity of planetary gear oil may contribute to intermittent brake clutch slippage which could result in property damage, severe personal injury or death. Some gear lubricants contain large amounts of EP (extreme pressure) and anti-friction additives which may contribute to brake slippage and damage to brake friction discs or seals. Oil viscosity with regard to ambient temperature is also critical to reliable brake operation. Our tests indicate that excessively heavy or thick gear oil may contribute to intermittent brake slippage. Make certain that the gear oil viscosity used in your hoist is correct for your prevailing ambient temperature.

### Warm-up Procedures

A warm-up procedure is recommended at each start-up and is essential at ambient temperatures below +40°F (4°C).

The engine should be run at its lowest recommended RPM with the hydraulic hoist control valve in neutral allowing sufficient time to warm up the system. The hoist should then be operated at low speeds, raise and lower, several times to prime all lines with warm hydraulic oil, and to circulate gear lubricant through the planetary gear sets.

## **CAUTION**

If the hoist is mounted on a crane that has an extendable boom, care must be taken to pay-out cable as the boom is extended. Failure to pay-out sufficient cable could result in a “two-blocking” condition that could result in damage to and/or failure of the hoist, cable, sheaves and/or boom.

After the hoist/boom is properly positioned, we recommend the operator slowly pay-out, then haul-in a short

length of cable. The hoist should perform these operations in a smooth and controlled manner. If the hoist does not operate smoothly or makes any unusual sounds, the source of the problem should be identified and corrected before any attempt is made to lift a load.

Slowly pay-out wire rope from the hoist drum until it reaches the load. Securely fasten the hoist cable to the load and be sure all ground personnel are a safe distance from the load. Slowly lift the load a short distance and stop. A small amount of “bounce” may be observed, depending on the weight of the load, size and type of wire rope, reaving and the amount of boom extension. Allow the load to stabilize and then watch for any sign of downward movement or cable drum rotation. The hoist static brake should hold the load in place without allowing any downward movement at all. If the load creeps down, it should be lowered to the ground immediately and the source of the problem identified and corrected.

If the hoist is holding the load securely, proceed with normal operations in accordance with the equipment manufacturer’s operating procedures and load charts.

# TYPICAL HYDRAULIC CIRCUIT

**NOTE:** The hydraulic circuit shown below is representative of typical Braden hoists. Options and accessory equipment may result in changes to the circuit shown. If there are any questions regarding the hydraulic circuit, refer to information supplied by the original equipment manufacturer, or contact the Braden Product Support Department at the number given in the Foreword of this manual. (ALWAYS have the hoist model and serial number when contacting the factory)

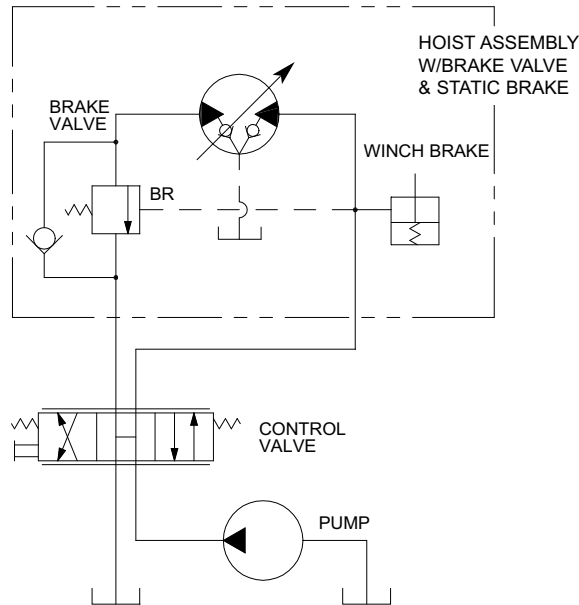

The general purpose fastener torque chart shown below applies to SAE Grade 5 and 8 capscrews, studs and nuts. Higher or lower torque values may be specified for special applications. The lubricated torque values are based on SAE 30W engine oil applied to the threads of black phosphate treated bolts and nuts. Zinc plated fasteners use the "lubricated" torque value.

## RECOMMENDED FASTENER TORQUE

Bolt Dia. Inches	Thds Per Inch	Torque (LB-FT)			
		Grade 5		Grade 8	
		Dry	Lubed	Dry	Lubed
1/4	20	8	6	12	9
	28				
5/16	18	17	13	24	18
	24				
3/8	16	31	23	45	35
	24				
7/16	14	50	35	70	50
	20				
1/2	13	75	55	110	80
	20				
9/16	12	110	80	150	110
	18				
5/8	11	150	115	210	160
	18				

Bolt Dia. Inches	Thds Per Inch	Torque (LB-FT)			
		Grade 5		Grade 8	
		Dry	Lubed	Dry	Lubed
3/4	10	265	200	380	280
	16				
7/8	9	420	325	600	450
	14				
1	8	640	485	910	680
	14				
1 1/8	7	790	590	1290	970
	12				
1 1/4	7	1120	835	1820	1360
	12				
1 3/8	6	1460	1095	2385	1790
	12				
1 1/2	6	1940	1460	3160	2370
	12				

# PREVENTIVE MAINTENANCE

A regular program of preventive maintenance for your planetary hoist is required to minimize the need for emergency servicing and promote safe, reliable hoist operation.

The user of Braden hoist products is responsible for hoist inspection, testing, operator training and maintenance noted below with frequency dependent upon the severity of the hoist duty cycle and the thoroughness of the preventive maintenance program.

Field experience, supported by engineering tests, indicate the three service procedures listed below are the most critical to safe, reliable hoist operation and **MUST** be observed.

- Regular Gear Oil Changes -
- Use of Proper Gear Oil – recommended type for prevailing ambient temperatures and additives.
- Periodic Disassembly and Inspection of All Wear Components – in compliance with ANSI specification B30.5c, 1987 and API RP 2D.

Crane inspection records as well as records of preventive maintenance, repairs and modifications must be available for a minimum of five (5) years. These records should include but not limited to, hoist model and serial number, name and employer of repair technician, date and description of work performed.

**Pre-use Inspection** (each shift the hoist is used): This inspection must be performed prior to placing the crane into service and then as necessary during the day for extended operation.

1. Check for external oil leaks and repair as necessary. **This is extremely important due to the accelerated wear that can be caused by insufficient lubricating oil in the hoist.** Lubricant level must be visible in the lower half of the sight glass. Use only recommended lubricants. See Recommended Lubricants chart in this manual.
2. Check hydraulic plumbing for damage, such as chafed or deteriorating hoses and repair as necessary.
3. Visually inspect for loose or missing bolts, pins, keepers or cotter pins and replace or tighten as necessary.
4. The gear oil should be changed after the first 100 hours of operation or 30 days. The regular gear oil change intervals may be adopted after the first oil change.
5. Inspect the full length of wire rope, rigging and all sheaves according to the wire rope and crane manufacturer's recommendations.
6. A warm-up procedure is recommended at each start-up and is mandatory at ambient temperatures below +40°F (4°C). The engine should be run at its lowest

RPM with the hydraulic hoist control in neutral allowing sufficient time to warm up the system. The hoist should then be operated at low speeds, hoisting and lowering with no load, several times to prime all hydraulic lines with warm oil and to circulate lubricant through the planetary gear sets.

## ! WARNING !

Failure to properly warm up the hoist, particularly under low ambient temperature conditions, may result in temporary brake slippage due to high back pressures attempting to release the brake, which could result in property damage, severe personal injury or death.

**Quarterly Inspection (every 3 months)** or monthly in Severe Duty Applications or prior to placing the machine in service if it has not been used for three months or more.

1. Perform the Pre-use Inspection.
2. Inspect all hoist fasteners for tightness and corrosion. Replace all corroded fasteners and tighten per the torque specifications on page 12.
3. The hydraulic system filters should be changed after the first 50 hours of operation then every 500 hours or quarterly or in accordance with the crane manufacturer's recommendations.
4. Take a sample of the gear oil from the hoist drum following the oil sampling procedure on page 15. The oil sample must be taken prior to changing the gear oil. Analyze the sample for wear metals, viscosity, signs of overheating, oxidation, water and other contaminants. If the oil sample contains an unusual amount of metallic particles, the hoist should be removed from service and undergo a tear-down inspection.

**Annual Inspection, Testing & Preventive Maintenance** or semi-annually in Severe Duty Applications.

1. Perform the Pre-Use and Quarterly Inspections.
2. Change the lubricating oil in the hoist drum after an oil sample is taken.

## ! WARNING !

The gear oil must be changed to remove wear particles that impede reliable and safe operation of the brake clutch and erode bearings and seals. Failure to change gear oil at recommended intervals may contribute to intermittent brake slippage, loss of load control, injury or death.

The gear oil should be changed whenever the ambient temperature changes significantly and an oil from a different viscosity range would be more appropriate. Oil viscosity is critical to reliable brake clutch operation. Our tests indicate that excessively heavy or thick gear oil may contribute to intermittent brake clutch slippage. Make certain the gear oil viscosity used in your hoist is correct for your prevailing ambient temperature.

**⚠ WARNING ⚠**

Failure to use the proper type and viscosity gear oil may result in loss of load control, property damage, injury or death.

**NOTE:** If the oil sampling/analysis has not been performed as required, tear-down inspections will be required. Refer to Hoist Disassembly section of this manual.

To change the gear oil, slowly rotate the drum until the oil drain plug is aligned with the lower oil port access hole. Install a short length of pipe threaded for 1 in. NPT into the threaded drain port in the cable drum. Reach through the pipe with a long hex-key and remove the drain plug. The oil will drain out the length of pipe and not between the drum and base. When the oil has drained, install the plug and remove the drain pipe. Removing the vent plug will hasten the oil drain. Rotate the drum until the drain port is aligned with the fill/level port in the end bracket. Refill the hoist with recommended lubricant. Install the plug securely.

3. The vent plug is located in the drum bearing support. It is important to keep the vent plug clean and unobstructed. Whenever the gear oil is changed, the vent plug should be removed, cleaned in solvent and reinstalled. Do not paint over the vent plug or replace with a solid plug or grease fitting.

**Recommended Planetary Gear Oil**

**⚠ WARNING ⚠**

Failure to use the proper type and viscosity of planetary gear oil may contribute to intermittent brake clutch slippage which could result in property damage, severe personal injury or death. Some gear lubricants contain large amounts of EP (extreme pressure) and anti-friction additives which may contribute to brake slippage and damage to brake friction discs or seals. Oil viscosity with regard to ambient temperature is also critical to reliable brake operation. Our tests indicate that excessively heavy or thick gear oil may contribute to intermittent brake slippage. Make certain that the gear oil viscosity used in your hoist is correct for your prevailing ambient temperature.

For simplicity, Braden has listed available products in each temperature range that have been tested and found to meet our specifications. This is not to say that other lubricant brands would not perform equally as well.

If the following lubricant brands are not available in your area, make certain your lubricant vendor supplies you with oil that is equivalent to those products listed below.

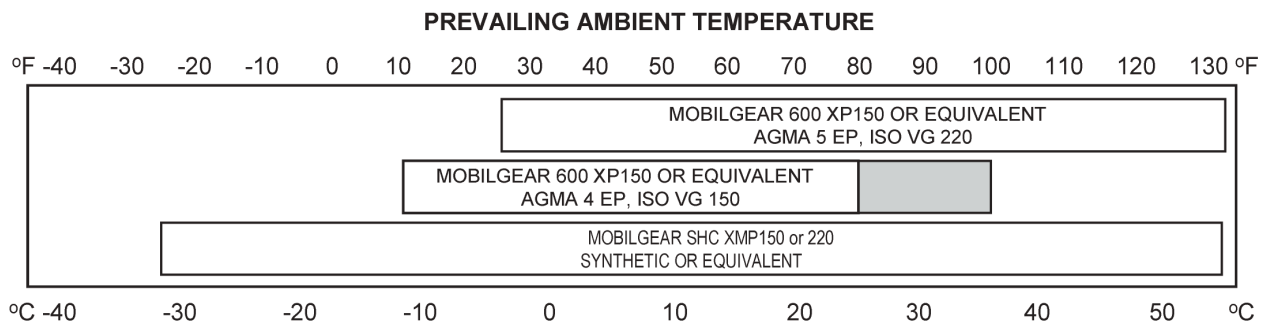

**i** **NOTE:** SHADED TEMPERATURE RANGE IN THE CHART ABOVE NOT RECOMMENDED FOR SEVERE APPLICATIONS SUCH AS: OFFSHORE CRANES, SUSTAINED FAST DUTY CYCLES OR FREQUENT LIFTING.

Planetary hoists are factory filled with Mobilgear 600 XP 150, or equivalent. Consult your oil supplier for other equivalent oils if required.

Mobil	Shell	Chevron	Texaco
Mobilgear 600 XP 150	Omala 150	Gear Compounds EP 150	Meropa 150
Mobilgear 600 XP 220	Omala 220	Gear Compounds EP 220	Meropa 220

## Tear-down Inspection

Any hoist that has not been subjected to regular oil sample analysis should undergo a tear-down inspection every 24 months. Also, if a hoist has an unknown history of repair and/or maintenance, the hoist should undergo a tear-down inspection prior to being placed into service.

A tear-down inspection of the hoist should include the complete disassembly, cleaning, inspection and replacement of all worn, cracked, corroded or distorted parts such as pins, bearings, shafts and brake components. All seals and o-rings should be replaced during a tear-down inspection. Always use new Spirol pins in the planet gear shafts.

## Any deficiency must be corrected immediately.

Before placing the hoist back in service, the rebuilt hoist must be pull tested to the rated load of the hoist with a dynamometer or equivalent measuring device. The hoist should be dynamically tested by rotating the drum several times, in both raising and lowering directions, while under load of at least 30% of the hoist rated lifting capacity. Check for smooth, quiet operation during this procedure.

---

# OIL SAMPLING AND ANALYSIS

Proper oil sampling and analysis of the sample, is a vital part of a comprehensive preventive maintenance program. Information obtained from the oil analysis is best utilized in conjunction with a regular program of preventive maintenance. The early warning of abnormal wear provided by an analysis program allows the user to substitute preventive maintenance for a far more costly and dangerous failure that may lead to loss of load control that could result in property damage, personal injury or death. Early detection of accelerated component wear allows the scheduling of corrective maintenance and can reduce in-operation failures and costly down time.

## Taking a Valid Oil Sample

Prepare the hoist by cleaning the drain area and drain extension tube in order to obtain an uncontaminated sample. Operate the hoist in both directions for one to two minutes and then take the oil sample from the drain port as soon as possible. Do not take the sample from the first oil out of the drain port. Take a sample from the mid-stream flow of the oil to obtain an accurate representation of the oil condition. After taking an oil sample, refill hoist with recommended lubricant.

## **WARNING**

Hot oil may cause personal injury and/or burns to unprotected skin. Make certain the oil has cooled to a safe temperature (less than 110°F or 43°C) before taking an oil sample, changing oil or servicing the hoist.

## Analysis

### General Guide Lines

(After approximately 250 hours of operation)

**Note:** *The first oil change usually contains more “wear metals”. Following the initial break-in period, the wear metal levels should stabilize at a lower number.*

### Iron Contaminates

100 to 500 ppm    Normal

501 to 800 ppm    Caution – Abnormal Sample (monitor more frequently), tear-down inspection may be required.

801 ppm & up    Unacceptable – Abnormal Sample (tear down inspection required)

In all contaminate monitoring, equally important as the level of contamination, is the change in the amount of contamination compared to previous samples.

Moisture contamination will lead to the formation of acids that damage all internal components. Silica found in the oil typically indicates “dirt” and contaminated lubricant supply or poor maintenance practices.



# TROUBLESHOOTING

The following troubleshooting section is provided as a general guide. You may also need to contact the Original Equipment Manufacturer (OEM) for additional information.

## ⚠ WARNING ⚠

If a hoist exhibits any sign of:

- Erratic operation such as poor load control, load creeping down or chattering.
- Unusual noise.
- Gear oil leaks.
- A sudden rise in wear particles from oil analysis

The hoist **MUST** be removed from service until the problem has been corrected. If a hoist has been subjected to a sudden heavy load (shock-load) or overload, the hoist must be removed from service, disassembled and all internal components thoroughly inspected for damage. Continued operation with a defect may result in loss of load control, property damage, injury or death.

TROUBLE	PROBABLE CAUSE	REMEDY
<p style="text-align: center; margin: 0;"><b>A</b></p> <p>The hoist will not lower the load or not lower the load smoothly.</p>	<ol style="list-style-type: none"> <li>1. The problem could be a plugged or loose pilot orifice. The pilot orifice is a small pipe plug with a hole drilled through it, located behind the pilot port fitting on the brake valve. If it becomes plugged, it will prevent the pilot pressure, from the manifold, from opening the brake valve. If it becomes loose, it will allow an unregulated amount of oil in to operate the brake valve which cause erratic brake valve operation.</li>   <li>2. The friction brake may not be releasing as a result of a defective brake cylinder seal.</li>   <p style="margin: 0;"><i><b>NOTE:</b> If the brake cylinder seal is defective you will usually find oil leaking from the hoist vent plug.</i></p>   <li>3. Friction brake will not release as a result of damaged brake discs.</li> </ol>	<p>Remove the pilot hose and fitting from the brake valve, then use a 5/32 inch Allen wrench to remove the pilot orifice. The diameter of the orifice is approximately .020 inches (.5 mm). Clean and install the pilot orifice tightly in the brake valve.</p> <p>Check brake cylinder seal as follows:</p> <ol style="list-style-type: none"> <li>A. Disconnect the swivel tee from the brake release port. Connect a hand pump with accurate 0-2000 psi (13,800 kPa) gauge and shut-off valve to the fitting in the brake release port.</li> <li>B. Apply 1000 psi (6,900 kPa) to the brake. Close shut-off valve and let stand for five (5) minutes.</li> <li>C. If there is any loss of pressure in five (5) minutes, the brake cylinder should be disassembled for inspection of the sealing surfaces and replacement of the seals. Refer to "Brake Cylinder Service" section of this manual.</li> </ol> <p>Disassemble brake to inspect brake discs. Check stack-up height as described in "Brake Cylinder Service" section of this manual.</p>

TROUBLE	PROBABLE CAUSE	REMEDY
<p style="text-align: center;"><b>B</b></p> <p>Oil leaks from vent plug.</p>	<ol style="list-style-type: none"> <li>1. Same as A2.</li> <li>2. Motor seal may be defective as a result of high back pressure in the motor case drain circuit or contaminated oil.</li> </ol>	<p>Same as A2.</p> <p>Case drain back pressure must not exceed 70 psi (480 kPa). Inspect hydraulic system for a restriction in the return line to the reservoir.</p> <p>Oil analysis may indicate contamination has worn motor shaft and seal. Thoroughly flush entire hydraulic system and install new filters and oil. Install new motor seal.</p>
<p style="text-align: center;"><b>C</b></p> <p>The brake will not hold a load with the control lever in neutral.</p>	<ol style="list-style-type: none"> <li>1. Excessive system back pressure acting on the brake release port.</li> <li>2. Friction brake will not hold due to worn or damaged brake discs.</li> <li>3. Brake clutch is slipping.</li> </ol>	<p>The pressure at the motor lowering port is also transmitted to the brake release pilot circuit. Inspect hydraulic circuit for restrictions, plugged filters or control valves not centering.</p> <p>Same as Remedy of Trouble A3.</p> <p>Improper planetary gear oil may cause the brake clutch to slip. Drain old gear oil and flush winch with solvent. Thoroughly drain solvent and refill hoist with recommended planetary gear oil listed in "Preventive Maintenance".</p> <p>Brake clutch may be damaged or worn. Disassemble and inspect brake clutch as described in "Over-running Clutch Service".</p>
<p style="text-align: center;"><b>D</b></p> <p>The hoist will not hoist the rated load</p>	<ol style="list-style-type: none"> <li>1. The hoist may be mounted on an uneven or flexible surface which causes distortion of the hoist base and binding of the gear train. Binding in the gear train will absorb horsepower needed to hoist the rated load and cause heat.</li> <li>2. System relief valve may be set too low. Relief valve needs adjustment or repair.</li> </ol>	<p>Reinforce mounting surface.</p> <p>If necessary, use shim stock to level hoist. Refer to "Hoist Installation".</p> <p>First loosen, then evenly retighten all hoist mounting bolts to recommended torque.</p> <p>Check relief pressure as follows:</p> <ol style="list-style-type: none"> <li>A. Install an accurate 0-5000 psi (34,500 kPa) gauge into the inlet port of the brake valve.</li> </ol>

TROUBLE	PROBABLE CAUSE	REMEDY
TROUBLE "D" CONTINUED FROM PREVIOUS PAGE	<p>3. Be certain hydraulic system temperature is not more than 180°F (82°C). Excessive hydraulic oil temperatures increase motor internal leakage and reduces motor performance.</p> <p>4. Hoist line pull rating is based on 1<sup>st</sup> layer of wire rope.</p> <p>5. Rigging and sheaves not operating efficiently.</p>	<p>B. Apply a stall pull load on the hoist while monitoring pressure.</p> <p>C. Compare gauge reading to hoist specifications. Adjust relief valve as required.</p> <p><b>NOTE:</b> <i>If pressure does not increase in proportion to adjustment, relief valve may be contaminated or worn out. In either case, the relief valve may require disassembly or replacement.</i></p> <p>Same as remedies for Trouble D1 &amp; D2.</p> <p>Same as remedies for Trouble E2.</p> <p>Refer to hoist performance charts for additional information.</p> <p>Perform rigging service as recommended by crane manufacturer.</p>
<p><b>E</b></p> <p>The winch runs hot.</p>	<p>1. Same as D1.</p> <p>2. Be certain that the hydraulic system temperature is not more than 180°F (82°C). Excessive hydraulic oil temperatures may be caused by:</p> <p>A. Plugged heat exchanger.</p> <p>B. Too low or too high oil level in hydraulic reservoir.</p> <p>C. Same as D2</p> <p>D. Hydraulic pump not operating efficiently.</p> <p>E. Hydraulic oil is wrong viscosity for operating conditions.</p> <p>3. Excessively worn or damaged internal winch parts.</p>	<p>Same as remedies for Trouble D1.</p> <p>Thoroughly clean exterior and flush interior.</p> <p>Fill/drain to proper level.</p> <p>Same as remedies for Trouble D2.</p> <p>Engine low on horsepower or R.P.M. Tune/adjust engine.</p> <p>Check suction line for damage.</p> <p>Pump worn. Replace pump.</p> <p>Use correct hydraulic oil.</p> <p>Disassemble hoist to inspect/replace worn parts.</p>

TROUBLE	PROBABLE CAUSE	REMEDY
<p style="text-align: center;"><b>F</b></p> <p>Hoist “chatters” or surges while raising rated load.</p>	<ol style="list-style-type: none"> <li>1. Same as D2.</li> <li>2. Hydraulic oil flow to motor may be too low.</li> <li>3. Controls being operated too quickly.</li> <li>4. Hydraulic motor 2-speed control not shifting correctly.</li> </ol>	<p>Same as remedies for Trouble D2.</p> <p>Same as remedies for Trouble E2.</p> <p>Conduct operator training as required.</p> <p>Inspect and repair motor displacement control.</p>
<p style="text-align: center;"><b>G</b></p> <p>The wire rope does not spool smoothly on the drum.</p>	<ol style="list-style-type: none"> <li>1. The hoist may be mounted too close to the main sheave, causing the fleet angle to be more than 1½ degrees.</li> <li>2. The hoist may not be mounted perpendicular to an imaginary line between the center of the cable drum and the first sheave.</li> <li>3. Could possibly be using the wrong lay rope. There is a distinct advantage in applying rope of the proper direction of lay. When the load is slacked off, the several wraps on the drum will stay closer together and maintain an even layer. If rope of improper lay is used, the coils will spread apart each time the load is removed. Then, when hoisting is resumed, the rope has a tendency to criss-cross and overlap on the drum. The result is apt to be a flattened and crushed rope.</li> <li>4. The hoist may have been overloaded, causing permanent set in the wire rope.</li> </ol>	<p>Check mounting distance and fleet angle. Reposition hoist as required to achieve ½ to 1½ degree fleet angle.</p> <p>Refer to “Hoist Installation”.</p> <p>Consult wire rope manufacturer for recommendation of wire rope that best suits your application.</p> <p>Replace wire rope and conduct operator/rigger training as required.</p>
<p style="text-align: center;"><b>H</b></p> <p>Sensor does not read drum rotation properly.</p>	<ol style="list-style-type: none"> <li>1. Sensor may need to be adjusted.</li> <li>2. Sensor may not have correct supply voltage.</li> <li>3. Sensor may be defective.</li> </ol>	<p>Rotate drum slowly.</p> <p>A. If sensor light stays on, loosen lock nuts and slowly turn the sensor CCW until sensor light blinks on and off. Continue turning sensor 1/4 to 1/2 CCW after light blinking starts and tighten lock nuts until snug to avoid damage to the sensor.</p> <p>B. If sensor light does not come on or blink, loosen locknuts and slowly turn the sensor CW until sensor light blinks on and off. Continue turning sensor 1/4 to 1/2 CW after light blinking starts and tighten locknuts until snug to avoid damage to sensor.</p> <p>Test voltage at sensor plug, pin1, brown wire. Voltage must be 9-24 volts DC. If voltage is too low or 0 volts, test electrical harness for open circuit.</p> <p>Replace sensor. Adjust sensor as described above in H1.</p>

# DISASSEMBLY PROCEDURE

1. Remove the wire rope from the drum and wind onto a cable reel as recommended by the wire rope manufacturer. Power wash the hoist and all motor piping to remove contamination that might enter open hose and motor ports. Drain the gear oil from the hoist as described in the Preventive Maintenance section of this manual.

## CAUTION

The GHP30 hoist weighs approximately 1435 lb. (650 kg). Make certain lifting equipment has adequate capacity. Using undersized or poorly maintained lifting equipment may result in a dropped load, property damage, injury or death.

2. Remove the cable guard roller and cable tension roller group. Stand the hoist up on the drum bearing support end with the motor end up. Secure the hoist in this position so that it does not fall over and cause property damage or personal injury.
3. Tag and remove the hydraulic hoses that connect the brake valve and motor manifold to the brake release port.
4. Remove the four capscrews and lockwashers securing the motor and lift the motor off the hoist. Cover the motor ports to prevent contamination. Remove the brake clutch assembly from the brake cylinder. Disassembly of the brake clutch assembly will be discussed in the "Brake Clutch Service" section of this manual.
5. Remove the eight capscrews that secure the brake cylinder to the motor side plate. Lift the brake cylinder out of the hoist and place on a clean work surface. Disassembly of the brake cylinder will be discussed in the "Brake Cylinder Service" section of this manual.
6. Loosen the jam nut then remove the drum rotation sensor from the motor side plate to prevent damage to the sensor. Remove the ten capscrews that secure the motor side plate to the base and lift the side plate off the hoist drum.
7. Install two ½ in. NC lifting eyes into the tapped holes in the drum closure and lift the closure out of the drum.
8. Remove the output planetary carrier assembly from the drum.

9. Grasp the input sun gear shaft and lift the input planetary carrier assembly from the drum.

## CAUTION

The cable drum weighs approximately 350 lb. (160 kg). Make certain lifting equipment has adequate capacity. Using undersized or poorly maintained lifting equipment may result in a dropped load, property damage or personal injury.

10. Lift the cable drum off the drum bearing support and endplate assembly.
11. Thoroughly clean and inspect all components at this time.
  - a. The drum bearings should roll freely and smoothly. If they sound rough, clean again in solvent, blow dry and inspect once more. If they still sound rough, replace them.
  - b. Inspect sealing and bearing surfaces on drum bearing support and brake cylinder for damage that may prevent long seal and bearing life. If damaged, replace or repair the components as required.
  - c. Inspect the ring gear teeth for nicks, pitting or excessive wear. To check for wear, place a straight edge along the teeth such that the straight edge spans from an unworn area, over a worn area and again is supported by an unworn area. Place feeler gauges under the straight edge to measure the depth of the wear. If a small ridge has been pushed up at the edge of the worn area, you must first file down the ridge with a flat mill file that spans across the worn area as described for the straight edge. Replace the ring gear if the wear in the gear contact area is greater than .015 in. (.38 mm) when compared to the unworn area of the teeth.
  - d. Conduct Magnetic Particle Inspection (MPI) of the planet gears to check for any small stress cracks that may not be visible to the naked eye. Discard the gears if ANY cracks are found.

# PLANETARY CARRIER SERVICE

## Disassembly

1. With a pin-punch, drive the spirol pins into the planet gear shafts until the spirol pins clear the planetary carrier. Slide the planet gear shafts out of the carrier far enough to allow access to the drive the spirol pins out of the shafts.

### **! WARNING !**

Do not reuse spirol pins. Their resistance to movement is reduced with reuse. Reusing spirol pins may result in a pin moving out of the planet gear shaft and carrier which may lead to misaligned gears, foreign object damage to the gear train and catastrophic gear train failure. Gear train failure may result in loss of load control, property damage, injury or death.

2. Finish removing the planet shafts, gears, bearing rollers and thrust washers from the planet carrier. Thoroughly clean all parts and inspect for damage and wear.
  - The bearing rollers should not exhibit any irregularities. If the rollers show any sign of pitting, corrosion or discoloration the rollers must be replaced. If replacing one roller, then ALL the rollers must be replaced.
  - The gear teeth wear surface must be smooth and free of any pitting or uneven wear. The bearing roller contact surfaces inside the gear must be smooth and free of pitting, scoring or discoloration. If the gear shows any abnormal signs, the gear must be replaced.
  - The planet gear shafts must be smooth and free of any pitting, uneven wear or discoloration. If the shafts show any abnormal signs, the shaft must be replaced.

## Assembly

1. Place the planetary carrier on a clean work surface with the splined collar facing up.
2. Apply a liberal coat of oil-soluble grease, such as Lubriplate 105, to a thrust washer and center the washer on one side of a planet gear. Place the planet gear on a clean surface with the thrust washer down. Apply a liberal coat of oil-soluble grease in the bore of the gear then stack a row of bearing rollers into the planet gear, using the grease to hold the rollers in position. There are 19 rollers in each primary planet gear and two rows of 19 rollers separated by a spacer ring in the output planet gears. Place a second thrust washer on top of the planet gear. Carefully slide the planet gear with, bearing rollers and thrust washers into the carrier. Install the planet gear shaft taking care to align the roll-pin hole with the roll-pin hole in the carrier.

### **! WARNING !**

The planet gear shafts will pass easily through the planet gear bearing rollers and thrust washers with only a slight amount of drag. If there is any binding, STOP and realign the rollers and thrust washers. DO NOT drive the planet gear shafts into the carrier with a hammer as damage to the thrust washers and bearing rollers may result. Damaged gear train components may cause a catastrophic gear train failure that may lead to loss of load control, property damage, injury or death.

3. Install NEW spirol pins into the carrier and planet gear shafts. Drive the spirol pin, far enough into the planetary carrier to equally engage the shaft and the planet carrier. The outer end of the spirol pin should be recessed approximately 1/32 in. (1 mm) in the primary planetary carrier and recessed approximately 1/16 in. (2 mm) in the output planetary carrier. With a center punch, deform (stake) the outer edge of the planetary carrier next to the spirol pin to prevent the pin from backing out.
4. Repeat this assembly procedure for the remaining planet gears.

**(See the following page for illustrations)**

## Output Planet Carrier Assembly

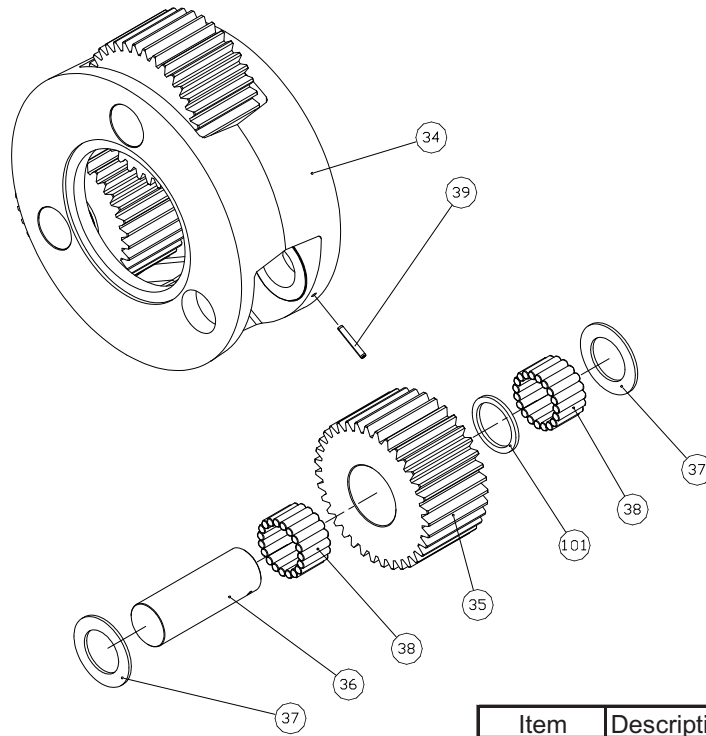

Item	Description	Quantity
34	Output Planetary Carrier	1
35	Output Planet Gear	3
36	Output Planet Gear Shaft	3
37	Thrust Washer	6
38	Bearing Rollers	114
39	Spirol Pin	3
101	Bearing Spacer	3

Item	Description	Quantity
26	Primary Planetary Carrier	1
27	Primary Planet Gear	3
28	Primary Planet Gear Shaft	3
29	Thrust Washer	6
30	Bearing Rollers	57
31	Spirol Pin	3
57	Output Sun Gear	1
147	Retaining Ring	1

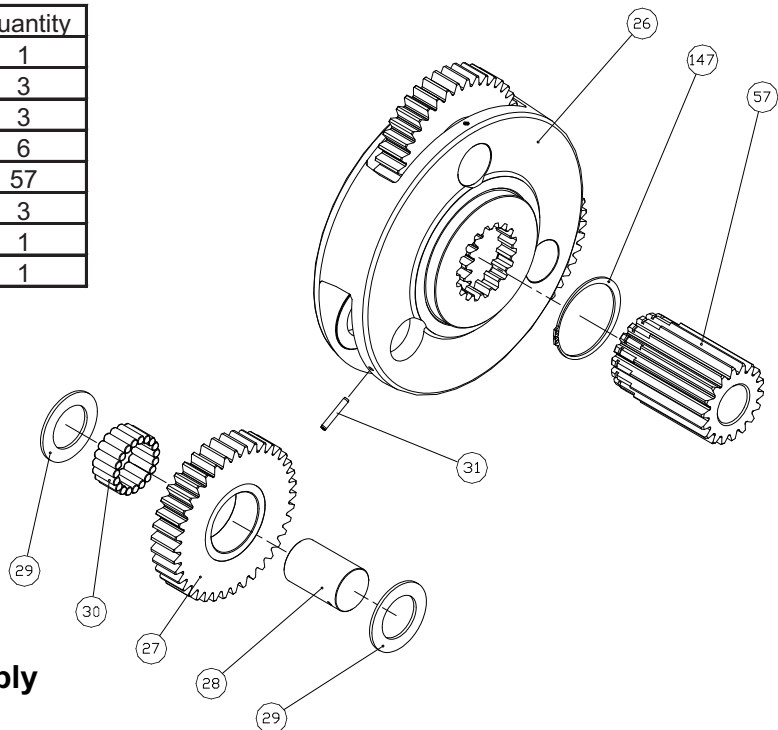

## Primary Planetary Carrier Assembly

# OVER-RUNNING CLUTCH SERVICE

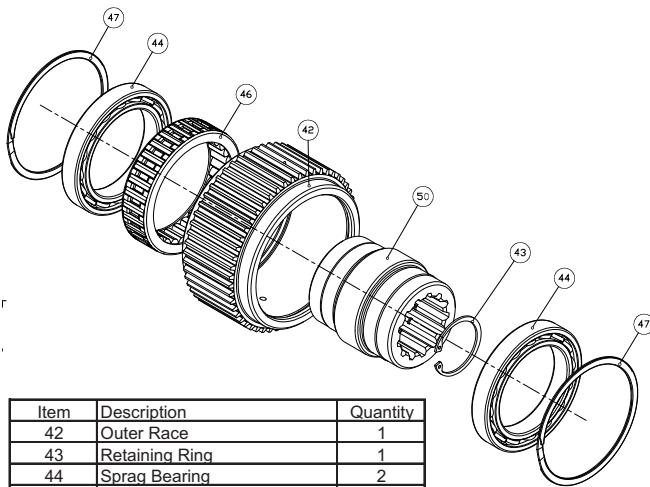

Item	Description	Quantity
42	Outer Race	1
43	Retaining Ring	1
44	Sprag Bearing	2
46	Sprag Clutch	1
47	Retaining Ring	2
50	Inner Race	1

**NOTE:** Outer race (item 42), Inner race (item 50) and Over-running clutch (item 46) are NOT SOLD individually as replacement parts. If any of these parts require replacement, the entire over-running clutch assembly must be replaced. Carefully note the relative orientation between the inner and outer races, and the direction of free rotation of the inner race. The clutch MUST be re-assembled correctly for proper hoist operation.

## ⚠ WARNING ⚠

The polished surfaces of the inner and outer race and the over-running cams must be perfectly smooth to insure positive engagement of the clutch. The slightest defect may reduce clutch effectiveness, which may lead to loss of load control and result in property damage, injury or death. It is generally recommended to replace the entire clutch assembly if any component is defective. For these reasons, the over-running clutch assembly should be disassembled for inspection only if the hoist has exhibited any unusual operation that would point toward a clutch malfunction, or the over-running clutch assembly shows external signs of mechanical damage.

## Disassembly

1. Use a paint pen to mark the corresponding ends of the inner race (50), outer race (42) and the over-running clutch (46). The marks will aid reassembly. Remove one retaining ring (47) from the outer race (42). Carefully push the inner race (50) through the outer race (42) toward the end the retaining ring was removed from. The inner race will bring with it the roller bearing (44) from that end.
2. Use a non-marring brass punch and a small hammer

to carefully tap the remaining bearing (44) out of the outer race (42). The over-running clutch (46) may be removed from the inner race. Closely inspect the polished surfaces of the over-running clutch cams and the races. Check for wear, scoring, pitting or heat discoloration. Closely inspect the roller bearings for signs of damage, pitting or heat discoloration. If there is any imperfection in these parts, they must be replaced.

## Assembly

## ⚠ WARNING ⚠

Failure to assemble the over-running clutch assembly with all parts oriented correctly may result in reduced brake effectiveness, which may lead to loss of load control and result in property damage, injury or death.

1. If both bearings (44) have been removed from the outer race, install one bearing onto the inner race (50).
2. Install the over-running clutch (46) onto the inner race (50), be certain of the freewheel direction. The long shoulder end of the outer race faces toward the hydraulic motor.
3. Install the internal retaining ring (43) into the inner race (50). Install the inner race (50) and the over-running clutch (46) into the outer race (42) by slowly rotating the inner race in the free-wheel direction as you gently push the cams into the outer race. The internal retaining ring should be located toward the hoist gear train and away from the hydraulic motor. This offset provides room for the splined motor shaft.
4. Install the remaining bearing (44) and retaining ring (47). Make certain all retaining rings are fully seated in the grooves. Apply a liberal amount of hoist gear oil to the over-running brake clutch assembly before installing into a hoist.

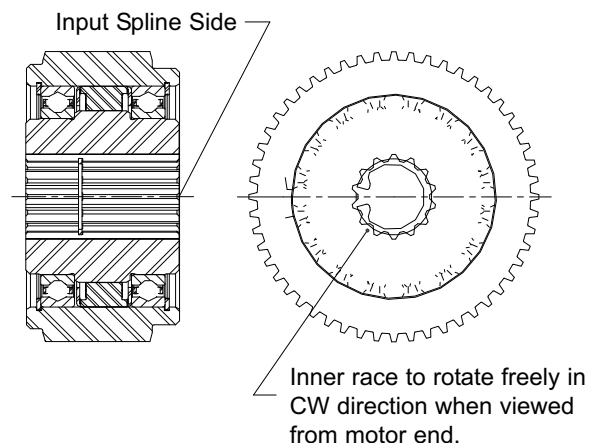



# BRAKE CYLINDER SERVICE

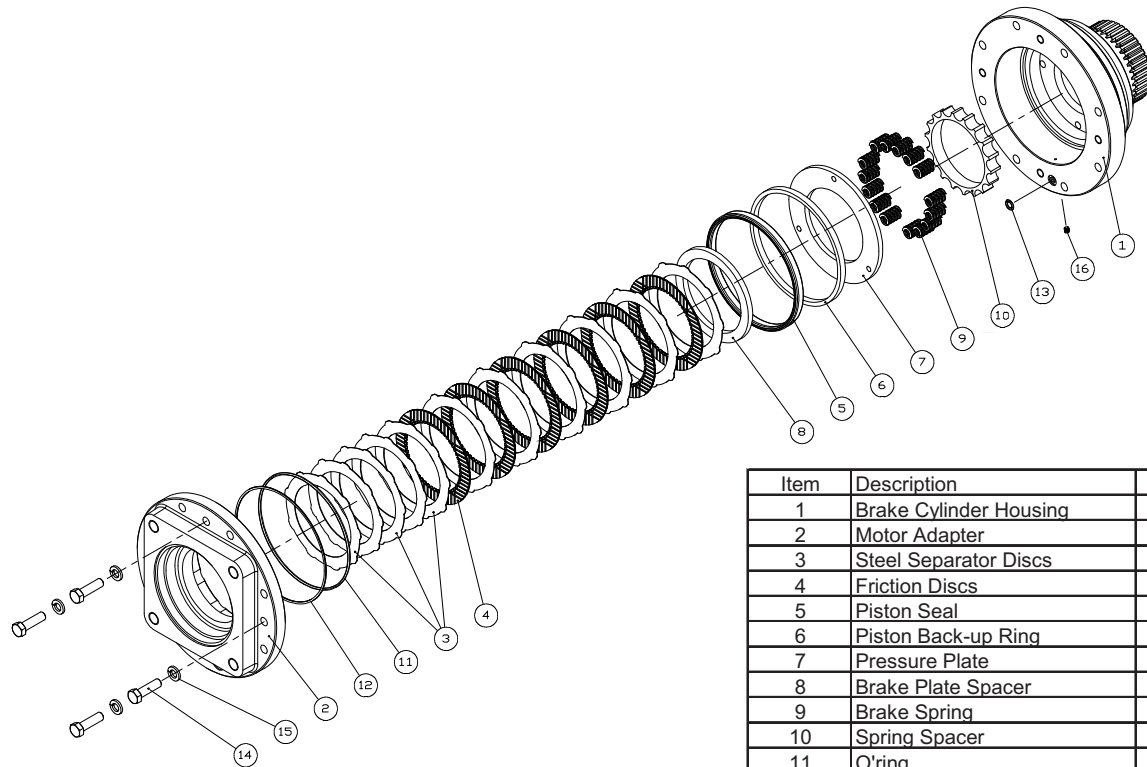

Item	Description	Quantity
1	Brake Cylinder Housing	1
2	Motor Adapter	1
3	Steel Separator Discs	11
4	Friction Discs	6
5	Piston Seal	1
6	Piston Back-up Ring	1
7	Pressure Plate	1
8	Brake Plate Spacer	1
9	Brake Spring	15
10	Spring Spacer	1
11	O'ring	1
12	Back-up Ring	1
13	O'ring	1
14	Capscrew	4
15	Lockwasher	4
16	Expansion Plug	1

## Disassembly



**CAUTION**  
The motor adapter is under spring tension from the brake springs. Loosen each of the capscrews one turn at a time until spring tension is released.

The brake cylinder assembly is secured to the hoist end-plate by eight 1/2 -13 X 3 capscrews. The remaining four 1/2 - 13 X1 3/4 capscrews (14) located at 3, 6, 9, and 12 o'clock positions, hold the motor adapter (2) to the cylinder (1) and compress the brake springs (9).

1. Place the brake cylinder assembly on a clean work surface with the splined end down. Evenly remove the four capscrews (14) and washers (15). Use a cross pattern when loosening the capscrews one turn at a time until the spring tension is released.
2. Remove the motor adapter (2) and lift out the brake discs (3 & 4) and the spacer (8).
3. Remove the o-ring and back-up ring (11,12) from the motor adapter. Remove the seal (5) from the cylinder (1). Remove the steel piston back-up ring (6) from the cylinder.
4. Remove the pressure plate (7) and the springs (9) and spring spacer (10).

## Clean and Inspect

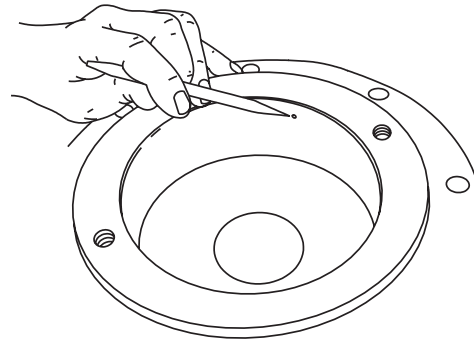

1. Thoroughly clean all the brake cylinder parts at this time. Check sealing surfaces on both the cylinder and the motor adapter. Be sure the brake release port is clean.

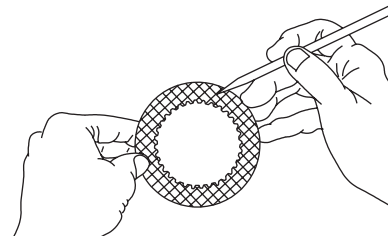

2. Place the friction discs (4) on a flat surface and check for distortion with a straight edge. The friction

material must appear even across the entire surface with a groove pattern visible. Replace the friction discs if the splines are worn to a point, the disc is warped, burned or worn unevenly. The minimum groove depth is .003 in. (.08 mm).

- Place the steel separator discs (3) on a flat surface and check for distortion with a straight edge.
- Inspect the surfaces for signs of material transfer or excessive heat. Replace the disc if distorted, heat discolored or mechanically damaged.

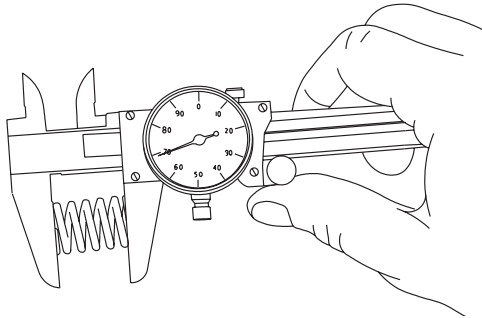

- Measure the brake spring free length. The minimum free-length is 1 7/16 in. (36.5 mm). Inspect the springs for any signs of cracking or fatigue. If a spring must be replaced for any reason, then ALL the springs must be replaced to ensure even brake application force.

**⚠ CAUTION ⚠**

Failure to replace brake springs as a set may result in uneven brake application pressure and repeated brake spring failure.

## Assembly

- Place the motor adapter (2) on a clean work surface with the motor side facing down. Apply a light coat of hoist gear oil to the new brake piston seal (5) and install the seal onto the adapter with the sealing lip edge toward the motor. Install the o-ring and back-up ring (11, 12) onto the motor adapter with the back-up ring toward the motor. The cupped surface of the back-up ring (12) must face toward the o-ring.
- Install a steel brake separator disc (3) into the motor adapter followed by a friction disc (4). Continue to alternately install steel and friction discs until there are 11 steel and 6 friction discs. Finish with 5 steel discs on top.
- Install the brake plate spacer ring (8) on top of the last steel brake disc.

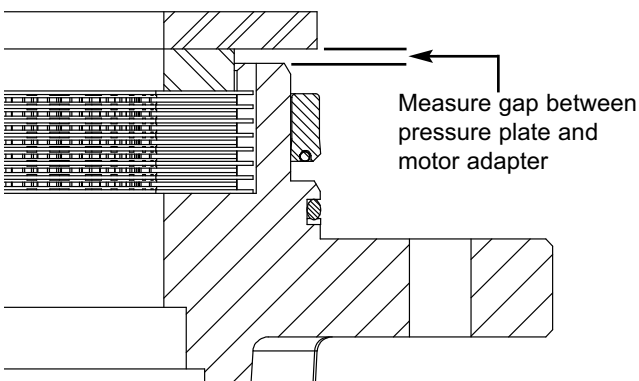

- To check brake stack height, place pressure plate (7) on top of brake spacer. Hold pressure plate down firmly by hand and measure gap (in three

places) between motor adapter and pressure plate. Average gap must measure between 0.160 in. (4 mm) maximum and 0.080 in. (2.0 mm) minimum. If the gap exceeds the maximum limit, there may be too many discs in the stack-up or the discs are distorted. If the gap is less than the minimum, there may be too few discs or the discs are worn beyond their serviceable limit and should be replaced. When the gap is within the minimum and maximum values, remove the pressure plate and all brake discs. Lubricate all friction discs with the same oil to be used in the hoist. Install all brake discs and brake plate spacer as described in steps 2 and 3.

- Place the brake cylinder on a clean work surface with the splined end down. Install the spring spacer (10), then the 15 springs (9).

**⚠ WARNING ⚠**

Always use the molded spring spacer to properly position the springs in the brake cylinder. Failure to install the spring spacer may allow the springs to contact each other and become damaged. This could result in loss of load control, property damage, injury or death.

- Install the pressure plate (7) into the brake cylinder. Be careful that none of the springs fall over. Install the steel backup ring (6). Apply petroleum jelly or an oil soluble grease to a new O-Ring (13) and install it in the brake cylinder.

**NOTE:** *The close fitting piston backup ring (6) may be depressed slightly to one side to lodge it in the brake cylinder bore and temporarily hold the pressure plate and springs in place while the brake cylinder is inverted and lowered over the motor adapter.*

*As an alternate, the motor adapter and brake plates can be turned over and installed into the brake cylinder, holding the brake plates and spacer in place through the center opening. Be careful to not pinch your fingers between the spacer plate and the pressure plate.*

7. Apply petroleum jelly or an oil soluble grease to the sealing surface of the brake cylinder and the piston seal. Turn the brake cylinder over and lower it onto the motor adapter, being careful not to damage the piston seal or O-Ring on the adapter. Be careful the O-Ring (13) does not fall out of place, and the oil passages are aligned. The alternate assembly method above could also be used.
8. Turn the entire assembly over and install the four capscrews and lockwashers. After the capscrews make contact with the motor adapter, evenly tighten them one turn at a time until the motor adapter is drawn tight against the brake cylinder, then torque to the recommended value.

## **BRAKE CYLINDER PRESSURE TEST**

1. Install a -6 ORB fitting into the brake release port on the motor adapter. Connect a hand pump with an accurate 0-2,000 psi (0-13,800 kPa) gauge and shut-off valve to this fitting. Apply 1,000 psi (6,900 kPa) to the brake and close the shut-off valve. Let the unit stand for five minutes. If there is any loss of pressure, the brake cylinder should be disassembled for inspection of the sealing surfaces, seal and O-Ring. When the source of the pressure leak has been determined and corrected, re-assemble the brake cylinder and repeat the test.
2. **WHILE PRESSURE IS APPLIED AND THE BRAKE IS RELEASED**, install the over-running clutch assembly into the brake pack. Turn the clutch back and forth to align the splines on all the friction discs. Release the pressure on the brake cylinder and remove the clutch assembly. The brake cylinder is now complete and ready to be installed in the hoist.

# HOIST ASSEMBLY

(Refer to illustration on page 8)

1. Thoroughly clean the machined surfaces of the cast base (61). Make sure the tapped holes, end plate and bottom mounting surfaces are free of paint and rust. Place the base on a clean, sturdy work surface.
2. If the drum bearing support (41) was removed from the end plate, install it into the end plate with the vent port near the top and the word "LEVEL" reading correctly in a horizontal plane. Install the bearing support/end plate sub-assembly onto the base using capscrews and washers (60 & 62). Evenly tighten the capscrews to 180 lb.-ft. (244 N-m) torque. Lay the base and end plate over such that the drum bearing support faces up.
3. Install a new bearing into the drum if replacement is necessary, making certain to press it against the shoulder in the bottom of the bearing bore. Coat the outside diameter of a new seal with a good grade of sealant. Turn the spring side of the seal toward the bearing, and press the seal into the seal bore, leaving it flush with the surface of the drum bore.
4. Turn the drum over, and set it down on the bearing support. Be careful not to damage the seal when lowering the drum onto the bearing support.
5. Apply a light coat of oil-soluble grease to the primary sun gear thrust pad (102) then install it into the recess in the primary planet carrier(s).
6. Install the primary planetary carrier assembly (3) into the drum. Rotate the carrier as you mesh the planet gears with the ring gear machined in the drum.
7. Apply a light coat of oil-soluble grease onto the thrust washer (66) and install the thrust washer onto the primary planet carrier. Install the input sun gear (55) into the primary planetary carrier.
8. Install the output planetary carrier assembly (4) into the drum. Rotate the carrier slowly as you mesh the planet gears with the ring gear.
9. Install a new bearing (64) into the drum closure (56) if replacement is necessary, making certain to press it against the shoulder in the bottom of the bearing bore. Lightly coat the outside diameter of a new drum seal (70) with non-hardening sealant. Install the seal into the closure with the garter spring toward the bearing. Press the seal into the bore until it is even with the outside surface of the closure. Install a new o-ring (68) into the groove in the outside diameter of the closure. Lubricate the outside diameter of the closure with multi-purpose grease and install the closure into the drum. Push the closure into the drum until it bottoms against a shoulder machined into the drum. If the closure bottoms on the output planetary carrier before it bottoms in the drum, you may have installed the primary thrust pad upside down and the gear train must be removed to check this condition. Do not proceed until this is resolved.
10. Place the motor side end-plate (40) onto the drum and loosely install the ten capscrews and washers (60 & 62) that secure the end-plate to the base. Do not fully tighten the capscrews at this time.
11. Use multi-purpose grease to lubricate the bearing journal, seal journal and mounting flange surfaces of the brake cylinder housing (2). Carefully install the brake cylinder into the drum closure. It may be necessary to slightly rotate the brake housing to engage the splines of the housing with the output planet carrier.
12. Secure the brake cylinder to the end-plate with eight capscrews and washers (51 & 52). Tighten the capscrews to 80 lb.-ft. (109 N-m) torque. Tighten the fasteners in a cross pattern to maintain even clamp load. Install the over-running brake clutch assembly (1) into the brake cylinder assembly. If the splines of the outer race and the brake discs do not line up, install a hydraulic adapter into the brake release port and connect a hand pump to the adapter. Apply approximately 600 PSI (4150 kPa) to release the static brake. When released, rotate the brake clutch assembly back-and-forth to align the discs. The brake clutch assembly must be installed with the long shoulder of the outer race toward the motor and the internal retaining ring inside the inner race must be offset toward the hoist drum to make room for the motor shaft. The internal retaining ring should seat against the input sun gear when correctly installed. Finish tightening the end plate to base capscrews, installed in step 10 above, to 160 lb.-ft. (217 N-m) torque.

## Sensor Connector

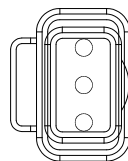

- |       |                            |
|-------|----------------------------|
| 3     | Pin 3 = Ground (Blue)      |
| 2 (-) | Pin 2 = Output (Black) (-) |
| 1 (+) | Pin 1 = Supply (Brown) (+) |

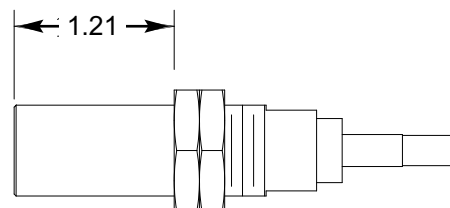

Adjust sensor nut to 1.21 in. (30.7 mm) before installation into motor end plate

13. Turn the two jam nuts on the rotation sensor (144) to produce an installed length of the threads of 1.21 in. (30.7 mm) measured from the bottom of the sensor to the washer against the jam-nut. Apply a small amount of general purpose grease to the threads and install the sensor assembly into the motor end-plate. Tighten until just snug to avoid damage to the sensor.
14. Install a new o-ring (98) onto the motor pilot and install the motor onto the motor adapter/brake cylinder assembly with capscrews and washers (90 & 91). Evenly tighten the capscrews (90) to 282 lb.-ft. (382 N-m) torque.
15. Install the hydraulic lines, removed during disassem-

bly, from the brake valve and motor lowering port manifold to the brake release port on the brake cylinder.

16. After the hoist assembly is complete, check all fasteners and hydraulic fittings to make certain they have been properly tightened. Refill the hoist with the recommended planetary hoist gear oil.
17. Before returning the hoist to full service, a light load should be lifted and held a few feet off the ground to be sure the static brake is functioning properly. The hoist should also be able to slowly lower the load in a smooth and controlled manner. If the hoist does not perform either of these functions correctly, refer to the Trouble Shooting section of this manual.

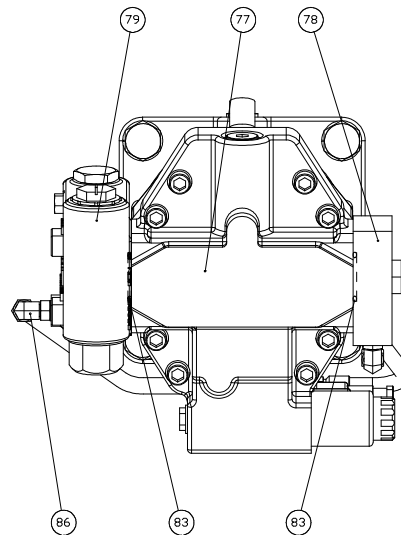
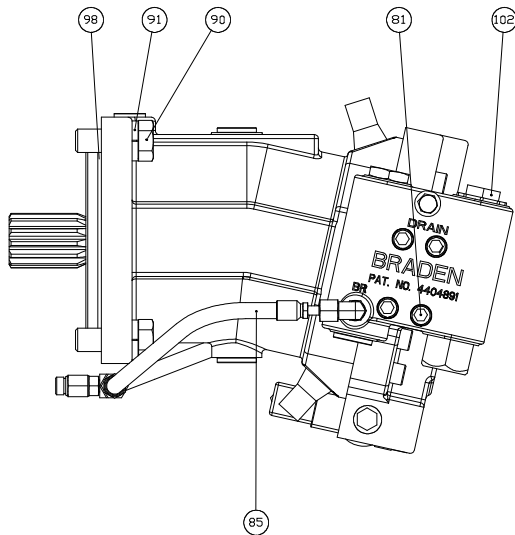

## Motor Group

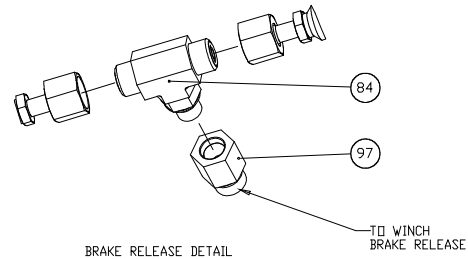
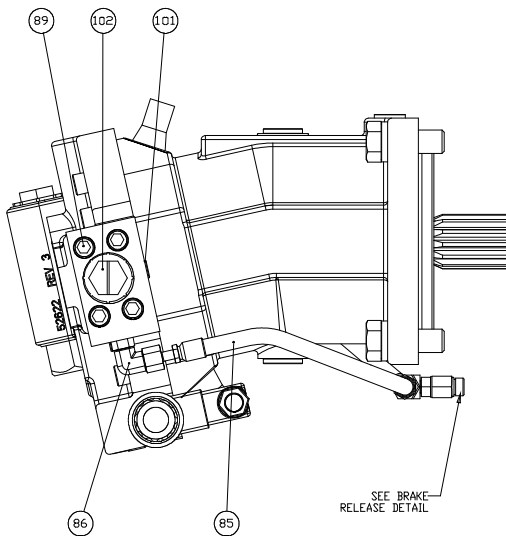

Item	Description	Quantity
77	Hydraulic Motor	1
78	Lowering Port Manifold	1
79	Braden Brake Valve	1
81	Socket Head Capscrew (7/16 - 14 x 3 Gd 8)	4
83	O-ring	2
84	T-ORFS, Brake Release Port	1
85	Hose, Brake Release	2
86	Elbow	2
89	Socket Head Capscrew (7/16 - 14 x 1 1/2 Gd 8)	4
90	Hex Head Capscrew (3/4 - 10 x 2 Gd 8 Z)	4
91	Lockwasher (3/4)	4
97	Adapter, Brake Release Port	1
98	O-ring, Motor Pilot	1
101	Plug, -4 ORB	1
102	Shipping Plug	2

# BRAKE VALVE SERVICE

The BRADEN brake valve is a reliable hydraulic valve with internal components manufactured to close tolerances. Due to the close tolerances and mating of components, the valve housing, spool, piston and check poppet are not available as replacement parts.

Before disassembling the brake valve, be sure you have conducted all applicable troubleshooting operations and are certain the brake valve is causing the malfunction.

Thoroughly clean the outside surfaces of the valve and work in a clean dust free area, as cleanliness is of utmost importance when servicing hydraulic components.

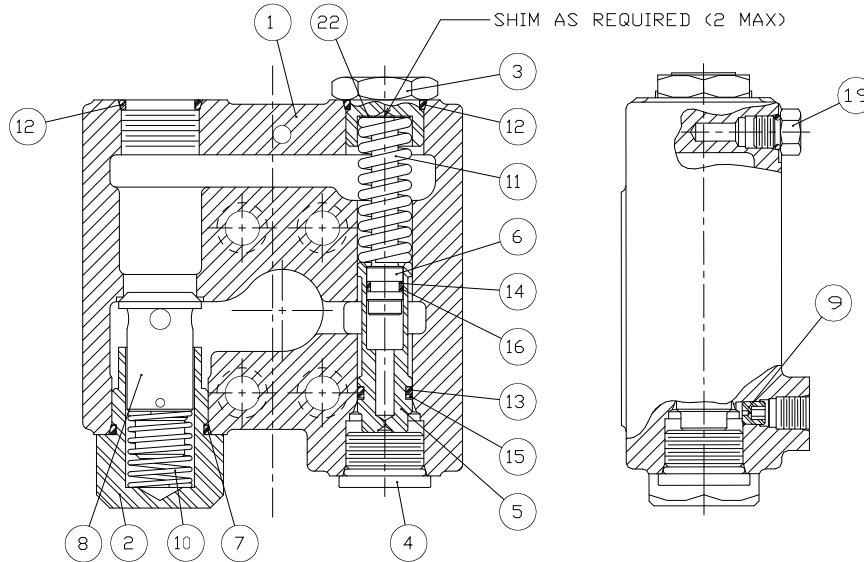

**Brake Valve Assembly**

Item	Description	Quantity
1	Valve Housing (NSS)	1
2	Relief Valve Retainer (NSS)	1
3	Spring Retainer (NSS)	1
4	Plug (NSS)	1
5	Spool (NSS)	1
6	Damper Piston (NSS)	1
7	O-ring	1
8	Relief Valve	1
9	Pilot Orifice	1
10	Relief Valve Spring	1
11	Spool Spring	1
12	O-Ring	2
13	O-Ring	1
14	O-Ring	1
15	Back-up Ring	1
16	Back-up Ring	1
19	Plug -4 ORB	1
22	Shim	A.R.

1. Remove the pilot orifice from the brake release (BR) port using a 5/32 in. Allen wrench.
2. Remove the spool spring retainer (3) and spool spring (11). Check spring free length. Replace spring if less than 1 15/16 in. (49.2 mm) long.

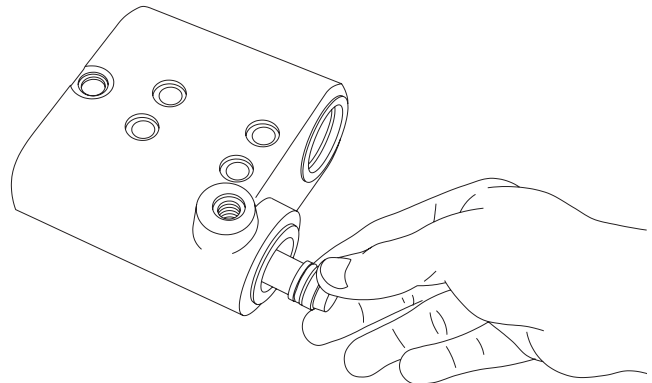

## DISASSEMBLY

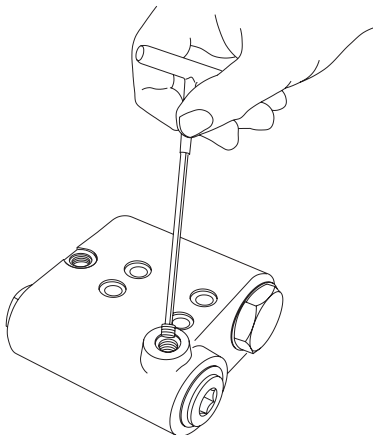

3. Remove spool plug (4) and carefully remove spool assembly (5 & 6).
4. Remove the damper piston (6) from the spool (5). The piston will come out slowly, because of a partial vacuum formed as it is removed. Use extreme care to avoid damaging the polished surfaces of the piston or spool.

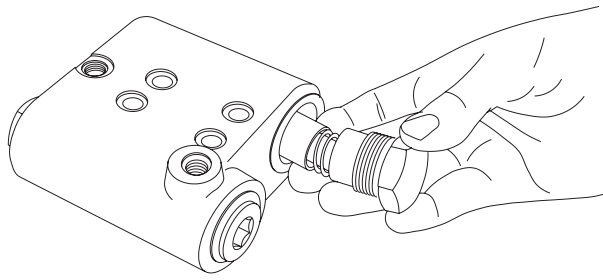

- Remove the inlet relief valve spring retainer (2), spring (10) and relief valve (8). Check spring free length. Replace spring if less than 1 9/16 in. (39.7 mm).

### CLEAN AND INSPECT

- Discard all o-rings and back-up rings. Clean all parts in solvent and blow dry. Inspect polished surfaces of spool and damper piston for damage that may cause binding or leakage. Inspect spool bore in valve housing for damage or scoring. Inspect inlet relief valve seat in valve housing and relief valve poppet. If the spools, bores or valves are damaged, the entire valve must be replaced as these parts are not serviced separately.

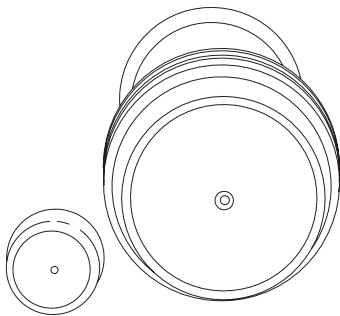

- Inspect the .020 inch (.5 mm) orifice in the end of the spool and the pilot orifice to be certain they are open.

### ASSEMBLY

- Install new o-rings on the plug (4) and spring retainers (2,3).

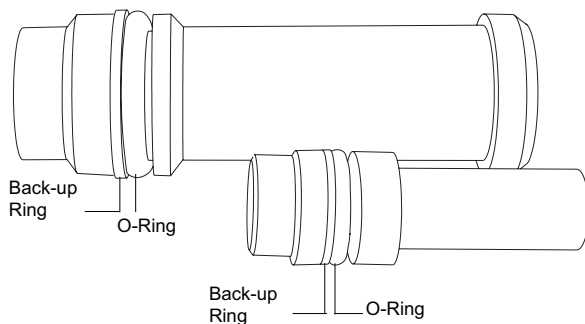

- Install new o-rings and back-up rings on the spool and damper piston as shown. It is important that each back-up ring is on the correct side of its o-ring. Take care not to cut the o-rings during assembly. Let the spool and damper piston set for ten minutes before installing them in their respective bores. This will allow the o-rings to return to their original size after being stretched.
- Lubricate the spool and damper piston o-rings with hydraulic oil. Carefully install the damper piston into the spool.

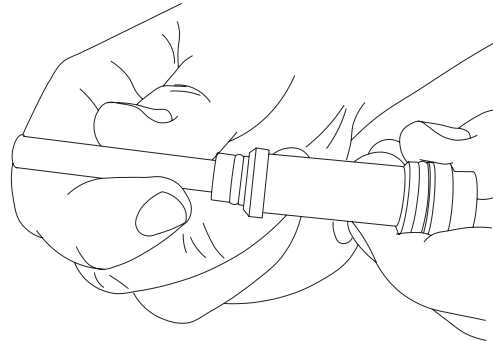

- Lubricate the spool bore and spool o-rings with hydraulic oil. Carefully install the spool into the valve housing. Always install the spool from the plug end to minimize the possibility of damaging the o-ring. Install the plug, spool spring, shim(s), if any, and spring retainer.
- Install the inlet relief valve poppet, spring and relief valve spring retainer.
- Install the pilot orifice into the valve housing.
- The brake valve is now complete and ready to be tested. Install the valve on a hydraulic test stand and set the hydraulic flow to 5 gmp (18.9 lpm). Pumping oil into the split flange motor port, the valve cracking pressure should be 550 psi (3790 kPa) at the release port. Release the control lever and the valve should reseat at 500 psi (3450 kPa). Increase flow to 60 gmp (227 lpm) and the valve cracking pressure should be 1250 psi (8620 kPa). Adjust the cracking pressure by installing shims (22) between the spool spring retainer (3) and the spool spring (11). Now reverse the flow and send 60 gpm (227 lpm) into the threaded inlet port. The inlet pressure drop should be 100 psi (690 kPa) maximum.