

MATERIAL LIST

BRADEN

AMS10
AHS10

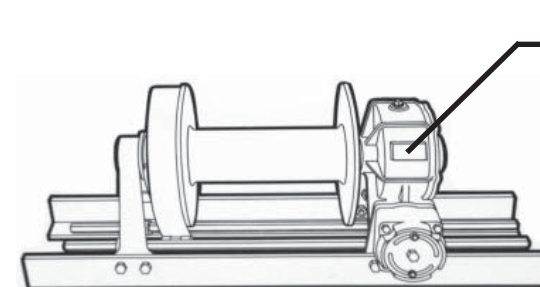
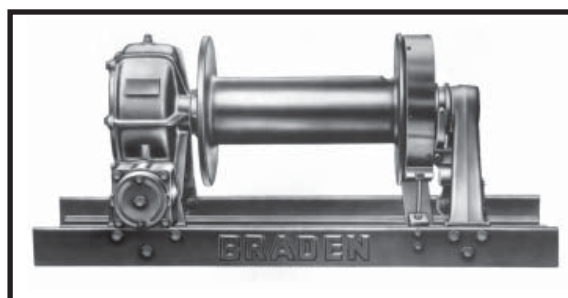

WINCH MODEL NUMBER
WINCH SERIAL NUMBER

Most Braden winches have a raised pad on the housing which is embossed with the model and serial numbers of the winch. Since both of these numbers are extremely important in the shipment of the proper replacement parts, your order should always reference these numbers.

FOR BEST RESULTS, USE ONLY FACTORY CERTIFIED REPLACEMENT PARTS

TO ORDER:

- 1) List model and serial numbers of the winch.
- 2) Refer to illustrations and select the component(s) needed and note item number.
- 3) Find item number on material list, show part number, description, and quantity on your order.
- 4) Refer to parts price list and show price for each component or assembly.

SPECIFICATIONS

Recommended Worm Gear Oil:

We have published the following specifications to help you determine which lubricant is best suited to your application. For simplicity, Braden has listed readily available products in each temperature range which has been tested and found to meet our specifications. This is not to say that other lubricant brands would not perform equally as well.

If the following lubricant brands are not available in your area, make certain your lubricant vendor supplies you with oil that is equivalent to those products listed below.

PREVAILING AMBIENT TEMPERATURE

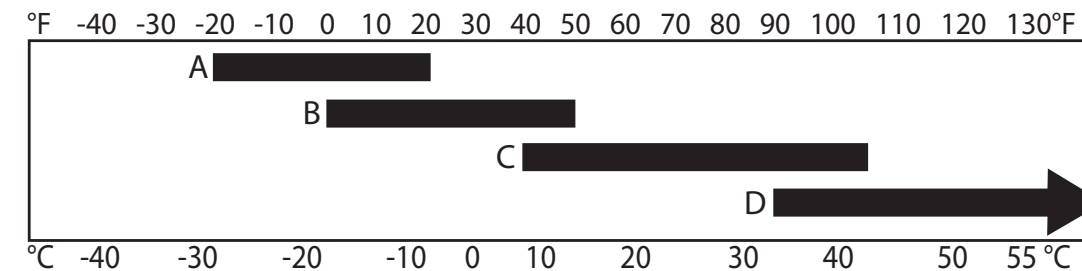

- A. AGMA Grade 3 EP; Mobilgear 600xp 100 or equivalent
- B. AGMA Grade 5 EP; Mobilgear 600xp 220 or equivalent
- C. AGMA Grade 7 EP; Mobilgear 600xp 460 or equivalent
- D. AGMA Grade 8 EP; Mobilgear 600xp 680 or equivalent

Brand recommendations in tier C climate range:

- MOBIL Mobilgear 600xp 460
- SHELL Omala 460
- CHEVRON Gear Compounds EP460
- TEXACO Meropa 460

⚠ WARNING ⚠

Do not use aftermarket additives in worm gear oil. Some additives may contain substances which could cause glazing of brake discs or impede the firm locking action in the brake rotor assembly. Both symptoms could reduce load control which may result in property damage, severe personal injury or death.

BRADEN

AMS10-18, AMS10-18A, AMS10-18B, AH SERIES WITH CLOSE COUPLED HYDRAULIC MOTORS AMS10-18AEB, AMS10-18BEB, AMS10-23AEB - COMPONENTS

(PARTS INTERCHANGEABLE WITH WINCH MODELS MS10-18, MS10-18A, MS10-18B)

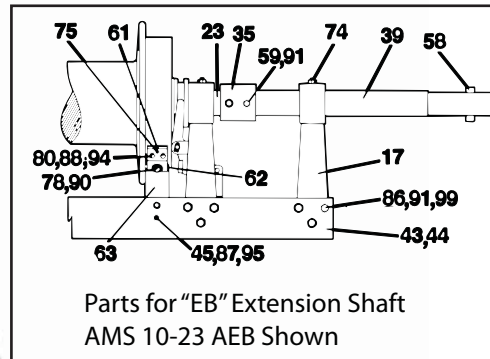
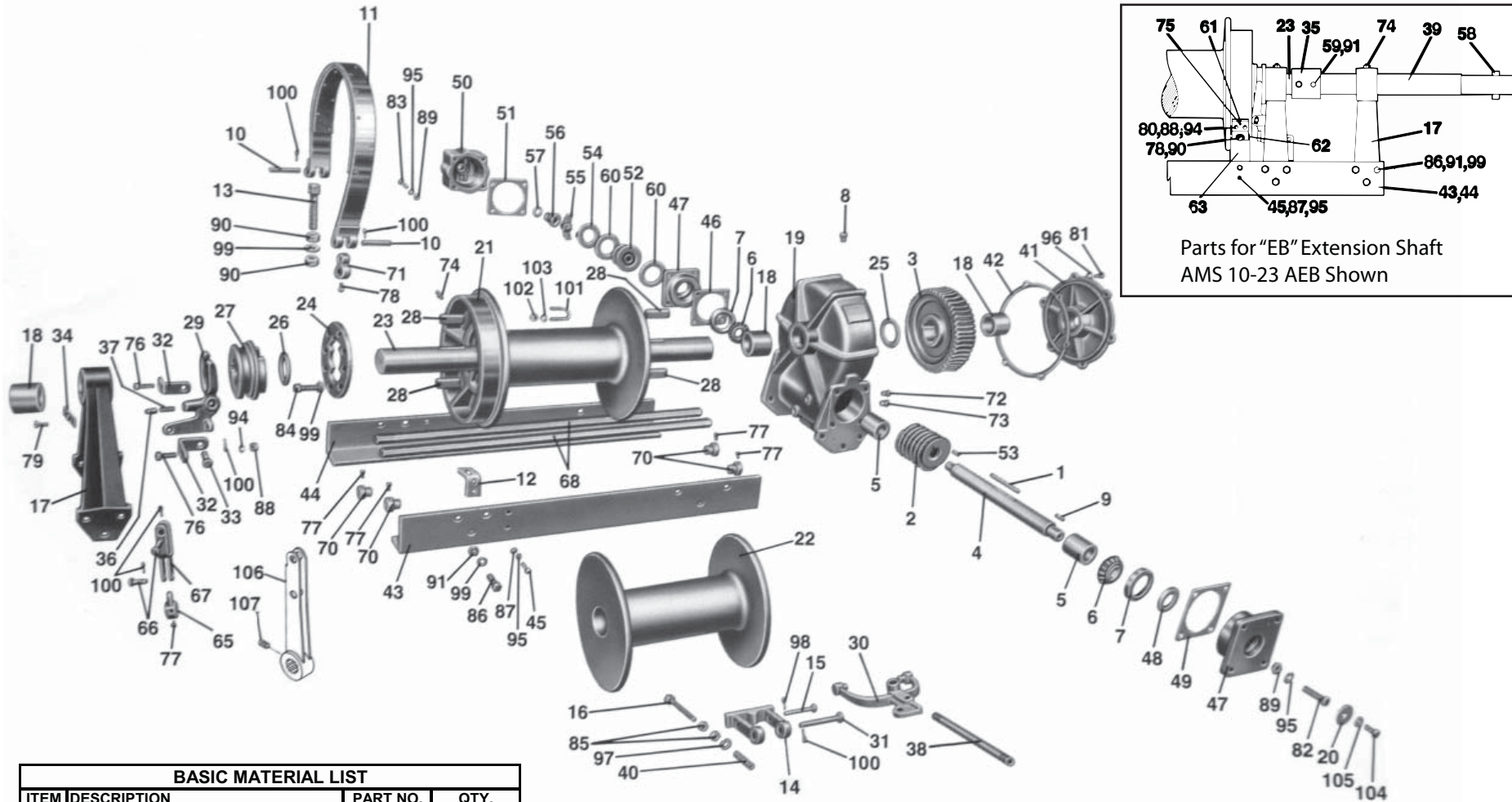

Seal Kit for AMS10 Part Number 62837		
Description	Part No.	Qty.
Gasket (1/64)	11593	2
Gasket (1/32)	11594	6
Cover Gasket	11595	1
Gasket	11706	2
Grease Seal	11005	1
O-Ring	12465	1
Adjusting Nut Gasket	11601	1
Adjusting Nut Washer	11600	1

Seal Kit for AHS10 Part Number 62833		
Description	Part No.	Qty.
Gasket (1/64)	11593	2
Gasket (1/32)	11594	6
Cover Gasket	11595	1
Gasket	11706	2
O-Ring	12465	1
O-Ring	26722	1
Quad Ring	26256	1
O-Ring	72718	1

MATERIAL LIST VARIABLES

ITEM	DESCRIPTION	AMS 10-18 PART NO.	AMS 10-18A PART NO.	AMS 10-18B PART NO.	AMS 10-18AEB PART NO.	AMS 10-18BEB PART NO.	AMS 10-23AEB PART NO.	QTY.
10	Pin, Brake Band	---	---	11051	---	11051	---	2
11	Brake Band Assv.	---	---	81589	---	81589	---	1
12	Anchor Bracket	---	---	11299	---	11299	---	1
13	Brake Band Adj. Link	---	---	11630	---	11630	---	1
14	Brake Shoe Assv. (Incl. Brk. Lng. & Rivet)	88010	88010	---	88010	---	---	1
15	Pin, Clevis (Brake Shoe Link)	18017	18017	---	18017	---	---	1
16	Brake Shoe Link	11587	---	---	11587	---	---	1
17	Bearing, Leg Assv. (Includes Item 18)	81129	81129	81129	---	---	---	1
18	Bearing, Leg Assv. (Includes Item 18)	---	---	---	81129	81129	81129	2
18	Bushing	11031	11031	11031	---	---	---	3
18	Bushing	---	---	---	11031	11031	11031	4
21	Cable Drum	---	---	11300	---	11300	81571	1
22	Cable Drum	11304	11304	---	11304	---	---	1
23	Cable Drum Shaft	23933	23933	23933	22731	22731	23938	1
23	Cable Drum Shaft w/Dual Capstan Lands	22730	22730	22730	---	---	---	1
29	Key	10163	10163	10163	---	---	---	2
29	Shifter Fork	---	11474	11474	11474	11474	11474	1
30	Shifter Fork	11686	---	---	---	---	---	1
31	Pivot Pin	18021	18021	---	18021	---	18021	1
33	Shifter Fork Pin	---	---	11400	---	11400	11400	1
35	Coupling	---	---	---	22901	22901	11740	1
38	Shifter Handle	11591	---	---	---	---	---	1
39	Extension Shaft	---	---	---	11742	11742	23939	1
40	Brake Spring	18002	18002	---	18002	---	18002	1
43	Base Angle FT.	22750	22750	22750	22748	22748	23936	1
44	Base Angle RR.	22751	22751	22751	22749	22749	23937	1
45	Capcrew (7/16 - 14 x 1-3/4 G8 Z)	---	---	104318	---	104318	104318	2
58	Capstan Pin	---	---	---	11980	11980	11980	1
59	Capcrew (5/8 - 18 x 4-1/2 G8 Z)	---	---	---	22512	22512	22512	2
61	Drq. Brk. Shoe Assv. (Incl. Brk. Lng. & Rvt.)	---	---	---	---	---	88005	1
62	Drag Brake Sleeve	---	---	---	---	---	12782	1
63	Drag Brake Bracket	---	---	---	---	---	11736	1
65	Clutch Lever	---	11981	11981	11981	11981	11981	1
66	Clevis Pin	---	11480	11480	11480	11480	11480	2
67	Double Clevis	---	11481	11481	11481	11481	11481	1
68	Control Shaft	---	11482	---	11482	---	11482	1
68	Control Shaft	---	---	11482	---	11482	---	2
70	Bearing Collar	---	11669	---	11669	---	11669	2
70	Bearing Collar	---	---	11669	---	11669	---	4
71	Brake Band Lever	---	---	11066	---	11066	---	1
74	Grease Fitting	18047	18047	---	---	---	---	3
74	Grease Fitting	---	---	---	18047	18047	18047	4
75	Rollpin	---	---	---	---	---	12026	1
77	Set Screw	---	13957	---	13957	---	13957	3
77	Set Screw	---	---	13957	---	13957	---	6
78	Jam Nut (3/4 - 10)	---	---	---	---	---	11791	2
80	Capcrew (3/8 - 16 x 2-3/4 G8 Z)	---	---	---	---	---	104139	2
85	Jam Nut (1/4 - 28)	13468	13468	---	13468	---	---	2
86	Capcrew (5/8 - 18 x 2 G8 Z)	22699	22699	22699	---	---	---	12
86	Capcrew (5/8 - 18 x 2 G8 Z)	---	---	---	22699	22699	22699	18
87	Nut (7/16 - 14)	---	---	13566	---	13566	13566	2
88	Nut (3/8 - 16)	11780	11780	11780	11780	11780	---	4
88	Nut (3/8 - 16)	---	---	---	---	---	11780	8
90	Adjusting Screw	---	---	---	---	---	11398	1
91	Nut (5/8 - 18)	22702	22702	---	---	---	---	12
91	Nut (5/8 - 18)	---	---	22702	---	---	---	14
91	Nut (5/8 - 18)	---	---	---	22702	---	22702	20
91	Nut (5/8 - 18)	---	---	---	---	22702	---	22
94	Lockwasher (3/8)	27152	27152	27152	27152	27152	---	4
94	Lockwasher (3/8)	---	---	---	---	---	27152	8
95	Lockwasher (7/16)	11025	11025	---	11025	---	---	8
95	Lockwasher (7/16)	---	---	11025	---	11025	11025	10
97	Washer	11072	11072	---	11072	---	---	1
98	Cotter Pin	11078	11078	---	11078	---	---	1
99	Lockwasher (5/8)	102423	102423	---	---	---	---	20
99	Lockwasher (5/8)	---	---	102423	---	---	---	21
99	Lockwasher (5/8)	---	---	---	102423	---	102423	28
99	Lockwasher (5/8)	---	---	---	---	102423	---	29
100	Cotter Pin	18008	---	---	---	---	---	1
100	Cotter Pin	---	18008	---	18008	---	18008	3
100	Cotter Pin	---	---	18008	---	18008	---	7
106	Shaft Lever	---	13249	---	13249	---	13249	1
106	Shaft Lever	---	---	13249	---	13249	---	2
107	Cotter Pin	---	13959	---	13959	---	13959	1
107	Cotter Pin	---	---	13959	---	13959	---	2

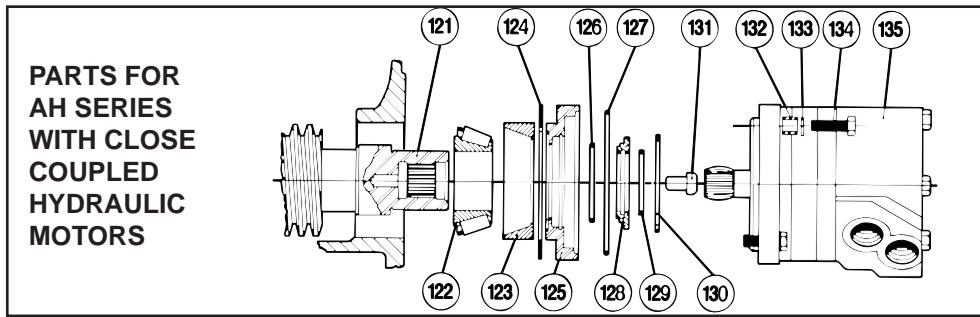

BASIC MATERIAL LIST

ITEM	DESCRIPTION	PART NO.	QTY.
1	Key	11484	1
2	Worm, Right Hand	11064	1
2	Worm, Left Hand	11063	1
3	Worm Gear, Right Hand	11297	1
3	Worm Gear, Left Hand	11296	1
4*	Worm Shaft	11485	1
5*	Spacer	11712	2
6*	Bearing Cone	18006	2
7*	Bearing Cup	18043	2
8	Plug	22775	1
9*	Key	23367	1
19	Worm Housing (Includes Item 18)	81052	1
20*	Sprocket Washer	18045	1
24	Clutch Plate	11209	1
25	Thrust Ring	11291	1
26	Retaining Ring	11046	1
27	Clutch	11293	1
28	Key	22755	4
32	Bracket	11607	2
34	Shifter Lock	11612	1
36	Poppet	11608	1
37	Spring	11592	1
41	Worm Hsq. Cover (Includes Item 18)	81053	1
42	Gasket	11706	1
46	Gasket (1/64)	11593	2-AR
47*	Bearing Container	22756	2
48*	Hsq Grease Seal	11005	1
49	Gasket (1/32)	11594	4-AR
50	Worm Brake Housing	11613	1
51	Cover Gasket	11595	1
52	Rotor Assy.	81114	1
53	Key	18044	1
54	Pressure Plate	11610	1
55	Brake Spring Assv. (Includes Items 56)	88006	1
56	Adjusting Nut	11599	1
57	O'Ring	12465	1
60	Brake Disc	11979	2
72	Pipe Plug	18009	1

BASIC MATERIAL LIST

ITEM	DESCRIPTION	PART NO.	QTY.
73	Pipe Plug	18010	1
76	Capcrew (3/8 - 16 x 1-1/4 G8 Z)	104132	2
79	Capcrew (3/8 - 16 x 1-1/2 G8 Z)	104313	2
81	Capcrew (7/16 - 14 x 1 G8 Z)	21964	6
82*	Capcrew (7/16 - 20 x 2 NF G8 Z)	23585	4
83	Capcrew (7/16 - 20 x 4-1/2 NF G8 Z)	23586	4
84	Capcrew (5/8 - 11 x 1-3/4 G8 Z)	103249	8
89*	Nut (7/16 - 20)	12794	8
96	Washer, Shprf	11014	6
101	Cable Clamp	11704	1
102	Nut (1/2)	101439	2
103	Lockwasher (1/2)	11026	2
104*	Capcrew (5/16 - 24 x 3/4 NF G8 Z)	32265	1
105*	Lockwasher (5/16)	11024	1

AH SERIES PARTS

ITEM	DESCRIPTION	PART NO.	QTY.
121	Worm Shaft	26633	1
122	Bearing Cone	26258	1
123	Bearing Cup	26257	1
124	Gasket	11593	1
125	Bearing Retainer	26012	1
126	O'Ring	26722	1
127	O'Ring	72718	1
128	Seal Container	26255	1
129	Quad Ring	26256	1
130	Snap Ring	25700	1
131	Rest Button	26263	1
133	Lockwasher (1/2)	11026	4
134	Capcrew (1/2 - 13 x 1-1/4 G8 Z)	104174	4
135	Hydraulic Motor (Single Speed)	26310	1
135	Hydraulic Motor (Two Speed)	101166	1

* These items do not apply to AH Series