

# CH165A, CH175B, CH230B Planetary Hoist

## INSTALLATION, MAINTENANCE, AND SERVICE MANUAL

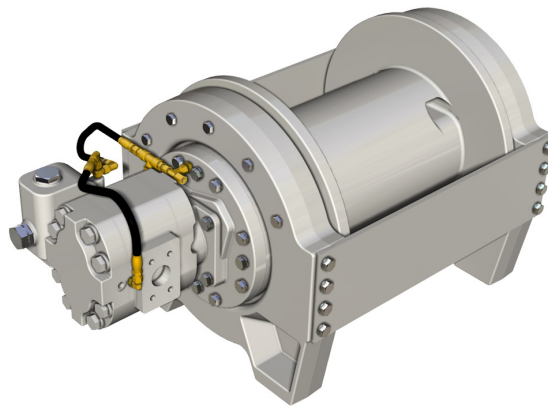

**WRITE HOIST SERIAL NUMBER BELOW**

--	--	--	--	--	--	--



**First 2 numbers indicate  
year manufactured**

For serial number location, see Page 3

Visit our Web site at [www.paccarwinch.com](http://www.paccarwinch.com) for the most comprehensive collection of winch, hoist, and drive information on the Internet. Most publications and specification sheets are available for downloading.

## Table of Contents

Foreword .....	3
Model Identification .....	3
Explanation of Model Number.....	3
Glossary .....	4
General Safety Recommendations .....	5
Basic Operation.....	7
Installation .....	9
Wire Rope Installation .....	10
Hoist Operation .....	11
Hydraulic Circuit .....	12
Recommended Fastener Torque .....	12
Preventive Maintenance.....	13
Recommended Gear Oil.....	14
Oil Sampling and Analysis .....	15
Troubleshooting.....	16
Disassembly Procedure .....	20
Major Components Cross-section .....	22
Planet Carrier Service .....	23
Overrunning Clutch Service .....	25
Brake Cylinder Service.....	26
Reversing Direction of Drum Rotation.....	30
Hoist Assembly.....	32
Brake Valve Service .....	34
Brake Valve Opening Pressure Test.....	36
Metric Conversion Table .....	39

---

## FOREWORD

---

The following service instructions have been prepared to provide assembly, disassembly, and maintenance information for the BRADEN Model CH165A, CH175B, and CH230B series hoist. It is suggested that before doing any work on these units, all assembly and disassembly instructions should be read and understood.

Some illustrations in this manual may show details or attachments that are different from your hoist. Also, some components have been removed for illustrative purposes.

Continuing product improvement may cause changes in your hoist, which are not included in this manual. For inquiries regarding your BRADEN planetary hoist or this publication, please contact the PACCAR Winch Service Department at 918-251-8511, Monday through Friday, 8:00 a.m. to 4:30 p.m. (CST), [www.paccarwinch.com](http://www.paccarwinch.com).

---

## MODEL IDENTIFICATION

---

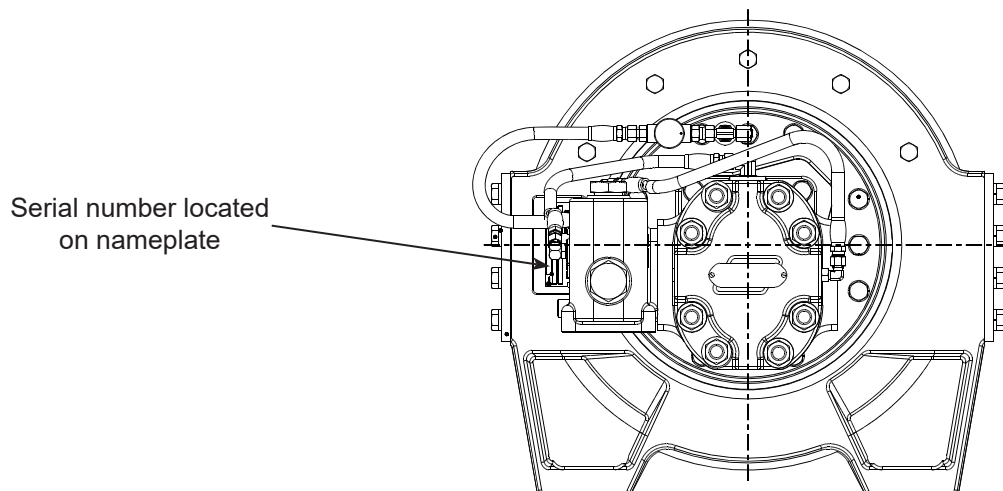

---

## EXPLANATION OF MODEL NUMBER

---

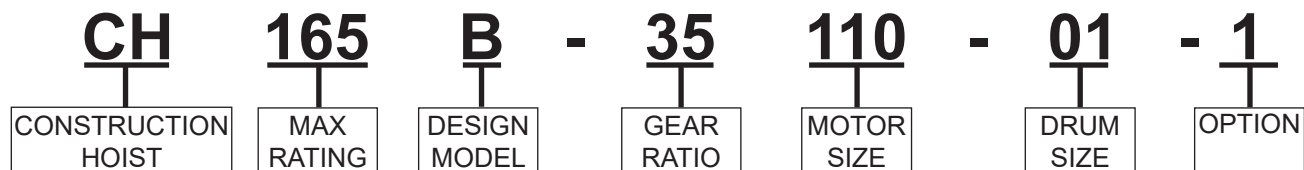

**CH** Construction hoist

**165** 16,500-lbs. first-layer line pull (CH165); 17,500 lbs. (CH175); 23,000 lbs. (CH230)

**B** Model series relating to design changes

**35** Total gear reduction (CH165 = 25, 26; CH175 = 22; CH230 = 35, 36)

**110** Hydraulic motor displacement in cubic inches/revolution (110 = 11.0 cu. in./rev)

**01** Drum option

**1** Permits testing and inspection per API 2C for offshore cranes –

## GLOSSARY

**Brake Valve** — A hydraulic counterbalance valve should be connected to the reel-in port of the hydraulic motor. It allows oil to flow freely through the motor in the winching direction. When oil pressure tries to rotate the motor in the reel-out direction, the brake valve blocks the flow of oil out of the motor until the internal static brake is released. It then controls reel-out speed based on the load and flow of oil to the motor. All the heat generated by controlling the speed of the load is dissipated by the hydraulic system, not by the internal static brake.

**Grooved Drum** — A cable drum with grooves on the barrel to ensure the first layer of cable spools properly onto the drum. The grooves can be cast or machined into the drum, or cast or machined into separate pieces that are mechanically fastened to the drum.

**NOTE:** Only one size cable can be used on a grooved drum.

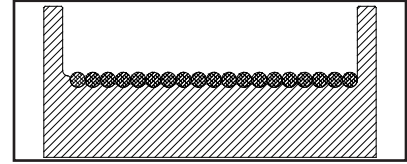

**Sprag or Overrunning Clutch** — A mechanical one-way clutch on the input shaft of the winch, between the input shaft and the static mechanical brake. The clutch allows the input shaft to turn freely in the direction required to spool cable onto the drum, then immediately locks the winch gear train to the mechanical brake when the winch is stopped, holding the load in place.

**Static, Mechanical, or Load-holding Brake** — A multidisc, spring-applied, hydraulically released brake that works together with the sprag clutch to hold a load. This brake is not designed to stop a load being lowered, but holds the load in place when the winch is not in operation.

**First-layer Line-pull Rating** — The maximum rated line pull (in pounds or kilograms) on the first layer of cable. The maximum rating for any particular winch is based on maintaining an acceptable structural design factor and service life. Certain combinations of drum, gear ratio, motor and hydraulic pressure, may reduce this rating.

**First-layer Line-speed Rating** — The maximum rated line speed (in feet or meters per minute) on the first layer of cable. Certain combinations of drum, gear ratio, motor, and hydraulic flow may reduce or increase this rating.

**D/d Ratio** — The ratio of cable drum barrel diameter (D) to wire/synthetic rope diameter (d). Current ANSI standards require a minimum of 17:1. Current SAE standards require a minimum of 8:1.

### EXAMPLES:

If you know the cable diameter you want to use, multiply it by 17 to get the **MINIMUM** cable drum barrel diameter. (For example, 1/2-inch wire rope X 17 = 8.5 inches — this is the minimum hoist barrel diameter)

If you know the barrel diameter, divide it by 17 to get the **MAXIMUM** wire rope diameter.

(For example, 10-inch barrel diameter / 17 = 0.588, or 9/16 inch — this is the maximum wire rope diameter)

### Cable Drum Dimensions —

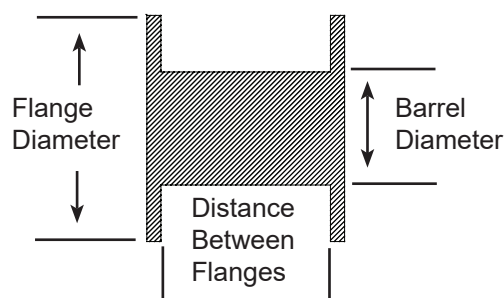

**Fleet Angle** — The angle between the wire/synthetic rope position at the extreme end wrap on a drum, and a line drawn perpendicular to the axis of the drum, through the center of the nearest fixed sheave or load attachment point.

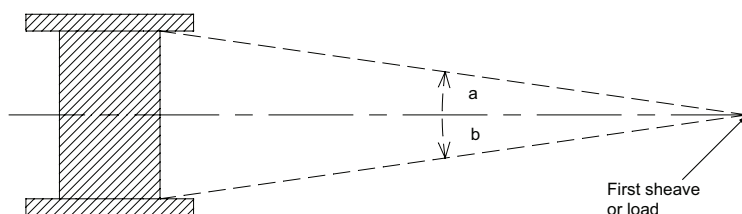

First sheave or load should be centered between the drum flanges, so that angles A and B are equal.

Angles A and B should be a minimum of 1/2 degree and a maximum of 1-1/2 degrees.

**Wrap** — A single coil of wire/synthetic rope wound on a drum.

**Layer** — All wraps of wire/synthetic rope on the same level between drum flanges.

**Freeboard** — Amount of drum flange that is exposed radially past the last layer of wire/synthetic rope. Minimum freeboard varies with the regulatory organization. ASME B30.5 requires 1/2-inch minimum freeboard. SAE J706 requires minimum freeboard of 0.7d, where d is rope diameter.

---

## GENERAL SAFETY RECOMMENDATIONS

---

Safety for operators and ground personnel is of prime concern. Always take the necessary precautions to ensure safety to others as well as yourself. To ensure safety, the prime mover and hoist must be operated with care and concern for the equipment and a thorough knowledge of the machine's performance capabilities. The following recommendations are offered as a general safety guide. Local rules and regulations will also apply.

1. Be certain equipment (boom, sheave blocks, pendants, etc.) is either lowered to the ground or blocked securely before servicing, adjusting, or repairing hoist.
2. Be sure personnel are clear of work area **BEFORE** operating hoist.
3. Read all warning and caution tags provided for safe operation and service of the hoist and become familiar with the operation and function of all controls before operating the hoist.
4. Inspect rigging and hoist at the beginning of each work shift. Defects should be corrected immediately. **DO NOT** operate a hoist with defects.
5. Keep equipment in good operating condition. Perform scheduled servicing and adjustments listed in the Preventive Maintenance section of this manual.
6. An equipment warm-up procedure is recommended for all start-ups and essential at ambient temperatures below +40°F (+4°C). Refer to Warm-up Procedure listed in the Preventive Maintenance section of this manual.
7. **DO NOT** exceed the maximum pressure (PSI, kPa) or flow (GPM, lpm) stated in the hoist specifications found in the specific sales brochure.
8. Operate hoist line speeds to match job conditions.
9. Protective gloves should be used when handling wire rope.
10. **NEVER** attempt to handle wire rope when the hook end is not free. Keep all parts of body and clothing clear of cable rollers, cable entry area of fairleads, sheaves and hoist drum.
11. When winding wire rope on the hoist drum, never attempt to maintain tension by allowing wire rope to slip through hands. Always use hand-over-hand technique.
12. Never use wire rope with broken strands. Replace wire rope that is damaged. Refer to wire rope supplier manual.
13. **DO NOT** weld on any part of the hoist without approval from PACCAR Winch Engineering.
14. Use recommended hydraulic oil and gear lubricant.
15. Keep hydraulic system clean and free from contamination at all times.
16. Use correct anchor for wire rope and pocket in drum.
17. **DO NOT** use knots to secure or attach wire rope.
18. The BRADEN designed wire rope anchors are **NOT** intended to support the rated load. **ALWAYS** maintain a minimum of five wraps of wire rope on the drum. It is recommended that the last five wraps of wire rope be painted bright red to serve as a visual reminder.
19. Never attempt to clean, oil or perform any maintenance on a machine with the engine or prime mover running, unless instructed to do so in this manual.
20. Never operate hoist controls unless you are properly positioned at the operators station and you are sure personnel are clear of the work area.
21. Assure that personnel who are responsible for hand signals are clearly visible and that the signals to be used are thoroughly understood by everyone.
22. Ground personnel should stay in view of the operator and clear of the hoist drum. **DO NOT** allow ground personnel near wire rope under tension. A safe distance of 1-1/2 times the working length of the wire rope should be maintained.
23. Install guarding to prevent personnel from getting any part of body or clothing caught at a point where the cable is wrapped onto the drum or drawn through guide rollers or potential pinch points.
24. Install switches or valves that will shut off power to the hoist, in locations where they can be reached by anyone entangled in the wire rope before being drawn into the hoist or any pinch point.
25. Deadman controls, which automatically shut off power to the hoist whenever the operator leaves his station or releases the hoist control lever, should be installed whenever practical.
26. **NEVER** allow anyone to position any part of body under a suspended load.
27. Avoid sudden shock loads or attempting to jerk a load free. This type of operation may cause heavy loads, in excess of rated capacity, which may result in failure of wire rope, hoist or crane structure.
28. Whenever possible, install the hoist in a location that is not immediately adjacent to a normal operator's station.
29. All hoist controls shall be located within easy reach of the operator. The controls shall be installed in such a location that the operator is removed from the electrical path to ground if the load, rigging, or wire rope come in contact with or within proximity to an electrically energized conductor.

---

## GENERAL SAFETY RECOMMENDATIONS

---

**30.** Before operating the hoist, be sure ALL safety procedures for the equipment or vehicle the hoist is mounted on are properly followed and/or in place.

If there is any question regarding the preceding safety recommendations, or the safe operation of your hoist, please contact the PACCAR Winch Service Department at 918-251-8511, Monday through Friday, 8:00 a.m. to 4:30 p.m. (CST), or [www.paccarwinch.com](http://www.paccarwinch.com) for the latest available information.

**Safety and informational callouts used in this manual include:**

### **WARNING**

**WARNING** – This emblem is used to warn against hazards and unsafe practice which COULD result in severe personal injury or death if proper procedures are not followed.

### **CAUTION**

**CAUTION** – This emblem is used to warn against potential or unsafe practices which COULD result in personal injury and product or property damage if proper procedures are not followed.

# BASIC OPERATION

## DESCRIPTION OF HOIST

The CH165A, CH175B, and CH230B hoists are made up of the following subassemblies:

1. Hydraulic motor and brake valve
2. Brake cylinder and brake clutch assembly
3. Hoist base components
4. Hoist drum and gear train

## THEORY OF OPERATION

The primary sun gear is directly coupled to the hydraulic motor by the inner race of the brake clutch assembly. As the motor turns in the hoisting direction (clockwise for -01 drums) the planetary assemblies reduce the input speed of the motor and rotate the ring gear and winch drum. Since the output planet carrier is held from turning by the drum bearing support on -01 drums, the drum rotates in the opposite direction of the motor input shaft. On -02 and -21 drums the output carrier is splined to the drum, and the drum rotates in the same direction as the input shaft. In the hoisting direction, the static brake remains fully applied and the input shaft rotates freely through the sprag clutch. When the motor is stopped, the load tries to rotate the hoist gear train in the opposite direction. The sprag clutch on the input shaft immediately locks up, allowing the fully applied static brake to hold the load from dropping. See Dual Brake System — Operation for a detailed description of the lowering sequence of operation.

### Dual Brake System — Description

The dual brake system consists of a dynamic brake system and a static brake system.

The dynamic brake system has two operating components:

1. Brake valve assembly
2. Hydraulic motor

The brake valve is basically a counterbalance valve with improved metering. It contains a check valve to allow free flow of oil.

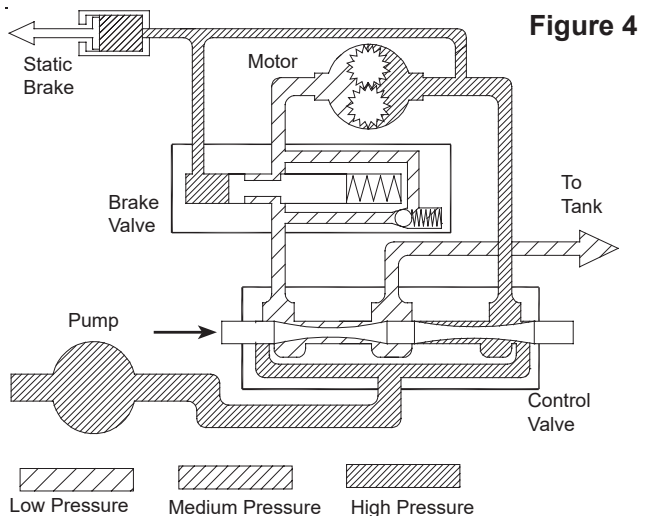
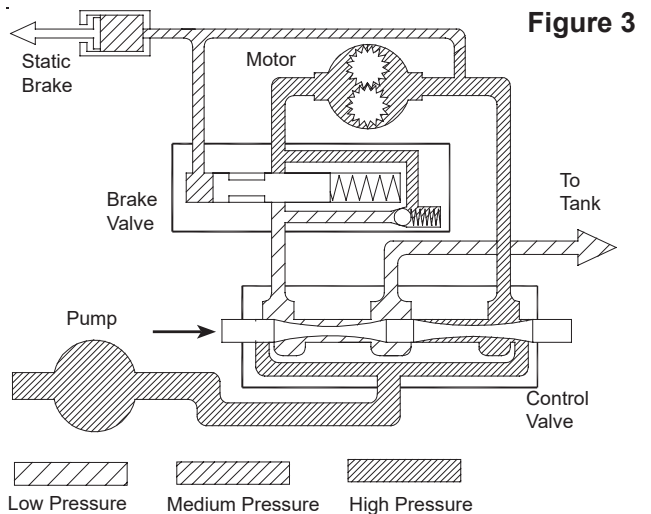
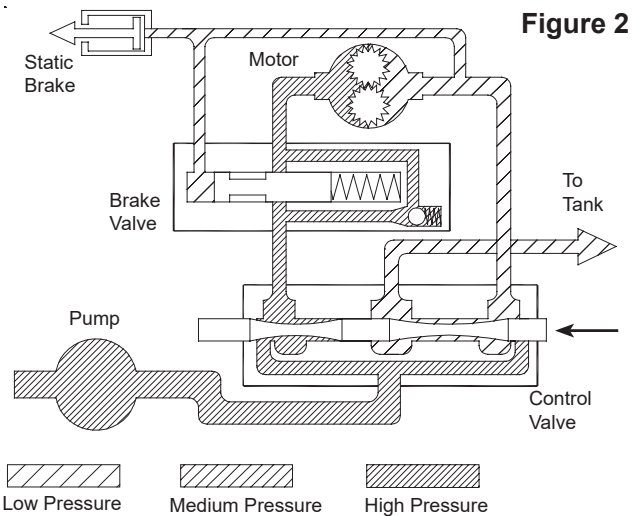



---

## BASIC OPERATION

---

The static brake is released by the brake valve pilot pressure at a pressure lower than that required to open the pilot operated spool valve. This sequence assures that dynamic braking takes place in the brake valve and that little, if any, heat is absorbed by the friction brake.

The static friction brake is a load-holding brake only and has nothing to do with dynamic braking or rate of descent of a load.

The brake clutch is splined to the primary sun gear shaft between the motor and the primary sun gear. It will allow this shaft to turn freely in the direction to raise a load and lock up to force the brake discs to turn with the shaft in the direction to lower a load (Figures 5 and 6).

The hydraulic cylinder, when pressurized, will release the spring pressure on the brake discs, allowing the brake discs to turn freely.

### Dual Brake System — Operation

When hoisting a load, the brake clutch which connects the motor shaft to the primary sun gear, allows free rotation. The sprag cams lay over and permit the inner race to turn free of the outer race (Figure 5). The static friction brake remains fully engaged. The hoist, in raising a load, is not affected by any braking action (Figure 2).

When the lifting operation is stopped, the load attempts to turn the primary sun gear in the opposite direction. This reversed input causes the sprag cams to instantly roll upward and firmly lock the shaft to the fully engaged friction brake (Figure 6).

When the hoist is powered in reverse, to lower the load, the motor cannot rotate until sufficient pilot pressure is present to open the brake valve (Figures 3 and 4). The friction brake within the hoist will completely release at a pressure lower than that required to open the brake valve. The extent to which the brake valve opens will determine the amount of oil that can flow through it and the speed at which the load will be lowered. Increasing the flow of oil to the hoist motor will cause the pressure to rise and the opening in the brake valve to enlarge, speeding up the descent of the load. Decreasing this flow causes the pressure to lower and the opening in the brake valve to decrease thus slowing the descent of the load.

When the control valve is shifted to neutral, the pressure will drop and the brake valve will close, stopping the load. The friction brake will engage and hold the load after the brake valve has closed.

When lowering a load slowly for precise positioning, little oil flow actually occurs through the hoist motor. The pressure will build up to a point where the static brake will release sufficiently to allow the load to rotate the motor through its own internal leakage. This feature results in a slow speed and accurate positioning.

The friction brake receives little wear in the lowering operation. All of the heat generated by the lowering and stopping of a load is absorbed by the hydraulic oil where it can be readily dissipated.

**Figure 5** Static Friction Brake Applied

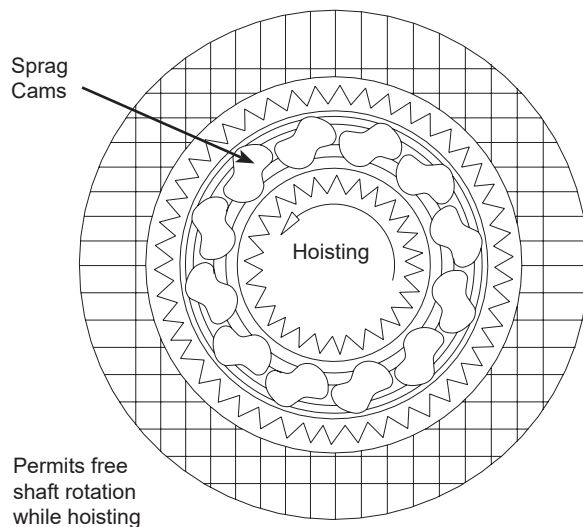

**Figure 6** Static Friction Brake Applied

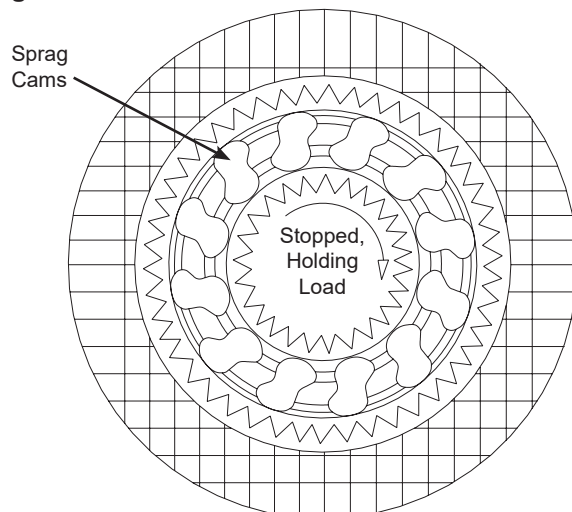

Load attempts to rotate shaft in opposite direction. Brake clutch locks sun gear shaft to friction brake.



## INSTALLATION — GENERAL REQUIREMENTS

1. The hoist must be mounted with the centerline of the drum in a horizontal position. The mounting plane can be rotated to any position around this centerline, providing the vent plug is positioned above the oil level.
2. When mounting the hoist, use four 1-1/4 inch Grade 8 capscrews or bolts and nuts using both mounting holes in each end plate. Use narrow, hardened washers under the bolt heads and nuts

### ⚠ WARNING ⚠

**DO NOT** weld hoist to mounting surface. Welding may not provide adequate structural support for wind loads. This may cause loss of load control, which could result in property damage, injury, or death. Welding may also damage bearings and seals, resulting in premature failure.

3. The vent plug must always be located above the horizontal centerline of the hoist drum. If the hoist is mounted on a pivoting surface, be sure the vent remains above the centerline at all times. If necessary, reposition the bearing support.
4. It is important that the hoist be mounted on a surface that will not flex when the hoist is in use, since this could bind the working parts of the hoist. Also, be sure the hoist is mounted on a flat surface. If necessary, use shim stock to ensure proper mounting. The mounting surface must be flat within 0.020 inches (.5 mm).
5. Hydraulic lines and components that operate the hoist should be of sufficient size to assure minimum back pressure at the hoist motor ports. To ensure adequate static brake load holding ability, back pressure on the hoist should not exceed 100 PSI (690 kPa).
6. Make certain that the hoist drum is centered behind the first sheave and the fleet angle does not exceed 1-1/2 degrees.

The hoist should also be mounted perpendicular to an imaginary line from the center of the drum to the first sheave to ensure even spooling (see drawing on page 4).

### ⚠ WARNING ⚠

**DO NOT** use a control valve with any detents or latching mechanism that would hold the control valve in an actuated or running position when the operator releases the control handle. Use of the wrong type of control valve could lead to unintentional operation of the hoist, which could result in property damage, personal injury, or death.

7. The hoist directional control valve must be a three-position, four-way valve without detents and with a spring centered motor spool such that the valve returns to the centered position whenever the handle is released, and both work ports are opened to tank (open center, open port, see schematic below).
8. The hydraulic oil filter should have a 10-micron nominal rating and be a full-flow type.
9. High-quality hydraulic oil is essential for satisfactory performance and long hydraulic system component life.

Oil having 150 to 330 SUS viscosity at 100°F (38°C) and viscosity index of 100 or greater will give good results under normal temperature conditions. The use of an oil having a high viscosity index will minimize cold-start trouble and reduce the length of warm-up periods. A high viscosity index will minimize changes in viscosity with corresponding changes in temperature.

Maximum cold weather start-up viscosity should not exceed 5000 SUS with a pour point at least 20°F (11°C) lower than the minimum temperature.

In general terms; for continuous operation at ambient temperatures between 50 and 110°F (10-43°C) use ISO VG 46 – 68 (SAE 20); for continuous operation between 10 and 90°F (-12 and 32°C) use ISO VG 32 (SAE 10W).

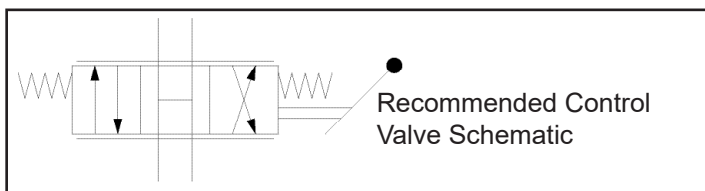

# WIRE ROPE INSTALLATION — ONE-PIECE CABLE WEDGE

## ⚠ WARNING ⚠

### THE CABLE ANCHORS ALONE ON HOISTS ARE NOT INTENDED TO HOLD RATED LOADS.

Hoist loads applied directly to the wire rope anchor may cause the wire rope to pull free and result in the sudden loss of load control and cause property damage, personal injury, or death. A minimum of 5 wraps of wire rope must be left on the drum barrel to achieve rated load.

The wedge and anchor pocket must be clean and dry. The end of the wire rope being anchored to the drum must be clean, dry, and not frayed. Anything on the end of the wire rope to keep it from fraying (such as tape or wire) must not be in contact with the wedge when the installation is complete. Consult the wire rope manufacturer on the proper treatment of the dead end of the wire rope. Some rope manufacturers recommend when using rotation-resistant wire rope, that the rope end be seized, welded, or brazed before inserting the wire rope into the wedge socket to prevent core slippage or loss of rope lay.

Take the free end of the wire rope and insert it through the small opening on the cable drum. Loop the wire rope and push the free end about 3/4 of the way back through the pocket. Install the wedge as shown in Figure 1, then pull the slack out of the wire rope. The dead end of the rope needs to extend slightly beyond the end of the wedge as shown in Figure 2.

Using a hammer and brass drift, drive the wedge as deep into the pocket as possible to ensure it is fully seated and no further movement is detected. Applying a load on the wire rope will also help seat the wedge in the pocket. Check to ensure the wedge does not protrude from either end of the pocket, causing it to interfere with proper spooling of wire rope onto the drum (Figures 1 and 2).

If there is interference or the wedge does not seat firmly, contact the BRADEN Product Support Department at 1-918-251-8511 to determine the proper wedge size.

It is important that the wire rope have the proper tensioning when it is installed on the drum. When the wire rope is first installed, you should operate the hoist, with light to moderate loads, with reeving that let's you place these loads on the block and the drum with all the rope off the drum except for the last five wraps.

## Correct Installations

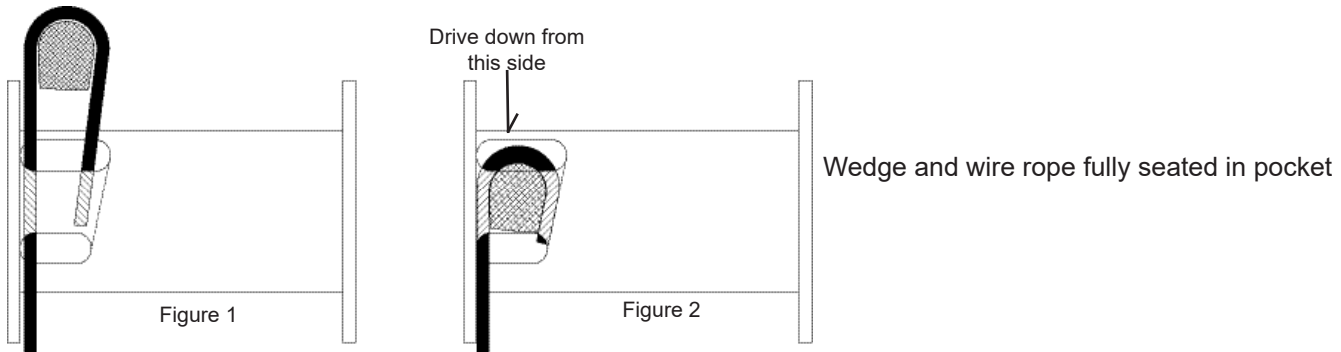

## Incorrect Installations

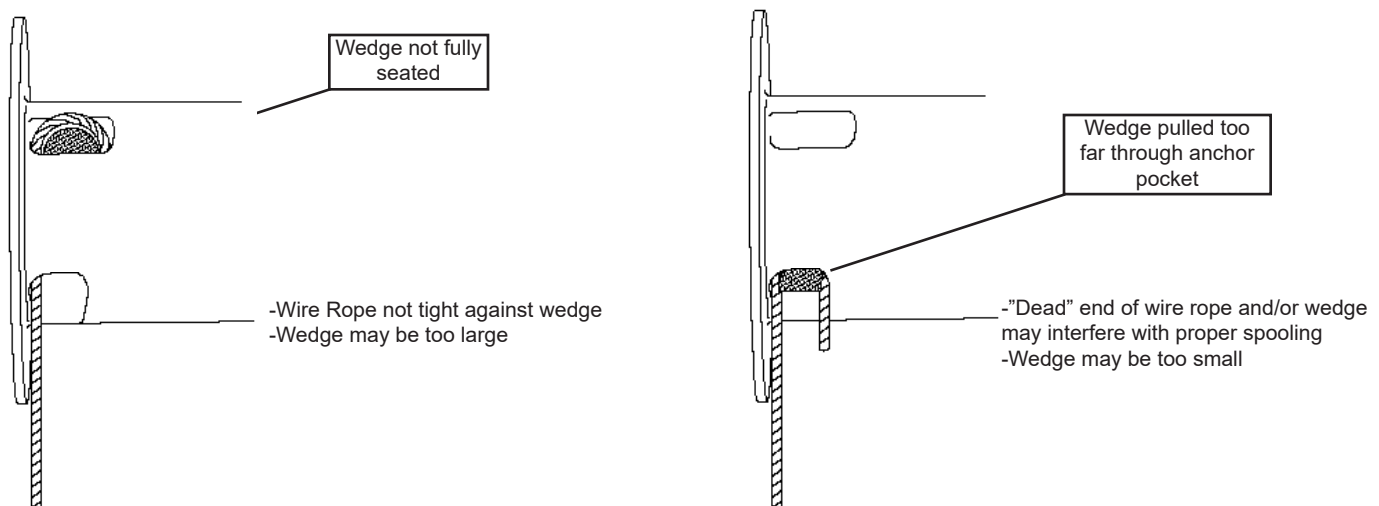

---

## HOIST OPERATION

---

The following warnings and instructions are basic to safe hoist operation. Please read them carefully and follow them each time your hoist is operated. These instructions are provided in addition to any information furnished by the original equipment manufacturer. Equipment operators should be completely familiar with the overall operation of the piece of equipment on which the hoist is mounted (such as crane, truck crane, etc.). If you have any questions concerning the safe operation of this hoist or the equipment it is mounted on, contact the equipment manufacturer that installed the hoist, or the PACCAR Winch Service Department at 918-251-8511, Monday through Friday, 8:00 a.m. to 4:30 p.m. (CST), [www.paccarwinch.com](http://www.paccarwinch.com).

### ⚠ WARNING ⚠

Ground personnel must stay in view of operator and clear of the load and hoist drum at all times. **DO NOT** allow personnel near the hoist line under tension. **DO NOT** allow personnel near the hoist drum while hoist is in operation. **DO NOT** allow personnel to be in line with the load or to stand under a suspended load. A safe distance of at least 1-1/2 times the working length of the cable should be maintained by ground personnel. A broken cable and/or lost load may cause property damage, personal injury, or death.

### ⚠ WARNING ⚠

Failure to properly warm up the hoist, particularly under low ambient temperature conditions, may result in temporary brake slippage due to high back pressures attempting to release the brake, which could result in property damage, severe personal injury, or death.

#### Warm-up Procedures

A warm-up procedure is recommended at each start-up and is essential at ambient temperatures below +40°F (4°C).

The engine should be run at its lowest recommended RPM with the hydraulic hoist control valve in neutral allowing sufficient time to warm up the system. The hoist should then be operated at low speeds, raise and lower with no load on the hook, several times to prime all lines with warm hydraulic oil, and to circulate gear lubricant through the planetary gear sets.

### ⚠ CAUTION ⚠

If the hoist is mounted on a crane that has an extendable boom, care must be taken to pay-out cable as the boom is extended. Failure to pay-out sufficient cable could result in a two-blocking condition that could result in damage to and/or failure of the hoist, cable, sheaves and/or boom.

### ⚠ WARNING ⚠

Failure to use the proper type and viscosity of planetary gear oil may contribute to intermittent brake clutch slippage which could result in property damage, severe personal injury, or death. Some gear lubricants contain large amounts of extreme-pressure (EP) and antifriction additives which may contribute to brake slippage and damage to brake friction discs or seals. Oil viscosity with regard to ambient temperature is also critical to reliable brake operation. Our tests indicate that excessively heavy or thick gear oil may contribute to intermittent brake slippage. Make certain that the gear oil viscosity used in your hoist is correct for your prevailing ambient temperature.

After the hoist/boom is properly positioned, we recommend the operator slowly pay-out, then haul-in a short length of cable. The hoist should perform these operations in a smooth and controlled manner. If the hoist does not operate smoothly or makes any unusual sounds, the source of the problem should be identified and corrected before any attempt is made to lift a load.

Slowly pay-out wire rope from the hoist drum until it reaches the load. Securely fasten the hoist cable to the load and be sure all ground personnel are a safe distance from the load. Slowly lift the load a short distance and stop. A small amount of bounce may be observed, depending on the weight of the load, size and type of wire rope, reaving and the amount of boom extension. Allow the load to stabilize and then watch for any sign of downward movement or cable drum rotation. The hoist static brake should hold the load in place without allowing any downward movement at all. If the load creeps down, it should be lowered to the ground immediately and the source of the problem identified and corrected.

If the hoist is holding the load securely, proceed with normal operations in accordance with the equipment manufacturer's operating procedures and load charts.

# HYDRAULIC CIRCUIT

**NOTE:** The hydraulic circuit shown below is representative of typical BRADEN hoists. Options and accessory equipment may result in changes to the circuit shown. For questions regarding the hydraulic circuit, refer to information supplied by the original equipment manufacturer, or contact the BRADEN Product Support Department at the number given in the Foreword of this manual. ALWAYS have the hoist model and serial number handy when contacting the factory.

**SINGLE-SPEED MOTOR CIRCUIT**

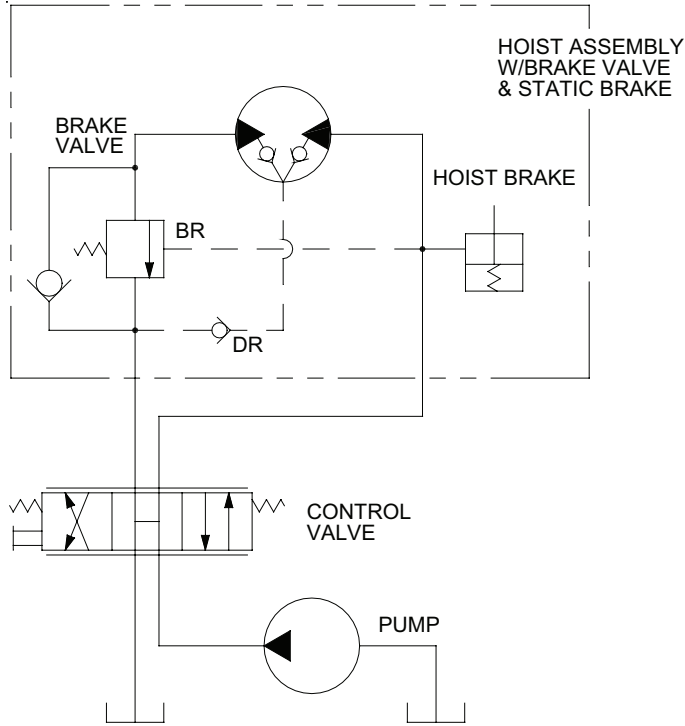

**TWO-SPEED MOTOR CIRCUIT**

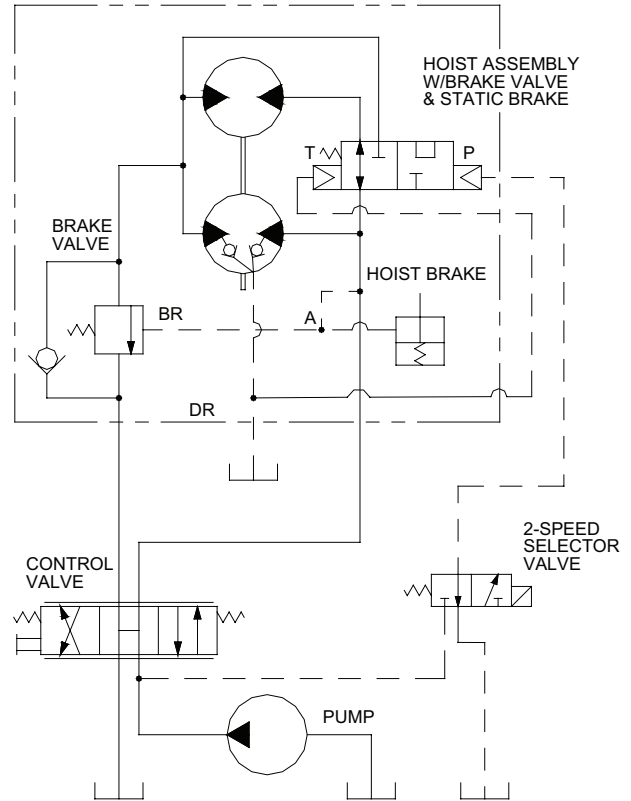

# RECOMMENDED FASTENER TORQUE

The general-purpose torque shown in the chart applies to SAE Grade 5 and Grade 8 bolts, studs and standard steel, full, thick and high nuts. Higher or lower torques for special applications will be specified such as the use of spanner nuts, nuts on shaft ends, jam nuts, and where distortion of parts or gaskets is critical. Lubricated torque values based on use of SAE 30 engine oil applied to threads and face of bolt or nut.

Bolt Diam. Inches	Thread per inch	Torque LB-FT (N.m)			
		Grade 5		Grade 8	
		Dry	Lubed	Dry	Lubed
1/4	20	8	6	12	9
	28	(11)	(8)	(16)	(12)
5/16	18	17	13	24	18
	24	(23)	(17)	(33)	(24)
3/8	16	31	23	45	35
	24	(42)	(31)	(61)	(47)
7/16	14	50	35	70	50
	20	(68)	(47)	(95)	(68)
1/2	13	75	55	110	80
	20	(102)	(75)	(149)	(108)
9/16	12	110	80	150	110
	18	(149)	(108)	(203)	(149)
5/8	11	150	115	210	160
	18	(203)	(156)	(285)	(217)

Bolt Diam. Inches	Thread per inch	Torque LB-FT (N.m)			
		Grade 5		Grade 8	
		Dry	Lubed	Dry	Lubed
3/4	10	265	200	380	280
	16	(359)	(271)	(515)	(380)
7/8	9	420	325	600	450
	14	(569)	(441)	(813)	(610)
1	8	640	485	910	680
	14	(868)	(658)	(1234)	(922)
1 1/8	7	790	590	1290	970
	12	(1071)	(800)	(1749)	(1315)
1 1/4	7	1120	835	1820	1360
	12	(1518)	(1132)	(2468)	(1817)
1 3/8	6	1460	1095	2385	1790
	12	(1979)	(1485)	(3234)	(2427)
1 1/2	6	1940	1460	3160	2370
	12	(2360)	(1979)	(4284)	(3214)

---

## PREVENTIVE MAINTENANCE

---

A regular program of preventive maintenance for your planetary hoist is required to minimize the need for emergency servicing and promote safe, reliable hoist operation.

The user of BRADEN hoist products is responsible for hoist inspection, testing, operator training and maintenance noted below with frequency dependent upon the severity of the hoist duty cycle and the thoroughness of the preventive maintenance program. Field experience, supported by engineering tests, indicate the three service procedures listed below are the most critical to safe, reliable hoist operation and **MUST** be observed.

- Regular Gear Oil Changes
- Use of Proper Gear Oil — recommended type for prevailing ambient temperatures and additives.
- Periodic Disassembly and Inspection of All Wear Components — in compliance with ANSI specification B30.5c, 1987 and API RP 2D.

Crane inspection records as well as records of preventive maintenance, repairs and modifications must be available for a minimum of five years. These records should include but not limited to, hoist model and serial number, name and employer of repair technician, date and description of work performed.

**Pre-use Inspection** (each shift the hoist is used): This inspection must be performed prior to placing the crane into service and then as necessary during the day for extended operation.

1. Check for external oil leaks and repair as necessary. **This is important due to the accelerated wear that can be caused by insufficient lubricating oil in the hoist.** Lubricant level must be visible in the lower half of the sight glass. Use only recommended lubricants. See Recommended Lubricants chart in this manual.
2. Check hydraulic plumbing for damage, such as chafed or deteriorating hoses and repair as necessary.
3. Visually inspect for loose or missing bolts, pins, keepers or cotter pins and replace or tighten as necessary.
4. The gear oil should be changed after the first 100 hours of operation or 30 days. The regular gear oil change intervals may be adopted after the first oil change.
5. Inspect the full length of wire rope, rigging and all sheaves according to the wire rope and crane manufacturer's recommendations.
6. A warm-up procedure is recommended at each start-up and is mandatory at ambient temperatures below +40°F (4°C). The engine should be run at its lowest RPM with the hydraulic hoist control in neutral allowing sufficient time to warm up the system. The hoist should then be operated at low speeds, hoisting and lowering

with no load, several times to prime all hydraulic lines with warm oil and to circulate lubricant through the planetary gear sets.

### **WARNING**

Failure to properly warm up the hoist, particularly under low ambient temperature conditions, may result in temporary brake slippage due to high back pressures attempting to release the brake, which could result in property damage, severe personal injury or death.

**Quarterly Inspection** (every 3 months) or monthly in Severe Duty Applications or prior to placing the machine in service if it has not been used for three months or more.

1. Perform the Pre-use Inspection.
2. Inspect all hoist fasteners for tightness and corrosion. Replace all corroded fasteners and tighten per the torque specifications on page 12.
3. The hydraulic system filters should be changed after the first 50 hours of operation then every 500 hours or quarterly or in accordance with the crane manufacturer's recommendations.
4. Take a sample of the gear oil from the hoist drum following the oil sampling procedure on page 15. The oil sample must be taken prior to changing the gear oil. Analyze the sample for wear metals, viscosity, signs of overheating, oxidation, water and other contaminants. If the oil sample contains an unusual amount of metallic particles, the hoist should be removed from service and undergo a teardown inspection.

**Annual Inspection, Testing and Preventive Maintenance** or semiannually in Severe Duty Applications.

1. Perform the Pre-Use and Quarterly Inspections.
2. Change the lubricating oil in the hoist drum after an oil sample is taken.

### **WARNING**

The gear oil must be changed to remove wear particles that impede reliable and safe operation of the brake clutch and erode bearings and seals. Failure to change gear oil at recommended intervals may contribute to intermittent brake slippage, loss of load control, injury, or death.



The gear oil should be changed whenever the ambient temperature changes significantly and an oil from a different viscosity range would be more appropriate. Oil viscosity is critical to reliable brake clutch operation. Our tests indicate that excessively heavy or thick gear oil may contribute to intermittent brake clutch slippage. Make certain the gear oil viscosity used in your hoist is correct for your prevailing ambient temperature.

## ⚠ WARNING ⚠

Failure to use the proper type and viscosity gear oil may result in loss of load control, property damage, injury or death.

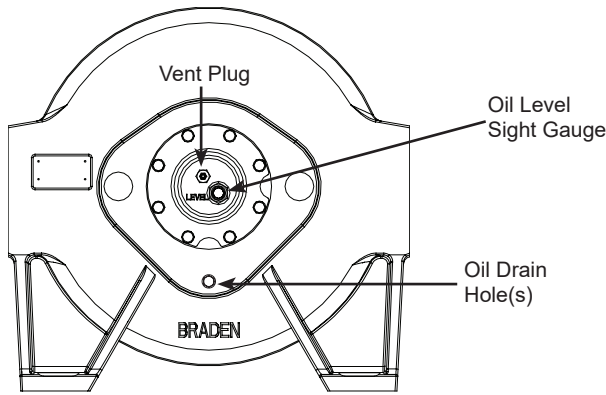

**NOTE:** If the oil sampling/analysis has not been performed as required, teardown inspections will be required. Refer to Hoist Disassembly section of this manual.

To change the gear oil, slowly rotate the drum until the oil drain plug is aligned with the lower oil port access hole. Install a short length of pipe threaded for 1-inch NPT into the threaded drain port in the cable drum. Reach through the pipe with a long hex-key and remove the drain plug. The oil will drain out the length of pipe and not between the drum and base. When the oil has drained, install the plug and remove the drain pipe. Removing the vent plug will hasten the oil drain. Rotate the drum until the drain port is aligned with the fill/level port in the end bracket. Refill the hoist with recommended lubricant. Install the plug securely.

3. The vent plug is located in the drum bearing support. It is important to keep the vent plug clean and unobstructed. Whenever the gear oil is changed, the vent plug should be removed, cleaned in solvent and reinstalled. Do not paint over the vent plug or replace with a solid plug or grease fitting.

## ⚠ WARNING ⚠

**DO NOT** insert fingers through oil drain hole to determine drain hole alignment. Movement of the drum could result in severe injury if fingers are present in the drain hole.

## RECOMMENDED PLANETARY GEAR OIL

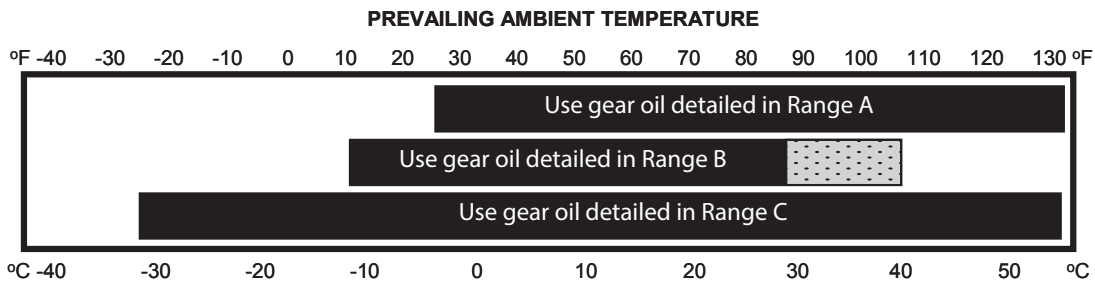

**SHADED TEMPERATURE RANGE IN THE CHART ABOVE NOT RECOMMENDED FOR SEVERE APPLICATIONS SUCH AS SUSTAINED FAST DUTY CYCLES OR FREQUENT WINCHING.**

Winches are factory filled with Mobilgear 600 XP 150 or equivalent. Consult your oil supplier for other equivalent oils if required.

	Mobil	Shell	Chevron	Texaco
Range A	Mobilgear 600 XP 220	Omala S2 G 220	Gear Compounds EP 220	Meropa 220
Range B	Mobilgear 600 XP 150	Omala S2 G 150	Gear Compounds EP 150	Meropa 150
Range C	Mobilgear SHC 150	Omala S4 GX 150		

## ⚠ WARNING ⚠

Failure to use the proper type and viscosity of planetary gear oil may contribute to intermittent brake clutch slippage which could result in property damage, severe personal injury, or death. Some gear lubricants contain large amounts of extreme-pressure (EP) and antifriction additives which may contribute to brake slippage and damage to brake friction discs or seals. Oil viscosity with regard to ambient temperature is also critical to reliable brake operation. Our tests indicate that excessively heavy or thick gear oil may contribute to intermittent brake slippage. Make certain that the gear oil viscosity used in your hoist is correct for your prevailing ambient temperature.

### Teardown Inspection

Any hoist that has not been subjected to regular oil sample analysis should undergo a teardown inspection every 24 months. Also, if a hoist has an unknown history of repair and/or maintenance, the hoist should undergo a teardown inspection prior to being placed into service.

A teardown inspection of the hoist should include the complete disassembly, cleaning, inspection and replacement of all worn, cracked, corroded or distorted parts such as pins, bearings, shafts and brake components. All seals and O-rings should be replaced

during a teardown inspection. Always use new spiro pins in the planet gear shafts.

### Any deficiency must be corrected immediately.

Before placing the hoist back in service, the rebuilt hoist must be pull tested to the rated load of the hoist with a dynamometer or equivalent measuring device. The hoist should be dynamically tested by rotating the drum several times, in both raising and lowering directions, while under load of at least 30% of the hoist rated lifting capacity. Check for smooth, quiet operation during this procedure.

---

## OIL SAMPLING AND ANALYSIS

---

Proper oil sampling and analysis of the sample, is a vital part of a comprehensive preventive maintenance program. Information obtained from the oil analysis is best utilized in conjunction with a regular program of preventive maintenance. The early warning of abnormal wear provided by an analysis program allows the user to substitute preventive maintenance for a far more costly and dangerous failure that may lead to loss of load control that could result in property damage, personal injury, or death. Early detection of accelerated component wear allows the scheduling of corrective maintenance and can reduce in-operation failures and costly down time.

### Taking a Valid Oil Sample

Prepare the hoist by cleaning the drain area and drain extension tube in order to obtain an uncontaminated sample. Operate the hoist in both directions for one to two minutes and then take the oil sample from the drain port as soon as possible. Do not take the sample from the first oil out of the drain port. Take a sample from the mid-stream flow of the oil to obtain an accurate representation of the oil condition. After taking an oil sample, refill hoist with recommended lubricant.

### Analysis

#### General Guidelines

(After approximately 250 hours of operation)

**NOTE:** The first oil change usually contains more wear metals. Following the initial break-in period, the wear metal levels should stabilize at a lower number.

#### Iron Contaminants

100 to 400 ppm Normal

400 to 700 ppm Caution — Abnormal sample (monitor more frequently), teardown inspection may be required

701 ppm and up Unacceptable — Abnormal sample (teardown inspection required)

In all contaminant monitoring, equally important as the level of contamination, is the change in the amount of contamination compared to previous samples.

Moisture contamination will lead to the formation of acids that damage all internal components. Silica found in the oil typically indicates dirt and contaminated lubricant supply or poor maintenance practices.

## ⚠ WARNING ⚠

Hot oil may cause personal injury and/or burns to unprotected skin. Make certain oil has cooled to a safe temperature (less than 110°F or 43°C) before taking oil sample, changing oil, or servicing hoist.



## TROUBLESHOOTING

The following troubleshooting section is provided as a general guide. You may also need to contact the original equipment manufacturer (OEM) for additional information.

### ⚠ WARNING ⚠

**If a hoist exhibits any sign of:**

- Erratic operation such as poor load control, load creeping down or chattering
- Unusual noise or gear oil leaks
- A sudden increase in wear particles from oil analysis

The hoist **MUST** be removed from service until the problem has been corrected. If a hoist has been subjected to a sudden heavy load (shock-load) or overload, the hoist must be removed from service, disassembled and all internal components thoroughly inspected for damage. Continued operation with a defect may result in loss of load control, property damage, injury, or death.

TROUBLE	PROBABLE CAUSE	REMEDY
<p style="text-align: center;"><b>A</b></p> <p>The hoist will not lower the load or not lower the load smoothly.</p>	<p>1. The problem could be a plugged or loose pilot orifice. The pilot orifice is a small pipe plug with a hole drilled through it, located behind the pilot port fitting on the brake valve. If the orifice becomes plugged, it will prevent the pilot pressure, from the manifold, from opening the brake valve. If the plug becomes loose, it will allow an unregulated amount of oil in to operate the brake valve causing erratic brake valve operation.</p> <p><b>NOTE:</b> Some brake valves do not use a separate pilot orifice plug.</p> <p>2. The friction brake may not be releasing as a result of a defective brake cylinder seal.</p> <p><b>NOTE:</b> If the brake cylinder seal is defective you will usually find oil leaking from the hoist vent plug.</p> <p>3. Friction brake will not release as a result of damaged brake discs.</p>	<p>Remove the pilot hose and fitting from the brake valve, then use a 5/32-inch Allen wrench to remove the pilot orifice. The diameter of the orifice is approximately .020 inches (.5 mm). Clean and install the pilot orifice tightly in the brake valve.</p> <p>Check brake cylinder seal as follows:</p> <p>A. Disconnect the swivel tee from the brake release port. Connect a hand pump with accurate 0-2000 PSI (13,800 kPa) gauge and shut-off valve to the fitting in the brake release port.</p> <p>B. Apply 1000 PSI (6,900 kPa) to the brake. Close shut-off valve and let stand for five minutes.</p> <p>C. If there is any loss of pressure in five minutes, the brake cylinder should be disassembled for inspection of the sealing surfaces and replacement of the seals. Refer to Brake Cylinder Service section of this manual.</p> <p>Disassemble brake to inspect brake discs. Check stack-up height as described in Brake Cylinder Service section of this manual.</p>

TROUBLE	PROBABLE CAUSE	REMEDY
<p align="center"><b>B</b></p> <p>Oil leaks from vent plug</p>	<ol style="list-style-type: none"> <li>1. Same as A2.</li> <li>2. Motor seal may be defective as a result of high back pressure in the motor case drain circuit or contaminated oil. Contamination will usually cause the seal to wear a groove in the motor shaft.</li> </ol>	<p>Same as A2.</p> <p>Case drain back pressure must not exceed 100 PSI (690 kPa) for gear motors and 44 PSI (304 kPa) for piston motors. Inspect hydraulic system for a restriction in the return line to the reservoir.</p> <p>Oil analysis may indicate contamination has worn motor shaft and seal. Thoroughly flush entire hydraulic system and install new filters and oil. Install new motor shaft seal.</p>
<p align="center"><b>C</b></p> <p>The brake will not hold a load with the control lever in neutral</p>	<ol style="list-style-type: none"> <li>1. Excessive system back pressure acting on the brake release port.</li> <li>2. Friction brake will not hold due to worn or damaged brake discs.</li> <li>3. Brake clutch is slipping.</li> </ol>	<p>The pressure at the motor lowering port is also transmitted to the brake release pilot circuit. Inspect hydraulic circuit for restrictions, plugged filters or control valves not centering.</p> <p>Same as Remedy of Trouble A3.</p> <p>Improper planetary gear oil may cause the brake clutch to slip. Drain old gear oil and flush winch with solvent. Thoroughly drain solvent and refill hoist with recommended planetary gear oil listed in Preventive Maintenance.</p> <p>Brake clutch may be damaged or worn. Disassemble and inspect brake clutch as described in Overrunning Clutch Service.</p>
<p align="center"><b>D</b></p> <p>The hoist will not hoist the rated load</p>	<ol style="list-style-type: none"> <li>1. The hoist may be mounted on an uneven or flexible surface which causes distortion of the hoist base and binding of the gear train. Binding in the gear train will absorb horsepower needed to hoist the rated load and cause heat.</li> <li>2. System relief valve may be set too low. Relief valve needs adjustment or repair.</li> </ol>	<p>Reinforce mounting surface.</p> <p>If necessary, use shim stock to level hoist. Refer to Hoist Installation. First loosen, then evenly retighten all hoist mounting bolts to recommended torque.</p> <p>Check relief pressure as follows:</p> <p>A. Install an accurate 0-5000 PSI (34,500 kPa) gauge into the inlet port of the brake valve.</p>

TROUBLE	PROBABLE CAUSE	REMEDY
<p>Trouble D Continued From Previous Page</p>	<p>3. Be certain hydraulic system temperature is not more than 180°F (82°C). Excessive hydraulic oil temperatures increase motor internal leakage and reduces motor performance.</p> <p>4. Hoist line pull rating is based on 1st layer of wire rope.</p> <p>5. Rigging and sheaves not operating efficiently.</p>	<p>B. Apply a stall pull load on the hoist while monitoring pressure.</p> <p>C. Compare gauge reading to hoist specifications. Adjust relief valve as required.</p> <p><b>NOTE:</b> If pressure does not increase in proportion to adjustment, relief valve may be contaminated or worn out. In either case, the relief valve may require disassembly or replacement.</p> <p>Same as remedies for Trouble D1 and D2.</p> <p>Same as remedies for Trouble E2.</p> <p>Refer to hoist performance charts for additional information.</p> <p>Perform rigging service as recommended by crane manufacturer.</p>
<p><b>E</b></p> <p>The winch runs hot</p>	<p>1. Same as D1.</p> <p>2. Be certain that the hydraulic system temperature is not more than 180°F (82°C). Excessive hydraulic oil temperatures may be caused by:</p> <p>A. Plugged heat exchanger.</p> <p>B. Too low or too high oil level in hydraulic reservoir.</p> <p>C. Same as D2</p> <p>D. Hydraulic pump not operating efficiently.</p> <p>E. Hydraulic oil is wrong viscosity for operating conditions.</p> <p>3. Excessively worn or damaged internal winch parts.</p>	<p>Same as remedies for Trouble D1.</p> <p>Thoroughly clean exterior and flush interior.</p> <p>Fill/drain to proper level.</p> <p>Same as remedies for Trouble D2.</p> <p>Engine low on horsepower or RPM Tune/adjust engine.</p> <p>Check suction line for damage.</p> <p>Pump worn. Replace pump.</p> <p>Use correct hydraulic oil.</p> <p>Disassemble hoist to inspect/ replace worn parts.</p>

TROUBLE	PROBABLE CAUSE	REMEDY
<p style="text-align: center;"><b>F</b></p> <p>Hoist chatters or surges while raising rated load.</p>	<ol style="list-style-type: none"> <li>1. Same as D1</li> <li>2. Same as D2.</li> <li>3. Hydraulic oil flow to motor may be too low.</li> <li>4. Controls being operated too quickly.</li> <li>5. Hydraulic motor two-speed control not shifting correctly.</li> </ol>	<p>Same as remedies for Trouble D1</p> <p>Same as remedies for Trouble D2.</p> <p>Same as remedies for Trouble E2.</p> <p>Conduct operator training as required.</p> <p>Inspect and repair motor displacement control.</p>
<p style="text-align: center;"><b>G</b></p> <p>The wire rope does not spool smoothly on the drum.</p>	<ol style="list-style-type: none"> <li>1. The hoist may be mounted too close to the main sheave, causing the fleet angle to be more than 1-1/2 degrees.</li> <li>2. The hoist may not be mounted perpendicular to an imaginary line between the center of the cable drum and the first sheave.</li> <li>3. Could possibly be using the wrong lay rope. There is a distinct advantage in applying rope of the proper direction of lay. When the load is slacked off, the several wraps on the drum will stay closer together and maintain an even layer. If rope of improper lay is used, the coils will spread apart each time the load is removed. Then, when hoisting is resumed, the rope has a tendency to criss-cross and overlap on the drum. The result is apt to be a flattened and crushed rope.</li> <li>4. The hoist may have been overloaded, causing permanent set in the wire rope.</li> </ol>	<p>Check mounting distance and fleet angle. Reposition hoist as required to achieve 1/2 to 1-1/2 degree fleet angle.</p> <p>Refer to Hoist Installation.</p> <p>Consult wire rope manufacturer for recommendation of wire rope that best suits your application.</p> <p>Replace wire rope and conduct operator/rigger training as required.</p>

## DISASSEMBLY PROCEDURE

1. Remove the wire rope from the hoist drum and wind onto a cable reel as recommended by the wire rope manufacturer. Power-wash the hoist and all motor piping to remove contamination that might enter open hose and motor ports. Align the drain plug in the cable drum with the lowest access hole in the bearing support end plate before removing the hoses and piping. Drain the gear oil from the hoist as described in the Preventive Maintenance section of this manual.

### ⚠ CAUTION ⚠

The CH Series hoist with the standard 01 drum weighs up to 1100 pounds (500 kg). Ensure that lifting equipment has adequate capacity. Using undersized or poorly maintained lifting equipment may result in a dropped load, property damage, injury, or death.

### ⚠ CAUTION ⚠

**DO NOT** attempt to disassemble/assemble hoist in the horizontal position as thrust washers may become dislodged and the gear train misaligned. Severe gear train damage may result in loss of load control, property damage, injury, or death.

2. Stand the winch up on the drum bearing support end with the motor end up. Secure the hoist in this position so that it does not fall over and cause property damage or personal injury.
3. Tag and remove the hydraulic hoses that connect the brake valve and motor to the brake release port.

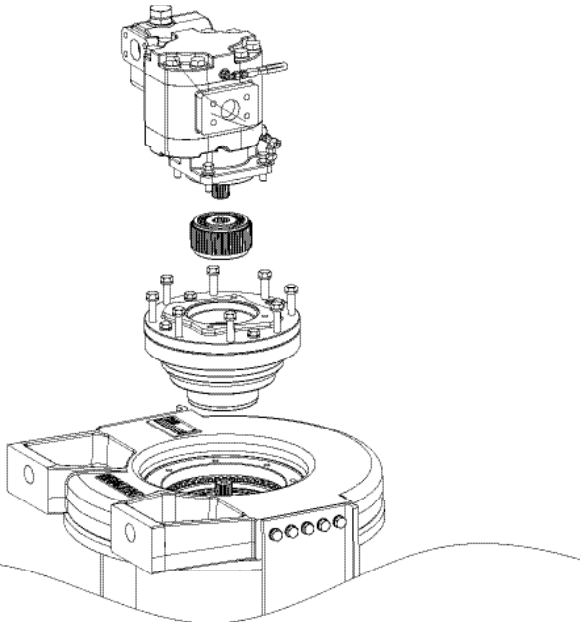

4. Remove the four capscrews and lockwashers securing the motor and lift the motor off the hoist. Cover the motor ports to prevent contamination. Remove the brake clutch assembly from the brake

cylinder. Disassembly of the brake clutch assembly will be discussed in the Brake Clutch Service section of this manual.

5. Remove the eight capscrews that secure the brake cylinder to the motor side plate. Lift the brake cylinder out of the hoist and place on a clean work surface. Disassembly of the brake cylinder will be discussed in the Brake Cylinder Service section of this manual. Remove and discard the V-ring seal (Item 20) that was under the brake cylinder (CH165 and CH230 only). Do not remove the four capscrews holding the motor adapter to the brake cylinder at this time. Refer to Brake Cylinder Service later in this manual.

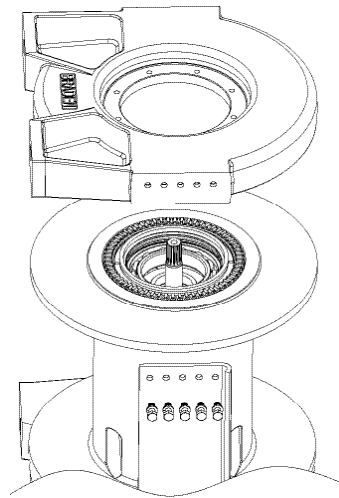

6. Remove the 20 capscrews and lockwashers from the two tie plates, and remove the plates.
7. Remove the motor end plate from the drum.

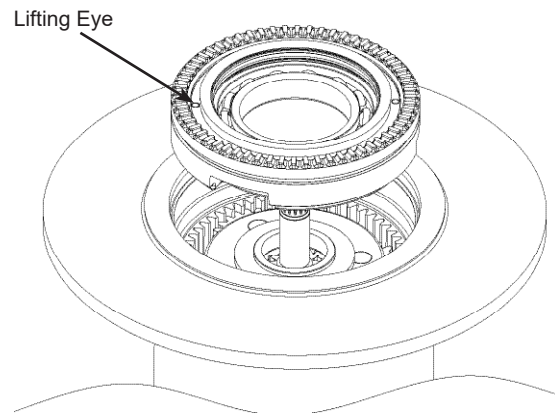

8. There are two (CH165 and CH230) 1/2-inch NC tapped holes in the drum closure (Item 33). Install two capscrews or threaded eye-bolts to aid in removing the closure from the cable drum. Remove and discard the O-ring (Item 17) from the outer diameter of the drum closure.

---

## DISASSEMBLY PROCEDURE

---

9. For -01 and -02 drums, the primary sun gear (Item 22), primary planet carrier assembly (Item 300), and output planet carrier assembly (Item 400) can now be lifted out of the cable drum.  
  
For -02 drums only, there are also two 1/2-inch NC tapped holes in the ring gear adapter (Item 33). Install two capscrews or threaded eye-bolts into these holes and lift the ring gear adapter and ring gear out of the cable drum.
10. Lift the cable drum (Item 10) off of the drum support assembly (Item 3).
11. Remove the 8 capscrews securing the bearing support (Item 3) to the support side plate (Item 8) and remove the bearing support. Remove and discard the V-ring seal (CH165/ CH230 only). Remove and discard the lip seal from the support end of the cable drum (Item 6).
12. Thoroughly clean and inspect all disassembled components at this time. Inspect bearings in the drum closure and cable drum (Items 9 and 16), and replace as required. Inspect sealing surfaces on the drum support and brake cylinder and repair any damaged areas if possible, or replace components as required. During a complete winch teardown, drum seals (Items 18 and 70) and V-ring seals (Items 6 and 20) should always be replaced. Inspect thrust washers (Items 13 and 15) for signs of excessive wear, heat damage or metal transfer and replace as necessary. Inspect the ring gear teeth for nicks, spalling or excessive wear. Replace if wear in contact areas is greater than 0.015 inch (0.4 mm) when compared to unworn area of teeth.





## PLANET CARRIER SERVICE

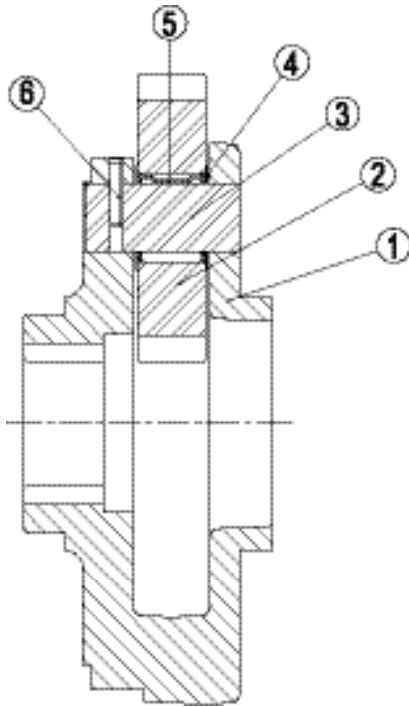

### PRIMARY PLANET CARRIER Disassembly

1. Remove the planet gears by first driving the roll pins (6) into the center of the planet gear shafts (3). Push the planet gear shafts far enough out of the planet carrier to expose the roll pin hole. Use a pin punch to drive the roll pins from the shafts. **DO NOT** reuse roll pins
2. Now you can remove the planet shafts, bearings, thrust washers and gears. Thoroughly clean all parts and inspect for damage and wear. The bearing rollers should not exhibit any irregularities. If the rollers show any sign of spalling, corrosion, discoloration, material displacement or abnormal wear, the bearing should be replaced. Likewise, the cage should be inspected for unusual wear or deformation, particularly the cage bars. If there is any damage that will impair the cage's ability to separate, retain and guide the rollers properly, the bearing should be replaced. The thrust washer contact areas should be free from any surface irregularities that may cause abrasions or friction. The gears and shafts should be inspected for abnormal wear or pitting. Replace if necessary

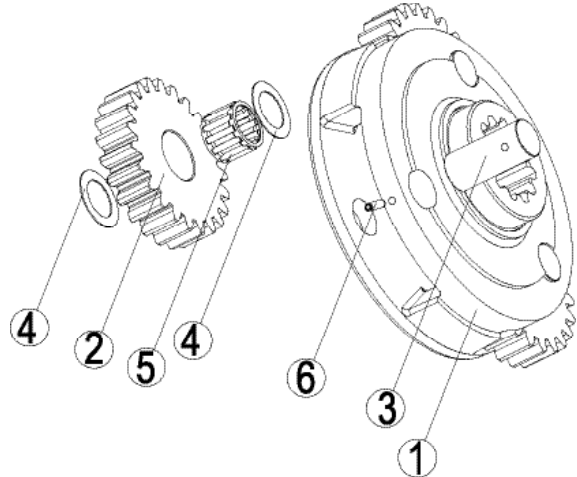

### Assembly

1. Install a bearing (5) into a planet gear (2) and place a thrust washer (4) on each side of the gear. Position this subassembly into an opening in the carrier. Slide a planet gear shaft (3) through the carrier (1), thrust washer (4), bearing (5) and remaining thrust washer (4). **DO NOT** drive shafts into carrier with a hammer. Shafts should move freely when properly aligned.

### ⚠ CAUTION ⚠

Driving planet shafts with a hammer may damage the hardened thrust washers. This could lead to catastrophic gear train failure resulting in loss of load control, property damage, injury, or death.

2. Carefully align the pin hole in the carrier with the hole in the shaft and drive a new roll pin into place. **ALWAYS** use **NEW** roll pins. When properly positioned, 50% of the roll pin will engage the planet gear shaft and 50% will remain in the carrier.

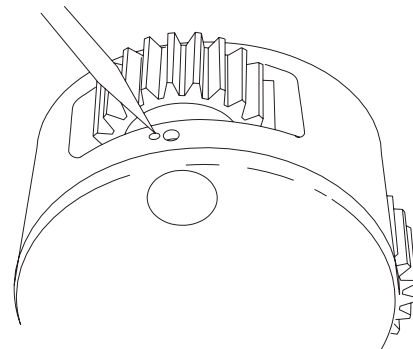

3. Note that the roll pin is slightly recessed into the carrier when properly installed. With a center punch, stake the carrier next to the pin hole as shown. This will distort the hole and prevent the pin from backing out in operation. Repeat these steps for each of the three planet gears.

## Assembly

### -01 DRUM

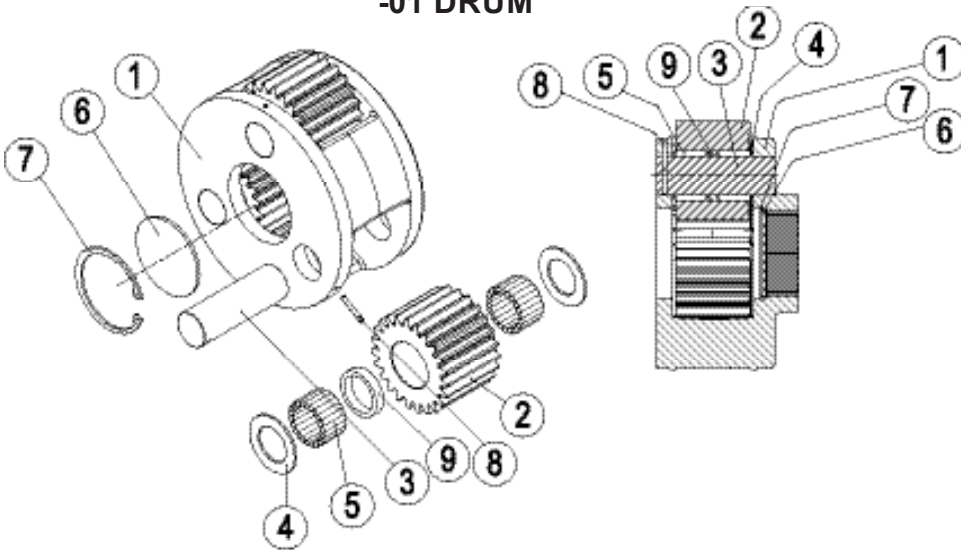

1. Place the output planet carrier on a clean work surface with the splined end of the housing down.

#### -01 Drums only-

Install the thrust plate (6) into the center bore of the housing and secure in place with retaining ring (7).

2. Apply oil soluble grease to a thrust washer (4) and install it on one side of a planet gear (2). Place the planet gear on a clean work surface with the thrust washer down. Apply oil soluble grease to the bore of the gear and stack a row of loose bearing rollers (5) into the planet gear using the grease to hold the rollers in position. There are 22 rollers (18 count in CH175B) in each row. Install a bearing spacer (9) into the gear. Install a second row of bearing rollers on top of the bearing spacer. Place the remaining thrust washer on top of the planet gear. Carefully slide the planet gear subassembly into the planet carrier. Install a planet gear shaft into the planet carrier and through the planet gear bearings. **DO NOT** drive shafts into carrier with a hammer. Shafts should move freely when properly aligned.

### -02 DRUM

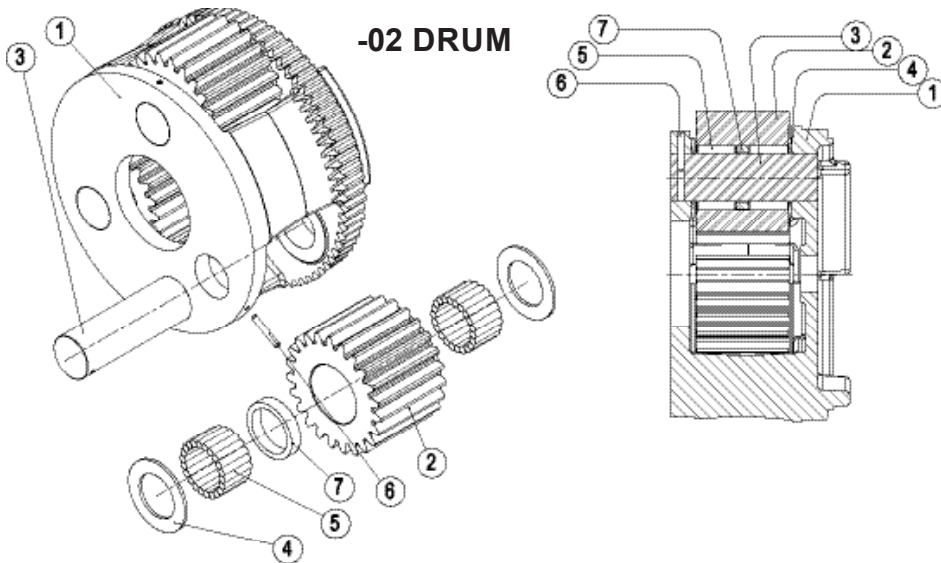

## OUTPUT PLANET CARRIER Disassembly

1. Remove the planet gears by first driving the roll pins (8) into the center of the planet gear shafts (3). Push the planet gear shafts far enough out of the planet carrier to expose the roll pin hole. Use a pin punch to drive the roll pins from the shafts. **DO NOT** reuse roll pins.
2. Remove planet shafts, bearing rollers, spacers, thrust washers and gears. Thoroughly clean all parts and inspect for damage and wear. The bearing rollers should not exhibit any irregularities. If rollers show any sign of spalling, corrosion, discoloration, material displacement, or abnormal wear, they should be replaced. The thrust washer contact areas should be free from any surface irregularities that may cause abrasions or friction. Gears and shafts should be inspected for abnormal wear or pitting and replaced if necessary.

3. Follow steps 2 and 3 of the Primary Planet Carrier assembly procedure to install and stake a NEW roll pin in the carrier.

Repeat this procedure for each of the planet gears.

## ⚠ CAUTION ⚠

Driving planet shafts with a hammer may damage hardened thrust washers. This could lead to catastrophic gear train failure resulting in loss of load control, property damage, injury, or death.

# OVERRUNNING CLUTCH SERVICE

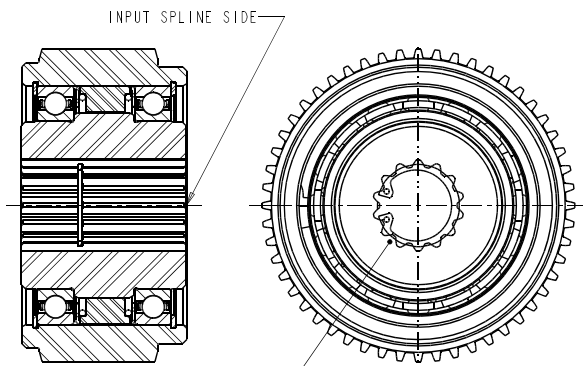

Input spline to rotate freely when viewed from input spline side

-01 drum input spline direction clockwise

-02/-21 drums input spline direction counter-clockwise

**NOTE:** Early production CH165A/CH230B hoists (built prior to November 2006) with -01 drums included overrunning clutch assemblies with the inner race (Item 50) rotated 180 degrees relative to the outer race (Item 42). When installing an overrunning clutch into an early unit, assemble as shown above to ensure the inner race rotates freely in the correct direction for the proper drum rotation direction, required.

## ⚠ WARNING ⚠

The polished surfaces of the inner and outer race and the overrunning cams must be perfectly smooth to ensure positive engagement of the clutch. The slightest defect may reduce clutch effectiveness, which may lead to loss of load control and result in property damage, injury, or death. It is recommended to replace the entire clutch assembly if any component is defective. For these reasons, the overrunning clutch assembly should be disassembled for inspection only if the hoist has exhibited any unusual operation that would point toward a clutch malfunction, or if the overrunning clutch assembly shows external signs of mechanical damage.

**NOTE:** Outer race (Item 42), Inner race (Item 50) and Overrunning clutch (Item 46) are NOT SOLD individually as replacement parts. If any of these parts require replacement, the entire overrunning clutch assembly must be replaced. Carefully note the relative orientation between the inner and outer races, and the direction of free rotation of the inner race. The clutch MUST be re-assembled correctly for proper hoist operation.

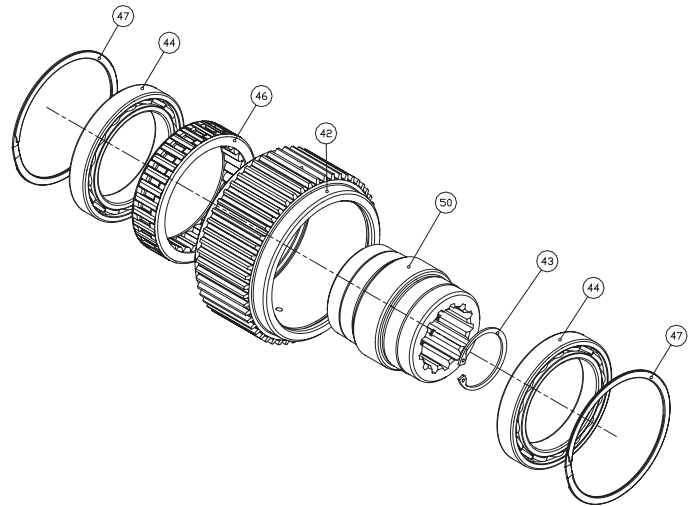

## Disassembly

1. Remove one of the retaining rings (Item 47) from the outer race (Item 42). Push the inner race (Item 50), bearings (Item 44) and overrunning clutch (Item 46) through the outer race.
2. Use a small punch and hammer to tap one of the bearings (Item 44) off of the inner race. The overrunning clutch can now be removed from the inner race. Closely inspect the overrunning clutch and the polished surfaces of the inner and outer race for wear, cracks, pitting, corrosion or mechanical damage. Closely inspect the bearings for any signs of damage, wear, corrosion, pitting or heat discoloration.

## Assembly

1. If both bearings (Item 44) have been removed from the inner race, install one of them now.
2. Install the overrunning clutch onto the inner race. Rotate the inner race slightly to get the clutch started onto the inner race.
3. Install the other bearing onto the inner race.
4. The outer race should have one retaining ring (Item 47) installed in one end. Carefully slide the inner race, with bearings and clutch, into the outer race. Install the other retaining ring into the outer race.

## ⚠ WARNING ⚠

Failure to assemble the overrunning clutch assembly with all parts oriented correctly may result in reduced brake effectiveness, which may lead to loss of load control and result in property damage, injury, or death.

# BRAKE CYLINDER SERVICE

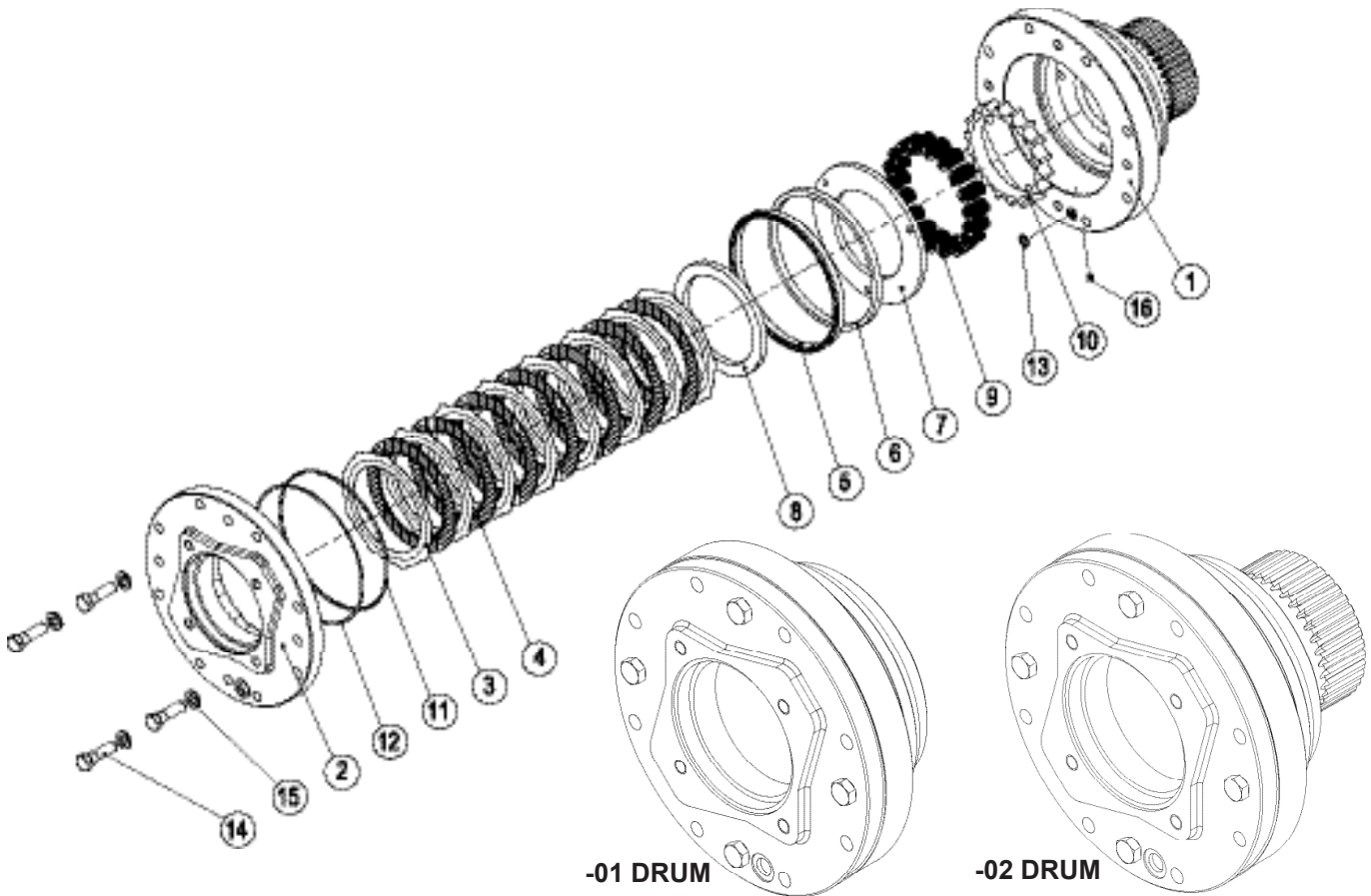

## Disassembly



The motor adapter is under spring tension from the brake springs. Loosen each of the capscrews one turn at a time until spring tension is released.

1. Stand the brake assembly on the splined end, with the motor adapter up. Remove the four capscrews (Item 14) and lockwashers (Item 15). Use a criss-cross pattern and loosen each capscrew one turn at a time until spring tension is released.
2. Remove the motor adapter (Item 2). Lift out all the brake discs (Item 3), friction discs (Item 40) and the spacer (Item 8).
3. Remove and discard the O-ring and backup ring (Items 11 and 12) from the motor adapter. Remove and discard the seal (Item 5) from the brake cylinder. Remove the steel piston backup ring (Item 6).
4. Remove the pressure plate (Item 7) and the springs and separator (Items 9 and 10) from the brake cylinder.

## Clean and Inspect

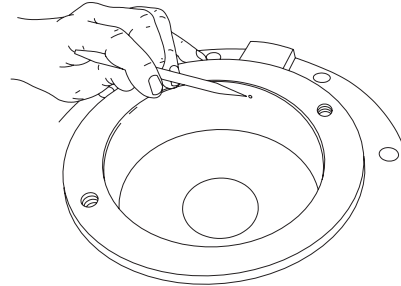

1. Thoroughly clean and inspect all parts at this time. Check sealing surfaces on both the motor adapter and brake cylinder. Be sure the brake release port is open and free of contamination.



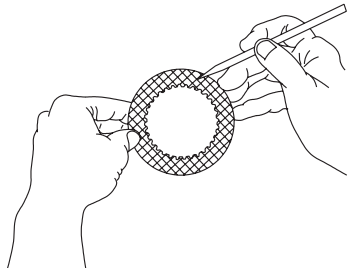

- Place friction brake disc on flat surface and check for distortion with a straight edge. Friction material should appear even across entire surface with groove pattern visible. Replace friction disc if splines are worn to a point, disc is distorted, friction material is burned or worn unevenly, or groove depth is less than 0.003 inch (0.08 mm).

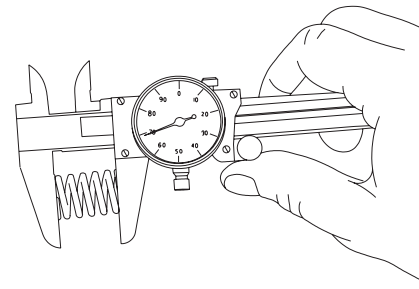

- Place steel disc on flat surface and check for distortion with a straight edge. Check surface for signs of material transfer or excessive heat. Replace steel disc if distorted, heat discolored, or mechanically damaged.
- Check brake spring free length. Minimum free length is 1-7/16 inch (36.5 mm). Check springs for signs of cracking or failure. If a brake spring must be replaced for any reason, then **ALL** brake springs must be replaced.

## ⚠ CAUTION ⚠

Failure to replace brake springs as a set may result in uneven brake application pressure and repeated brake spring failure.

## Assembly

- Place the motor adapter on a clean work surface with the motor mounting surface down. Apply a light coat of oil to a new backup ring (Item 12) and O-ring (Item 11) and install them into the groove on the motor adapter. Backup rings are always placed on the low pressure side of the O-ring. In this case, the backup ring is toward the motor mounting surface. Lightly oil the brake cylinder seal (Item 5) and install it onto the motor adapter with the seal lip down.
- Install a steel brake disc (Item 3) into the motor adapter, followed by a friction disc (Item 4). Continue to alternately install steel and friction discs until there are 8 steel and 7 friction discs. A steel disc will be on top.
- Install the brake plate spacer (Item 8) on top of the last steel disc.
- To check brake stack height, place pressure plate (Item 7) on top of brake spacer. Hold pressure plate down firmly by hand and measure gap (in three places) between motor adapter and pressure plate. Average gap must measure between 0.160 in. (4 mm) maximum and 0.080 in. (2.0 mm) minimum. If the gap exceeds the maximum limit, there may be too many discs in the stack-up or the discs are distorted. If the gap is less than the minimum, there may be too few discs or the discs are worn beyond their serviceable limit and should be replaced. When the gap is within minimum and maximum values, remove the pressure plate and all brake discs. Lubricate all friction discs with the same oil to be used in the hoist. Install all brake discs and brake plate spacer as described in steps 2 and 3.

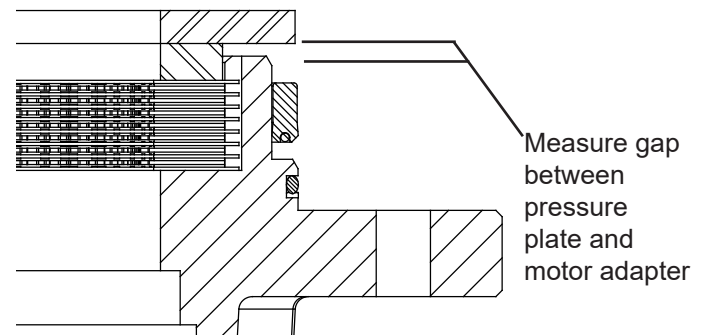
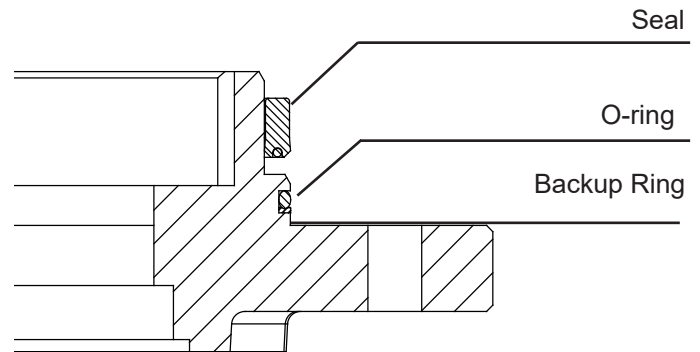

---

## BRAKE CYLINDER SERVICE

---

5. Place the brake cylinder on a clean work surface with the drum end down. Install the spring spacer (Item 10), then the 18 springs (Item 9).

### ⚠ WARNING ⚠

Always use the molded spring spacer to properly position the springs in the brake cylinder. Failure to install the spring spacer may allow the springs to contact each other and become damaged. This could result in loss of load control, property damage, injury, or death.

6. Install the pressure plate (Item 7) into the brake cylinder. Be careful that none of the springs fall over. Install the steel backup ring (Item 6). Apply an oil soluble grease to a new O-ring (Item 13) and install it in the brake housing.
7. Apply an oil soluble grease to the sealing surface of the brake cylinder and the piston seal. Turn the brake cylinder over and lower it onto the motor adapter, being careful not to damage the piston seal or O-ring on the adapter. Be careful the O-ring (Item 13) does not fall out of place, and the oil passages are aligned. The alternate assembly method below could also be used.
8. Turn the entire assembly over and install the four capscrews and lockwashers. After the capscrews make contact with the motor adapter, evenly tighten them one turn at a time until the motor adapter is drawn tight against the brake cylinder, then torque to the recommended value.

**NOTE:** The close fitting backup ring may be depressed slightly to one side to lodge it in the brake cylinder bore and temporarily hold the pressure plate and springs in place while the brake cylinder is inverted and lowered over the motor adapter.

As an alternate, the motor adapter and brake plates can be turned over and installed into the brake cylinder, holding the brake plates and spacer in place through the center opening. Be careful to not pinch your fingers between the spacer plate and the pressure plate.

## BRAKE CYLINDER PRESSURE TEST

1. Install a -6 ORB fitting into the brake release port on the motor adapter. Connect a hand pump with an accurate 0-2,000 PSI (0-13,800 kPa) gauge and shut-off valve to this fitting. Apply 1,000 PSI (6,900 kPa) to the brake and close the shut-off valve. Let the unit stand for five minutes. If there is any loss of pressure, the brake cylinder should be disassembled for inspection of the sealing surfaces, seal and O-ring. When the source of the pressure leak has been determined and corrected, re-assemble the brake cylinder and repeat the test.
2. WHILE PRESSURE IS APPLIED AND THE BRAKE IS RELEASED, install the overrunning clutch assembly into the brake pack. Turn the clutch back and forth to align the splines on all the friction discs. Release the pressure on the brake cylinder and remove the clutch assembly. The brake cylinder is now complete and ready to be installed in the hoist.

**THIS PAGE INTENTIONALLY LEFT BLANK**



# REVERSING DIRECTION OF DRUM ROTATION

090, 110, and 120 motors only

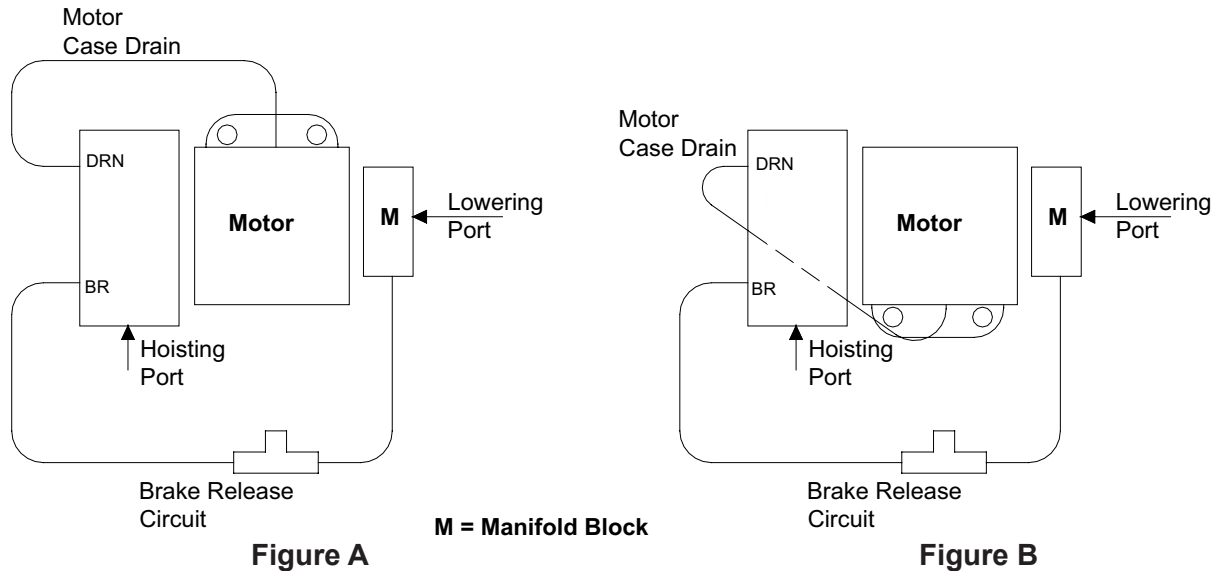

The following procedure applies to single-speed gear motors. For two-speed gear motors, the motor must be disassembled and the center section with the shift spool turned 180 degrees.

In order to change the direction of rotation, 2 things must be changed on the hoist. First, the motor hoist and lower directions of rotation must be changed to the opposite direction. This is done by exchanging positions of the brake valve and manifold block on the motor. Secondly, the brake clutch assembly must be made effective for the opposite direction of rotation. This is done by reversing the inner race of the brake clutch assembly.

Figures A and B above show typical CH165A/230B motor installations. Note that the only difference between the two drawings is the motor is rotated 180 degrees (the belly of the motor moves to the opposite side). If the motor shaft rotates clockwise in Figure A when the hoisting port is pressurized, it will rotate counterclockwise in Figure B.

1. Remove the four capscrews if equipped securing the brake valve to the motor. Remove the four capscrews securing the manifold block to the motor. Disconnect the motor case drain hose at the motor.

**NOTE:** Some installations have the brake release hose connected directly to the motor, instead of to the manifold block. In this case, disconnect the brake release hose at the motor port. Stand winch up on drum support with the motor end up and secure in this position.

2. Before removing the motor, it is a good idea to note or mark the position of the motor in relation to the winch, since it will be rotated 180 degrees when reinstalled. Rotating the motor allows the hoist and lowering hoses to connect on the same side of the hydraulic motor as in the previous setup. Remove the capscrews securing the motor to the winch and carefully remove the motor.
3. Remove the brake clutch assembly from the brake cylinder.
4. Remove the snap ring (47) from one-end of the brake clutch assembly and push the inner race out of the assembly. Refer to Overrunning Clutch Service section of this manual for drawings.
5. Use a punch to remove the bearing on one side of the inner race so the sprag assembly can be removed. Remove the sprag assembly and flip over so that the direction of free rotation is reversed.

**NOTE:** The sprag assembly is etched with arrows indicating both the free turn and lock direction.

6. Using a press or punch reinstall the bearing on the inner race.
7. Slide the inner race into the outer race while ensuring the sprag cams do not catch on the outer race. Install the snap ring and ensure it is fully seated in the groove.

### For -01 Drums

Before installing the brake clutch, be sure the inner race turns free in the opposite direction the drum will turn to haul-in wire rope. An easy way to check the rotation is to hold the outer race in one hand and rotate the inner race. Install the brake clutch with as shown in drawing on previous page.

### For -02 or -21 Drums

Before installing the brake clutch, be sure the inner race turns free in the same direction the drum will turn to haul-in wire

## ⚠ WARNING ⚠

Be certain the snap ring is seated in the groove in the splined bore of the inner race. This snap ring will keep the brake clutch assembly correctly positioned in the center of the friction brake pack. Binding of the brake or brake failure may occur if snap ring is omitted, which may cause winch failure resulting in property damage, injury, or death.

rope. An easy way to check the rotation is to hold the outer race in one hand and rotate the inner race. Install the brake clutch as shown in drawing on previous page.

8. Install a new O-ring on the motor pilot. Rotate the motor 180 degrees from its original position and install it onto the brake cylinder. Install and tighten motor capscrews to recommended torque.
9. Install new O-rings in the brake valve and manifold block. Attach the brake valve and manifold block to the motor using the original capscrews and tighten to recommended torque.
10. Connect the motor case drain hose to the motor case drain port.

**NOTE:** On two-speed motors, the case drain and shift drain should be connected directly to tank. DO NOT use the drain connection on the brake valve.

11. If your winch had the brake release hose connected directly to the motor, the original motor port must be plugged and the hose connected to the motor pressure port near the manifold block (lowering port).
12. Operate the winch slowly in both directions and check for oil leaks and/or unusual sounds from the hoist. The winch should operate smoothly in both directions. Refer to Wire Rope Installation section of this manual and properly install rope onto the hoist drum.
13. Before returning the hoist to full service, a light load should be lifted and held a few feet off the ground to be sure the static brake is functioning properly. The hoist should also be able to slowly lower the load in a smooth and controlled manner. If the hoist does not perform either of these functions, refer to Troubleshooting section of this manual for additional information.

---

## HOIST ASSEMBLY

---

1. Install the bearing support (Item 3) into the outboard endplate (Item 8). Rotate the bearing support so that the vent port will be located at the highest position based on the hoist installation to the machine. Install the eight capscrews and lockwashers (Item 1 and 2) and tighten to 160 lb-ft (217 N-m) torque.

**NOTE:** It may be easier to torque the fasteners after assembly has been completed.

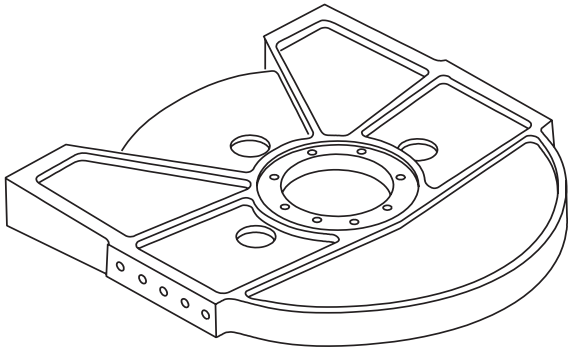

2. Place the drum support assembly on a clean work surface with the bearing support facing up. Lubricate the bearing and sealing surfaces on the bearing support. Install a new V-ring seal onto the bearing support.

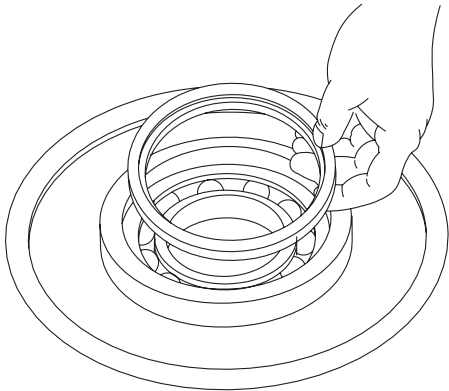

3. Install a new bearing in the drum if replacement is necessary, making certain to press it against the shoulder in the bottom of the bearing bore. Coat the outside diameter of a new seal with an aviation-gasket sealant. Turn the spring side of the seal toward the bearing, and press the seal into the seal bore, leaving it EVEN with the outer surface of the drum bore.
4. Turn the drum over, and set it down on the bearing support. Be careful not to damage the seal when lowering the drum onto the bearing support.

5. **-01 Drums:** Install the output planet carrier (400) into the drum while meshing the planet gears with the ring gear and the planet carrier with the drum bearing support.

**-02 Drums:** Lower the output planet carrier (400) into the drum, making certain the splines on the carrier mesh with the splines in the drum.

6. Install the output sun gear (12) in to the output planet carrier.

**-02 Drums:** Lower the ring gear into the drum while meshing the ring gear teeth with the planet gear teeth.

7. Apply general-purpose grease to thrust washer (13) and install it onto the pilot of the primary planet carrier (300). Turn the primary planet carrier over and install it into the ring gear while meshing the planet gears with the ring gear and the splines of the carrier with the output sun gear.

8. Install the primary sun gear (22) into the primary planet carrier. Apply general-purpose grease to thrust washer (15) and place it on top of the primary planet carrier. Center the thrust washer on the primary planet carrier

**-02 Drums:** Install the ring gear adapter (33) into the ring gear.

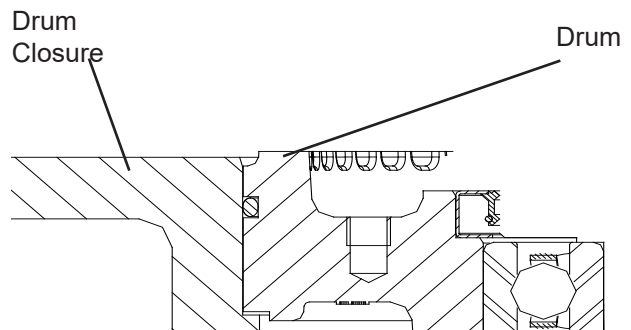

9. Install a new bearing (16) into the drum closure (23) if replacement is necessary. Make certain to press the bearing against the shoulder in the bearing bore. Coat the outside diameter of a new seal (18) with non-hardening aviation-gasket sealant.

**NOTE:** It is recommended to use an aviation-gasket sealant such as Loctite, Permatex, or similar store brands.

---

## HOIST ASSEMBLY

---

With the spring side toward the bearing, press the seal into the drum closure until the seal is even with the outer edge of the closure. Install a new O-ring (17) into the drum closure. Apply general-purpose grease to the outside diameter of the drum closure and install it into the drum. When properly installed, the outer edge of the drum closure will extend beyond the drum by approximately .034 inches (0.9 mm). If the drum closure cannot be installed as shown, one or more components may be out of position. The most common cause is the thrust washers are out of position or the output planet carrier is not seated. DO NOT proceed with assembly until the source of the problem has been identified and corrected.

10. Place the motor end plate onto the drum, aligning it approximately with the support end plate and centered on the drum. Install a new V-ring seal (20) onto the brake cylinder. Lubricate the seal and bearing surfaces of the brake cylinder, seal and bearing. Install the brake cylinder assembly into the drum and motor end plate in the same orientation as it was removed.
11. Install the eight capscrews and lockwashers (214 and 215) through the brake cylinder into the end plate. Loosely tighten all capscrews until just snug against the brake cylinder. Continue to tighten the capscrews in a criss-cross pattern one turn at a time until the motor end plate is drawn tightly up against the brake cylinder.
12. Install two tie plates (28) onto end plates using all 20 capscrews and lock washers (25 and 26). Be sure the curved sides of the tie plates are toward the top of the hoist. Evenly tighten all tie plate and brake cylinder/end plate capscrews to 80 lb.-ft (109 N-m) torque.
13. Install the overrunning brake clutch into the center of the brake pack. Refer to pages 25 and 26 for correct orientation of the clutch. The input (motor) side of the clutch is the end facing the motor with the longest spline engagement. It may be necessary to rotate the drum and hoist gear train slightly to align the splines of the shaft with the splines of the brake clutch. If the clutch does not align with the brake discs and input sun gear, install a hand-pump onto the brake release port and apply approximately 1000 PSI (6900 kPa) to fully release the spring applied brake and permit easy alignment of the brake components. The internal retaining ring in the clutch bore should be seated against the input sun gear when correctly installed.
14. Lubricate and install a new O-ring onto the hydraulic motor pilot. Engage the motor shaft with the inner race of the overrunning clutch and lower the motor into place. Install motor capscrews and lockwashers and torque to correct value.
15. Install all hydraulic lines disconnected during disassembly and route hoses to avoid chafing. Be careful to clean lines and fittings if there is a chance that paint chips or other contamination has entered the ports. Tighten all connections.
16. After the hoist assembly is complete, check all capscrews and hydraulic lines to make certain they have been properly installed and tightened correctly. Fill the hoist gear cavity to the center of the sight gauge or level plug. Refer to the Recommended Lubricant section of this manual.
17. Before returning the hoist to service, it should be tested on a hydraulic test stand that can operate the hoist to at least 35% of the rated flow, pressure and load. A moderate load should be lifted and held 3 ft. (1 m) off the ground to be sure the static brake is functioning properly. The hoist should be able to slowly lower the load in a smooth and controlled manner. If the hoist does not perform these functions correctly, refer to the Troubleshooting section of this manual.

**NOTE:** For CH175B hoists only-  
Prior to reassembly, inspect and replace the Speedi-Sleeve on the bearing support and brake cylinder. Speedi-Sleeves should require replacement only if damaged and no longer smooth in sealing area.

# BRAKE VALVE SERVICE

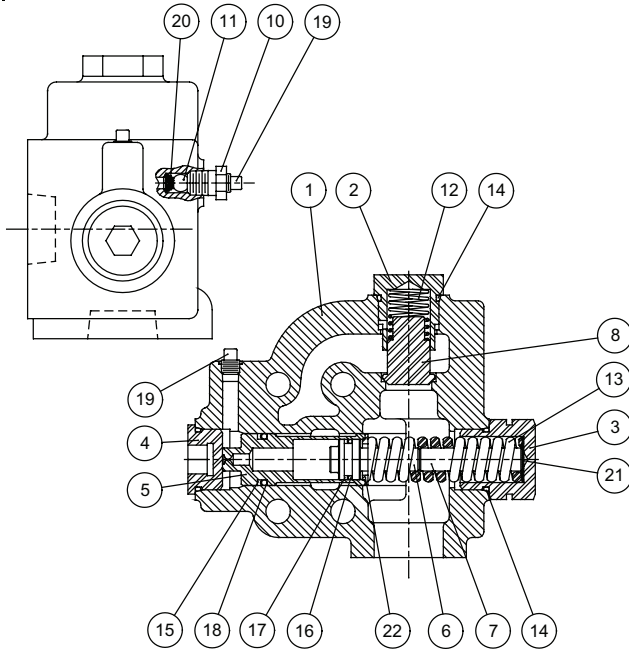

ITEM NO.	DESCRIPTION	QTY.	PART NO.
1	Valve Housing	1	NSS
2	Check Valve Retainer	1	24424
3	Spring Retainer	1	101016
4	Plug	1	24420
5	Main Piston	1	NSS
6	Damper Piston	1	NSS
7	Damper Piston Extension	1	101017
8	Check Valve Poppet	1	24423
10	Reducer	1	24436
11	Check Ball	1	24428
12	Check Valve Spring	1	24190
13	Main Piston Spring	1	24434
14	O-Ring	2	24186
15	Back-Up Ring	1	24778
16	O-Ring	1	24776
17	Back-Up Ring	1	24777
18	O-Ring	1	21123
19	Pipe Plug	2	18009
20	Check Spring	1	25373
21	Shim	1	25662
22	Spring Seat	1	101015

## DISASSEMBLY

Most CH Series hoists are supplied with our BRADEN 1-1/2 brake valve. It is a reliable hydraulic valve with internal components manufactured to close tolerances. Due to these close tolerances, several individual parts are not available as replacement parts and are noted in the following parts lists as NSS (not serviced separately).

Before disassembling the brake valve, be sure you have conducted all applicable troubleshooting operations and are certain the brake valve is causing the malfunction.

Thoroughly clean the outside surfaces of the valve and work in a clean dust-free area, as cleanliness is of utmost importance when servicing hydraulic components.

1-1/2 inch brake valves built after mid-March 1997 contain a spring seat (Item 22) between the spool spring and the spool. This provides a slightly larger, more uniform area for the spring to seat against the spool. The result is increased spring service life and improved repeatability of pressure/flow modulation over the full compression range of the spring.

The spring retainer has been modified to allow for the additional thickness of the spring seat and a groove machined into the hex end cap serves as a visual indication that the valve contains the new spring seat. The spring seat improvement may be added to earlier brake valves by installing kit, Part Number 62805. Items 3, 7, 13, 14 and 22 are included in the kit. We recommend that this kit be installed whenever the brake valve is removed for inspection or service.

It is always a good practice to check the initial opening or cracking pressure of the brake valve whenever the hoist is serviced or inspected. Refer to BRADEN Service Bulletin 527 for complete brake valve test and adjustment procedures.

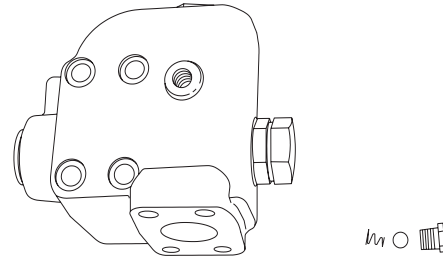

1. Remove the fitting, motor drain check ball and spring.

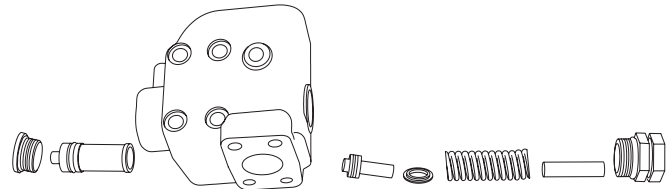

2. Remove the spool spring retainer and spool spring. Remove the spool plug and carefully remove the spool assembly. Remove the damper piston from the spool. The piston will come out of the spool slowly, because of a partial vacuum formed between the two. Use extreme care to avoid damaging the polished surfaces of either piece.

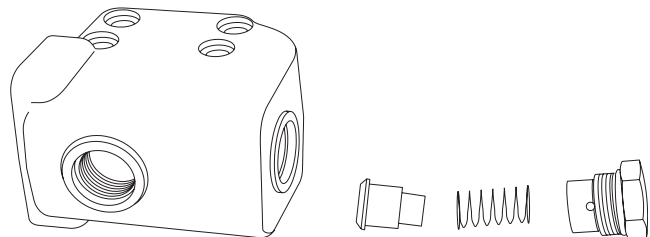

3. Remove the check valve spring retainer, spring and check valve poppet.

---

## BRAKE VALVE SERVICE

---

### CLEAN AND INSPECT

1. Discard all O-rings and back-up rings. Clean all parts in solvent and blow dry. Inspect polished surfaces of spool and damper piston for damage that may cause binding or leakage. Inspect spool bore in valve housing for damage or scoring. Inspect check valve seat in valve housing and check valve poppet. If the spools, bores or valves are damaged, the entire brake valve must be replaced. Check the free length of main piston spring. Replace if less than 3-7/16 in. (87.3 mm) long. Check the free length of the check valve spring. Replace if less than 1-1/2 in. (38.1 mm) long.

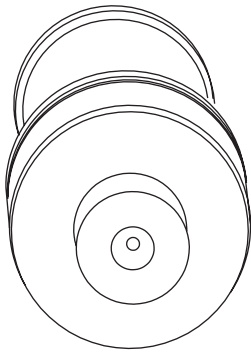

2. Inspect the 0.020-inch (0.5 mm) orifice in the end of the spool to be certain it is open.

### ASSEMBLY

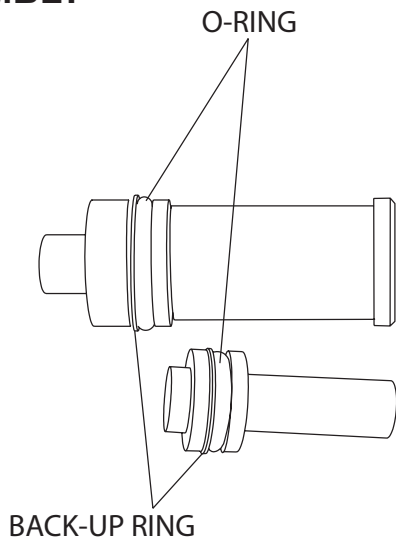

1. Install new O-rings and back-up rings on the spool and damper pistons as shown. It is important that each back-up ring is on the correct side of its O-ring. Take care not to cut the O-rings during assembly. Let the spool and piston set for 10 minutes before installing them into the brake valve housing. This allows O-rings to return to their original size after being stretched.
2. Install new O-rings on the plug and spool retainers.

3. Lubricate the spool and damper piston O-rings with hydraulic oil. Carefully install the damper piston into the spool. Carefully install the spool into the valve housing. Always install the spool into the valve body from the plug end, so the O-ring enters the bore first. Install the spring seat, spool spring, damper piston extension and spring retainer.

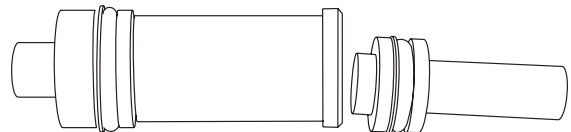

4. Install the check valve poppet, spring and check valve retainer.
5. Install the motor drain check ball, spring and fitting.
6. The brake valve is now completely assembled and ready to be installed on the hoist motor.



---

## BRAKE VALVE OPENING PRESSURE TEST

---

Whenever brake components are replaced or a brake component malfunctions or fails, the entire brake system should be inspected and tested. Your testing must include checking the brake valve opening pressure in addition to a thorough inspection of the failed components.

### Preparation

Begin the inspection by verifying that the brake valve and motor piping is correct for this application. If you are not certain, contact your nearest BRADEN distributor, the crane OEM, or the BRADEN factory Product Support Department before proceeding. Do not attempt repairs on equipment you are not familiar with. Fully remove the load from the hoist and block or secure any moveable parts of the crane or hoist before proceeding with brake valve test. It will be necessary to lower the hook block or ball to the ground (deck) since the brake will be completely released. Make certain the test area is clear of all unauthorized personnel as the hoist will be operated in raise and lower functions.

### Brake Valve Pressure Test

1. Shut off the engine or motor driving the hydraulic system and vent residual pressure as recommended by the crane OEM.
  2. Install an accurate 0-2000 PSI (0-13,800 kPa) pressure gauge teed into the brake release line, located at the lowering (non-brake valve) side of the hydraulic motor. This is typically a -4 JIC connection.
  3. To eliminate the slight drag effect of the internal multidisc brake, remove the brake release line from the hoist brake port and install a plug in the line or close to the needle valve if so equipped.
  4. To the internal brake port, install a hand pump with an accurate 0-2000 PSI (0-13,800 kPa) gauge. Operate the hand pump and apply approximately 1000 PSI (6,900 kPa) to the brake port to fully release the brake. Close the hand pump valve to hold the brake released during the remainder of the test.
  5. Operate the crane power source at full throttle and slowly move the winch control lever toward the lowering direction while monitoring the brake valve opening pressure. Record the pressure when the cable drum begins to turn in the lowering direction.
  6. The initial lowering pressure should be no lower than 575 PSI for the 1.5-inch BRADEN brake valve, Part Number 81609 which is used on most single-speed motors on CH165A and CH230B planetary hoists.
- If the initial lowering pressure is less than the specification listed the brake valve should be adjusted.

### ADJUSTMENT OF BRAKE VALVE

1. Inspect the main spool spring to make certain it is not damaged. If the spring is in good condition, the brake valve opening pressure should be adjusted by installing shims between the spring retainer, Item 3, and the main piston spring. A maximum of .062 in. (1.6 mm) shims are allowed in the 1.5 in. valves. Additional shims may result in accelerated spring failure due to over-compensation.
2. If the spring requires more than the maximum number of shims listed above to achieve the recommended opening pressure, the spring should be replaced.
3. Inspect the brake valve piston and damper piston for scoring and seal ring condition. The seal rings should be replaced following disassembly and inspection. If there is any scoring of the pistons and/or the brake valve housing, the entire brake valve must be replaced.
4. Inspect the check valve poppet and seat for irregular wear or damage. If the poppet set is damaged the entire brake valve must be replaced. Tighten the spring retainers to 40 lb-ft torque.

**NOTE:** Always recheck the brake operation following inspection or adjustment, prior to placing the hoist back in service.



**THIS PAGE INTENTIONALLY LEFT BLANK**

**THIS PAGE INTENTIONALLY LEFT BLANK**

# METRIC CONVERSION TABLE

## English to Metric

## Metric to English

### LINEAR

inches (in.)	X 25.4	= millimeters (mm)	millimeters (mm)	X 0.03937	= inches (in.)
feet (ft.)	X 0.3048	= meters (m)	meters (m)	X 3.281	= feet (ft.)
miles (mi.)	X 1.6093	= kilometers (km)	kilometers (km)	X 0.6214	= miles (mi.)

### AREA

inches <sup>2</sup> (sq.in.)	X 645.15	= millimeters <sup>2</sup> (mm <sup>2</sup> )	millimeters <sup>2</sup> (mm <sup>2</sup> )	X 0.000155	= inches <sup>2</sup> (sq.in.)
feet <sup>2</sup> (sq.ft.)	X 0.0929	= meters <sup>2</sup> (m <sup>2</sup> )	meters <sup>2</sup> (m <sup>2</sup> )	X 10.764	= feet <sup>2</sup> (sq.ft.)

### VOLUME

inches <sup>3</sup> (cu.in.)	X 0.01639	= liters (l)	liters (l)	X 61.024	= inches <sup>3</sup> (cu.in.)
quarts (qts.)	X 0.94635	= liters (l)	liters (l)	X 1.0567	= quarts (qts.)
gallons (gal.)	X 3.7854	= liters (l)	liters (l)	X 0.2642	= gallon (gal.)
inches <sup>3</sup> (cu.in.)	X 16.39	= centimeters <sup>3</sup> (cc)	centimeters <sup>3</sup> (cc)	X 0.06102	= inches <sup>3</sup> (cu.in.)
feet <sup>3</sup> (cu.ft.)	X 28.317	= liters (l)	liters (l)	X 0.03531	= feet <sup>3</sup> (cu.ft.)
feet <sup>3</sup> (cu.ft.)	X 0.02832	= meters <sup>3</sup> (m <sup>3</sup> )	meters <sup>3</sup> (m <sup>3</sup> )	X 35.315	= feet <sup>3</sup> (cu.ft.)
fluid ounce (fl.oz.)	X 29.57	= milliliters (ml)	milliliters (ml)	X 0.03381	= fluid ounce (fl.oz.)

### MASS

ounces (oz.)	X 28.35	= grams (g)	grams (g)	X 0.03527	= ounces (oz.)
pounds (lbs.)	X 0.4536	= kilograms (kg)	kilograms (kg)	X 2.2046	= pounds (lbs.)
tons (2000 lbs.)	X 907.18	= kilograms (kg)	kilograms (kg)	X 0.001102	= tons (2000 lbs.)
tons (2000 lbs.)	X 0.90718	= metric tons (t)	metric tons (t)	X 1.1023	= tons (2000 lbs.)
tons (long) (2240 lbs.)	X 1013.05	= kilograms (kg)	kilograms (kg)	X 0.000984	= tons (long) (2240 lbs.)

### PRESSURE

inches Hg (60°F)	X 3600	= kilopascals (kPa)	kilopascals (kPa)	X 0.2961	= inches Hg (60°F)
pounds/sq.in. (PSI)	X 6.895	= kilopascals (kPa)	kilopascals (kPa)	X 0.145	= pounds/sq.in. (PSI)
pounds/sq.in. (PSI)	X 0.0703	= kilograms/sq.cm. (kg/cm <sup>2</sup> )	kilograms/sq.cm. (kg/cm <sup>2</sup> )	X 14.22	= pounds/sq.in. (PSI)
pounds/sq.in. (PSI)	X 0.069	= bars	bars	X 14.5	= pounds/sq.in. (PSI)
inches H <sub>2</sub> O (60°F)	X 0.2488	= kilopascals (kPa)	kilopascals (kPa)	X 4.0193	= inches H <sub>2</sub> O (60°F)
bars	X 100	= kilopascals (kPa)	kilopascals (kPa)	X 0.01	= bars

### POWER

horsepower (hp)	X 0.746	= kilowatts (kW)	kilowatts (kW)	X 1.34	= horsepower (hp)
ft.-lbs./min.	X 0.0226	= watts (W)	watts (W)	X 44.25	= ft.-lbs./min.

### TORQUE

pound-inches (in.-lbs.)	X 0.11298	= newton-meters (N-m)	newton-meters (N-m)	X 8.851	= pound-inches (in.-lbs.)
pound-feet (ft.-lbs.)	X 1.3558	= newton-meters (N-m)	newton-meters (N-m)	X 0.7376	= pound-feet (ft.-lbs.)
pound-feet (ft.-lbs.)	X .1383	= kilograms/meter (kg-m)	kilogram/meter (kg-m)	X 7.233	= pound-feet (ft.-lbs.)

### VELOCITY

miles/hour (m/h)	X 0.11298	= kilometers/hour (km/hr)	kilometers/hour (km/hr)	X 0.6214	= miles/hour (m/h)
feet/second (ft./sec.)	X 0.3048	= meter/second (m/s)	meters/second (m/s)	X 3.281	= feet/second (ft./sec.)
feet/minute (ft./min.)	X 0.3048	= meter/minute (m/min)	meters/minute (m/min)	X 3.281	= feet/minute (ft./min.)

### TEMPERATURE

$$^{\circ}\text{Celsius} = 0.556 (^{\circ}\text{F} - 32)$$

$$^{\circ}\text{Fahrenheit} = (1.8^{\circ}\text{C}) + 32$$

### COMMON METRIC PREFIXES

mega	(M)	= 1,000,000 or 10 <sup>6</sup>	deci	(d)	= 0.1 or 10 <sup>-1</sup>
kilo	(k)	= 1,000 or 10 <sup>3</sup>	centi	(c)	= 0.01 or 10 <sup>-2</sup>
hecto	(h)	= 100 or 10 <sup>2</sup>	milli	(m)	= 0.001 or 10 <sup>-3</sup>
deka	(da)	= 10 or 10 <sup>1</sup>	micro	(μ)	= 0.000.001 or 10 <sup>-6</sup>

