

BRADEN[®]

CH640 PLANETARY HOIST

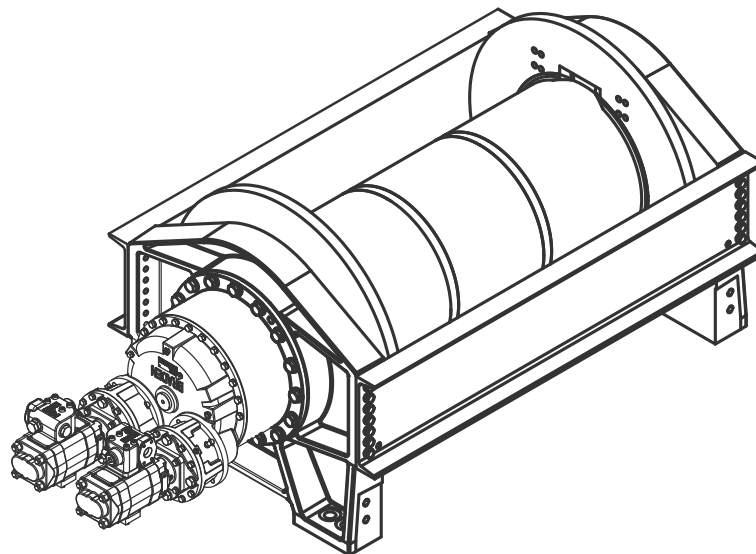

INSTALLATION, MAINTENANCE, AND SERVICE MANUAL

PACCAR WINCH

800 E. Dallas Street
Broken Arrow, OK 74012
www.paccarwinch.com

TABLE OF CONTENTS

FOREWORD	2
EXPLANATION OF MODEL NUMBER.....	2
GENERAL SAFETY RECOMMENDATIONS	3
THEORY OF OPERATION	4
WINCH AND WIRE ROPE INSTALLATION	5
RECOMMENDED FASTENER TORQUE.....	7
PREVENTIVE MAINTENANCE AND SPECIFICATIONS.....	7
RECOMMENDED GEAR OIL	8
MAJOR COMPONENT DISASSEMBLY	12
BRAKE SERVICE	15
SPRAG CLUTCH SERVICE	17
GEARBOX SERVICE.....	18
OUTPUT PLANET CARRIER SERVICE	19
PRIMARY PLANET CARRIER SERVICE	20
FIRST REDUCTION SPUR GEAR ASSEMBLY SERVICE	21
WINCH ASSEMBLY	22
HOSE AND FITTING DRAWINGS.....	24
TYPICAL WINCH EXPLODED VIEW	29
METRIC CONVERSION TABLE	31

FOREWORD

The following service instructions have been prepared to provide assembly, disassembly and maintenance information for the BRADEN Model CH series winch. It is suggested that before doing any work on these units, all assembly and disassembly instructions should be read and understood.

Some pictures in this manual may show details or attachments that are different from your winch. Also, some components have been removed for illustrative purposes.

Continuing product improvement may cause changes in your winch, which are not included in this manual. Whenever a question arises regarding your BRADEN Winch or this manual, please contact BRADEN Service Department for the latest available information.

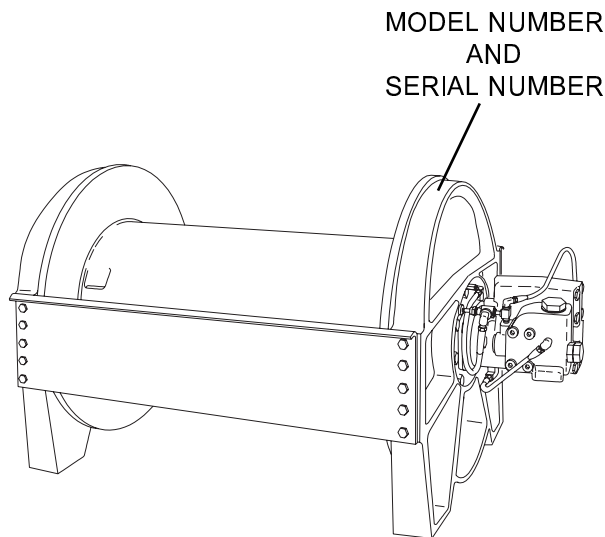

MODEL NUMBER AND SERIAL NUMBER

When information on a hoist is needed, always refer to the model number and serial number. Both are located on the top of the motor side end plate as indicated above.

EXPLANATION OF MODEL NUMBER

CH	640	A	-	102	D	108	01	P	-	1
CONSTRUCTION HOIST	MAX RATING	DESIGN MODEL		GEAR RATIO	DUAL MOTORS	MOTOR SIZE	DRUM SIZE	DRUM OPTION		OPTION

- CH** DESIGNATES CONSTRUCTION HOIST
- 640** DESIGNATES 64,000 LB MAXIMUM FIRST LAYER LINE PULL
- A** DESIGNATES THE MODEL SERIES RELATING TO DESIGN CHANGES
- 102** DESIGNATES TOTAL GEAR REDUCTION
- D** DESIGNATES DUAL MOTORS
- 108** DESIGNATES HYDRAULIC MOTOR DISPLACEMENT IN CU IN/REV (DECIMAL POINT ELIMINATED
EXAMPLE 108 -10.8 CU IN/REV)
- 01** DESIGNATES THE DRUM OPTION SIZE
- P** DESIGNATES OTHER DRUM OPTIONS (P = RATCHET AND PAWL)
- 1** PERMITS TESTING AND INSPECTION PER API2C FOR OFFSHORE CRANES

GENERAL SAFETY RECOMMENDATIONS

Safety Informational callouts used in this manual include:

WARNING

WARNING - This emblem is used to warn against hazards and unsafe practices which COULD result in severe personal injury or death if proper procedures are not followed.

Safety for operators and ground personnel is of prime concern. Always take the necessary precautions to ensure safety to others as well as yourself. To ensure safety, the prime mover and winch must be operated with care and concern by the operator for the equipment, and a thorough knowledge of the machine's performance capabilities. The following recommendations are offered as a general safety guide. Local rules and regulations will also apply.

WARNING

Failure to obey the following safety recommendations may result in property damage, personal injury or death.

1. Read all warning tag information and become familiar with all controls before operating hoist.
2. Never attempt to clean, oil or perform any maintenance on a machine with the engine running, unless instructed to do so in the service manual.
3. Never operate hoist controls unless you are properly seated at the operators station on the prime mover and you are sure personnel are clear of the work area.
4. Assure that personnel who are responsible for hand signals are clearly visible and that the signals to be used are thoroughly understood by everyone.
5. Ground personnel should stay in view of the prime mover operator and clear of hoist drum. Do not allow ground personnel near hoist line under tension. A safe distance of at least 1½ times the length of the cable should be maintained.
6. On machines having hydraulically, mechanically and/or cable controlled equipment, be certain the equipment is either lowered to the ground or blocked securely before servicing, adjusting and/or repairing the hoist. Always apply the prime mover parking brakes and lower equipment before dismounting the prime mover.
7. Inspect rigging, hoist and hydraulic hoses at the beginning of each work shift. Defects should be corrected immediately.
8. Keep equipment in good operating condition. Perform scheduled servicing and adjustments listed in the

CAUTION

CAUTION- This emblem is used to warn against potential or unsafe practices which COULD result in personal injury and property damage if proper procedures are not followed.

“Preventive Maintenance” section of this manual.

9. An equipment warm-up procedure is recommended for all start-ups and is essential at ambient temperatures below +40°F (4°C). Refer to “Warm-Up Procedure” listed in the “Preventive Maintenance” section of this manual.
10. Be sure of equipment stability before operating hoist.
11. The hoists described herein are neither designed nor intended for use or application to equipment used in the lifting or moving of persons.
12. Do not exceed the maximum pressure (PSI or kPa) or flow (GPM or LPM) stated in the hoist specifications.
13. Operate hoist line speeds to match job conditions.
14. Leather gloves should be used when handling hoist cable.
15. Never attempt to handle hoist cable when the hook end is not free.
16. When winding hoist cable on the hoist drum, never attempt to maintain tension by allowing hoist cable to slip through hands. Always use “hand-over-hand” technique.
17. Never use hoist cable with broken strands. Replace hoist cable.
18. Do not weld on any part of the hoist.
19. Do not use knots to secure or attach hoist cable.
20. Use recommended hydraulic oil and gear lubricant.
21. Keep hydraulic system clean and free from contamination at all times.
22. Use correct size cable anchor for cable and pocket in hoist drum.
23. The BRADEN wire rope anchors supplied with CH640 hoists **ARE NOT** capable of supporting the rated load. ALWAYS maintain a minimum of five (5) wraps of wire rope on the drum.

THEORY OF OPERATION

DESCRIPTION OF WINCH

The winch is made up of the following sub-assemblies and parts:

1. Hydraulic motor and brake valve
2. Brake clutch assembly
3. Multiple disc parking brake
4. External drive assembly
5. Motor end drum and drive support
6. Drum and drum support assembly
7. Tie plates

DUAL BRAKE SYSTEM

DESCRIPTION

The dual brake system consists of a dynamic brake system and a static brake system.

The dynamic brake system has two operating components:

1. Brake valve assembly
2. Hydraulic motor

The brake valve is basically a counterbalance valve. It contains a check valve to allow free flow of oil to the motor in the haul-in direction and a pilot operated, spring loaded spool valve that blocks the flow of oil out of the motor when the control valve is placed in neutral. When the control valve is placed in the pay-out position, the spool valve remains closed until sufficient pilot pressure is applied to the end of the spool to shift it against spring pressure and open a passage. After the spool valve cracks open, the pilot pressure becomes flow dependent and modulates the spool valve opening which controls the lowering speed.

The static brake system has three operating components:

1. Spring applied, hydraulically released multiple friction disc brake pack
2. Brake clutch assembly
3. Hydraulic piston and cylinder

The static brake is released by the brake valve pilot pressure at a pressure lower than that required to open the pilot operated spool valve. This sequence assures that when a load is slowed or stopped, dynamic braking takes place in the brake valve and little, if any, heat is absorbed by the friction brake.

The friction brake is a load holding brake only and has nothing to do with dynamic braking or rate of descent of a load. The inner race of the brake clutch is a splined coupling between the motor and the primary sun gear. The outer race is splined to the friction discs in the brake pack,

while steel separator plates are splined to the stationary housing. The brake clutch allows this shaft to turn freely in the haul-in direction, and locks up to force the brake discs to turn with the shaft in the pay-out direction.

Spring pressure prevents the brake discs from turning until the hydraulic cylinder and piston are pressurized, releasing the brake.

OPERATION

When hauling-in cable, or hoisting a load, the motor shaft and hoist drive gears turn freely as the sprag cams lay over between the inner and outer races of the brake clutch.

The multiple disc friction brake remains fully engaged and the winch is not affected by any braking action.

When the operation is stopped, the load tries to turn the winch drum, gear train and primary sun gear in the reverse direction. This reversed input to the inner race of the brake clutch causes the sprag cams to instantly roll upward and lock the shaft to the fully engaged friction brake.

When the winch is powered in the pay-out or lowering direction, the motor cannot rotate until sufficient pilot pressure is present to release the brake and open the brake valve. The friction brake will completely release at a pressure lower than that required to open the brake valve. The extent to which the brake valve opens determines the amount of oil that can flow through the motor, which is directly related to the drum speed of the winch. Increasing the flow of oil to the winch motor causes the pilot pressure to rise which increases the opening in the brake valve, allowing more oil to flow through the motor and increasing the drum speed. Decreasing this oil flow causes the pilot pressure to drop, reducing the opening in the brake valve which slows the motor and winch speed.

The friction brake receives very little, if any, wear in the pay-out or lowering operation. All of the heat generated by lowering and stopping a load is absorbed by the hydraulic oil where it can be readily dissipated.

When the control valve is shifted to neutral, pilot pressure drops closing the brake valve spool, stopping the motor and the load. The friction brake then engages and holds the load after the brake valve has closed.

When lowering a load very slowly for precise positioning, no oil flow actually occurs through the pilot operated spool in the brake valve. Pressure builds up to a point where the friction brake will release sufficiently to allow the load to rotate the motor through its own internal leakage. This feature results in a very slow speed and extremely accurate positioning.

WINCH OPERATION

The input section of the drive assembly is bolted to the motor end support and cannot rotate. The drive housing is the output member of the gear set and is bolted to the winch drum. The motor shaft is directly coupled to the primary sun gear through the inner race of the brake clutch. The motor turns the primary sun gear which drives three successive planetary gear sets, turning the drive housing and the winch drum.

In the haul-in direction, hydraulic oil flows through a large check valve in the brake valve and turns the motor in the

free rotating direction of the brake clutch, driving the gear train and winch drum. The friction brake remains fully engaged.

In the pay-out direction, oil flow through the motor is initially blocked by a spool in the brake valve. Oil pressure supplied to the motor through the control valve is piloted to the friction brake and the brake valve spool. The friction brake is released at a lower pressure than that required to shift the brake valve spool. When pressure is sufficient to shift the brake valve spool, oil is allowed to flow through the motor, rotating the winch gear train and drum.

WINCH INSTALLATION

WINCH AND WIRE ROPE INSTALLATION

1. The winch should be mounted with the centerline of the cable drum in a horizontal position. The mounting plane of the winch may be rotated in any position around this centerline. Any vent in the drive assembly must be above the centerline of the cable drum, and as close to top dead center as possible. If the drive assembly is equipped with an oil level indicator, it may also have to be moved.

2. When mounting the winch, use all eight (8) mounting holes and grade eight (8) bolts and nuts. Evenly tighten the nuts to the torque in the "Recommended Fastener Torque" chart. Make certain the winch drum is centered behind the first sheave and the fleet angle does not exceed 1½ degrees. The winch should also be mounted perpendicular to an imaginary line from the center of the drum to the first sheave to ensure even spooling.

Refer to "Dimensional Drawing" for bolt hole size and pattern.

It is important that the winch is mounted on a surface that will not flex when the winch is in use, and cause binding of the gear train. Binding in the gear train will result in accelerated wear and excessive heat. Also, the mounting surface should be flat with +/- 0.020 inches. If necessary, install shims under the winch mounting pads to achieve even mounting.

3. The hydraulic lines and components that operate the winch should be of sufficient size to assure minimum back pressure at the winch. The back pressure at the motor must not exceed 100 psi (690 kPa) to maintain full brake system design factor and optimum motor seal life.

The winch directional control valve must be a three position four way valve with a motor spool such that when the valve is in the center position both work ports are open to tank (open center, open port).

4. High quality hydraulic oil is essential for satisfactory performance and long hydraulic system component life.

Oil have 150 to 330 SUS viscosity at 100°F (38° C) and viscosity index of 100 or greater will give good results under normal temperature conditions. The use of an oil having a high viscosity index will minimize cold start trouble and reduce the length of warm-up periods. A high viscosity index will minimize changes in viscosity with corresponding changes in temperature.

Maximum cold weather start-up viscosity should not exceed 5,000 SUS with a pour point at least 20°F (11° C) lower than the minimum ambient temperature.

Under continuous operating conditions the temperature of the oil at any point in the system must not exceed 180° F (82° C). 120° F (49° C) to 140° F (60° C) is generally considered optimum.

In general terms:

for continuous operation at ambient temperatures between 50° F (10° C) and 110°F (43°C) use SAE 20W; for continuous operation between 10° F (-12° C) and 90°F (32° C) use SAE 10W; for applications colder than 10°F (-12° C), contact the BRADEN/GEARMATIC Service Department. The use of multi-viscosity oils is generally not recommended.

For winch gear oil, refer to "Lubricant Specifications" in the "Preventive Maintenance and Specifications" section.

5. The hydraulic oil filter should have a 10 micron nominal rating and be full flow type.

6. The vent plug in the motor adapter must be located as close to top dead center as possible. If the winch is mounted on a pivoting surface, the vent plug must remain above the centerline of the cable drum to prevent gear oil leakage.

7. Refer to "Dimensional Drawing" for relationship between drum rotation and which port is pressurized.

WIRE ROPE INSTALLATION

The CH640 hoist is supplied with a 3 piece cable anchor and a cable clamp. Either method can be used to anchor wire rope to the drum.

⚠ WARNING ⚠

THE CABLE ANCHORS ALONE ON HOISTS ARE NOT DESIGNED TO HOLD RATED LOADS. Loads applied directly to the wire rope anchor may cause the wire rope to pull free and result in the sudden loss of load control and cause property damage, personal injury or death. A minimum of 5 wraps of wire rope must be left on the drum barrel to achieve rated load.

The wedge and anchor pocket must be clean and dry. The end of the wire rope being anchored to the drum must be clean and dry and not frayed. Anything on the end of the wire rope to keep it from fraying (i.e. tape or wire) must not be in contact with the wedge when the installation is complete. Consult the wire rope manufacturer on the proper treatment of the dead end of the wire rope. Some rope manufacturers recommend when using rotation resistant wire rope, that the rope end be seized, welded or brazed before inserting the wire rope into the wedge socket to prevent core slippage or loss of rope lay.

3 Piece Cable Anchor Installation

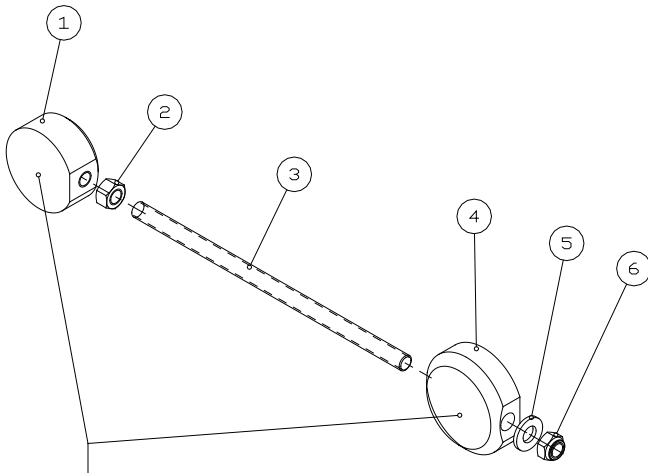

These surfaces face toward drum flange when installed.

Install threaded rod (Item 3) into Item 1 until it bottoms, then tighten jam nut (Item 2) against Item 1.

Feed cable through opening in drum flange until it extends outside cable pocket 2 to 4 inches.

Insert partially assembled anchor (Items 1, 2, 3) into the cable pocket with flat side of Item 1 against the drum flange. The anchor will wedge between the cable and the top of the cable pocket.

Working from the other end of the cable pocket, install Item 4 onto the threaded rod. Be sure to place the flat side of Item 4 against the drum flange, then install the rounded end onto the threaded rod first so the washer (Item 5) and locknut (Item 6) will seat against the flat end.

Install the washer and locknut onto the threaded rod and tighten securely to 45 ft-lbs. (This is the torque value of the 1/2-13 stainless-steel rod).

Apply a light load of 1,000 to 2,000 pounds on the cable and carefully spool it onto the drum. Retighten the nut again to 45 ft-lbs. As previously stated in the warning, the cable anchor is not designed to hold the rated load of the hoist. **DO NOT** apply full rated load until five or more wraps of cable are on the drum.

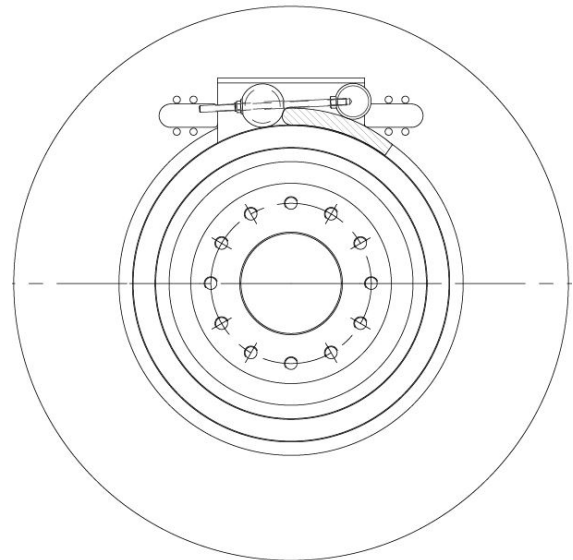

3-piece cable anchor properly installed
(viewed from outside drum flange)

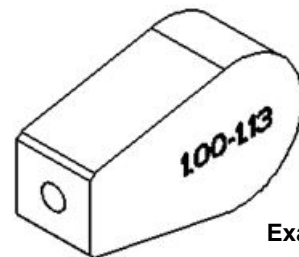

Example

NOTE: Confirm that the cable clamp assembly is suitable for your rope size by reading the size range (in inches) stamped on part itself.

Cable Clamp Installation

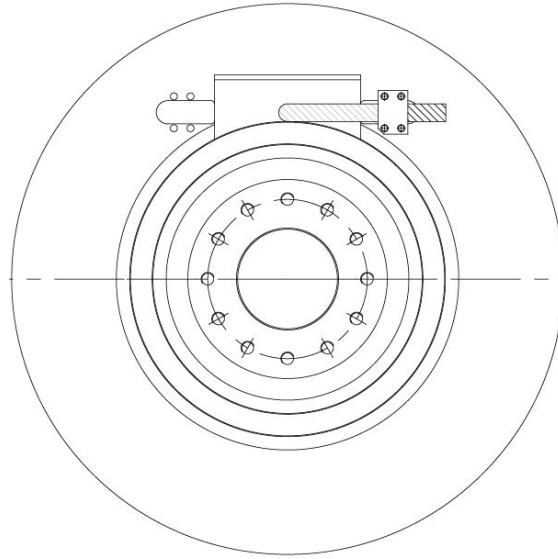

Cable clamp properly installed
(viewed from outside drum flange)

WIRE ROPE INSTALLATION

Remove both sheet metal covers from the end bracket of the hoist. Pull the end of the cable through the opening in the drum flange and out through the end bracket as shown in Figure 1. Form the cable around part 1 of the wedge as shown in Figure 2, and pull the assembly into the anchor pocket (part 2 and the nut are not attached to part 1 at this time). Access the threaded rod attached to part 1 through the other opening in the end bracket and install part 2 and the nut. On large diameter cable, it may be necessary to hammer on the cable looped around part 1 to force it far enough into the anchor pocket to attach part 2.

It is important for the dead end of the cable to extend beyond the end of part 2, as shown in Figure 2, but not far enough to come in contact with the end bracket when hoist is operating. A load should be applied to the live end of the cable to properly seat the anchor. After initial load is applied, tighten nut holding part 2 in place to 11 ft-lbs. A minimum of five wraps of wire rope should remain on the cable drum at all times. Refer to General Safety Recommendations section of this manual for additional information.

Figure 1

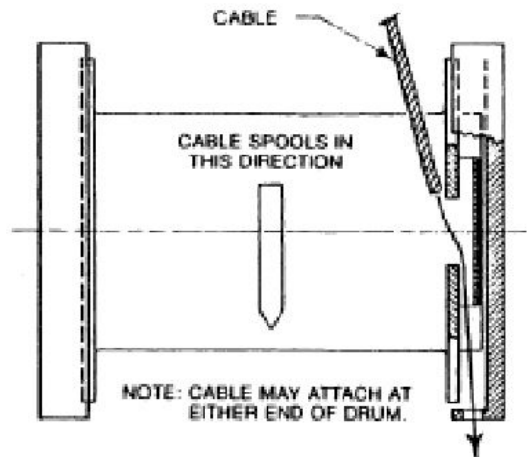
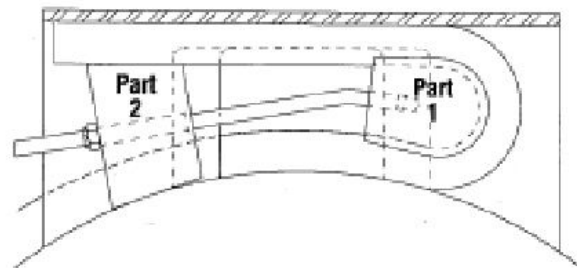

Figure 2



Feed cable through opening in drum flange until it is approximately one inch past the machined pocket in the flange. Install cable clamp as shown and fasten it to the drum flange with the four capscrews provided. Tighten all four bolts to 39-ft-lbs. (See drawing of cable clamp installation; bolts are located in upper right corner.)

Apply light load of 1,000 to 2,000 pounds on the cable and carefully spool it onto the drum. Retighten the bolts again to 39 ft-lbs. As previously stated in the warning at the beginning of this section, the cable anchor is not designed to hold the rated load of the hoist. Do not apply full rated load until five or more wraps of cable are on the drum.

RECOMMENDED FASTENER TORQUE

Bolt Diam. Inches	Thread per inch	Torque LB-FT (N.m)			
		Grade 5		Grade 8	
		Dry	Lubed	Dry	Lubed
1/4	20	8	6	12	9
	28	(11)	(8)	(16)	(12)
5/16	18	17	13	24	18
	24	(23)	(17)	(33)	(24)
3/8	16	31	23	45	35
	24	(42)	(31)	(61)	(47)
7/16	14	50	35	70	50
	20	(68)	(47)	(95)	(68)
1/2	13	75	55	110	80
	20	(102)	(75)	(149)	(108)
9/16	12	110	80	150	110
	18	(149)	(108)	(203)	(149)
5/8	11	150	115	210	160
	18	(203)	(156)	(285)	(217)

Bolt Diam. Inches	Thread per inch	Torque LB-FT (N.m)			
		Grade 5		Grade 8	
		Dry	Lubed	Dry	Lubed
3/4	10	265	200	380	280
	16	(359)	(271)	(515)	(380)
7/8	9	420	325	600	450
	14	(569)	(441)	(813)	(610)
1	8	640	485	910	680
	14	(868)	(658)	(1234)	(922)
1 1/8	7	790	590	1290	970
	12	(1071)	(800)	(1749)	(1315)
1 1/4	7	1120	835	1820	1360
	12	(1518)	(1132)	(2468)	(1817)
1 3/8	6	1460	1095	2385	1790
	12	(1979)	(1485)	(3234)	(2427)
1 1/2	6	1940	1460	3160	2370
	12	(2360)	(1979)	(4284)	(3214)

To convert LB-FT to Kg-m, multiply LB-FT value by 0.1383

8-2008

PREVENTIVE MAINTENANCE AND SPECIFICATIONS

Initially, gear oil should be changed after the first 100 hours of operation. At intervals of 1,000 hours or every six months, grease drum support at grease fitting using an NLGI #2 lithium-complex base extreme-pressure grease that meets or exceeds NLGI GC or GC/LP specifications.

1. Vent Plug

The vent plug is located directly above winch motor near the break release port. It is important to keep vent clean and unobstructed. When changing gear oil, remove vent plug, clean in solvent, and reinstall. Do not paint over vent or replace with a solid plug.

2. Hydraulic System

Replace the original filter element after the first 50 hours of operation, then every 500 operating hours or 3 months according to equipment manufacturer's recommendations.

3. Wire Rope

Inspect entire length of wire rope according to wire rope manufacturer's recommendations.

4. Mounting Bolts

Tighten all winch base mounting bolts to the recommended torque after the first 100 hours of

operation, then every 1,000 hours or six months, whichever occurs first.

5. Warm-up Procedures

A warm-up procedure is recommended at each start-up and is essential at ambient temperatures below 40 degrees F. (4 degrees C.).

The prime mover should be run at its lowest recommended RPM with the hydraulic winch control valve in neutral, allowing sufficient time to warm up the system. Operate winch several times at low speeds (forward and reverse) to prime lines with warm hydraulic oil and to circulate gear lubricant through planetary gear sets.

6. Recommended Planetary Gear Oil

Field experience, supported by engineering tests, indicates the use of proper planetary gear oil is essential to reliable and safe operation of the brake, obtaining long gear train life. Refer to Recommended Gear Oil later in this section.

For simplicity, BRADEN has listed one readily available product in each temperature range which has been tested and found to meet our specifications. This is not to say that other lubricant brands would not perform equally as well.

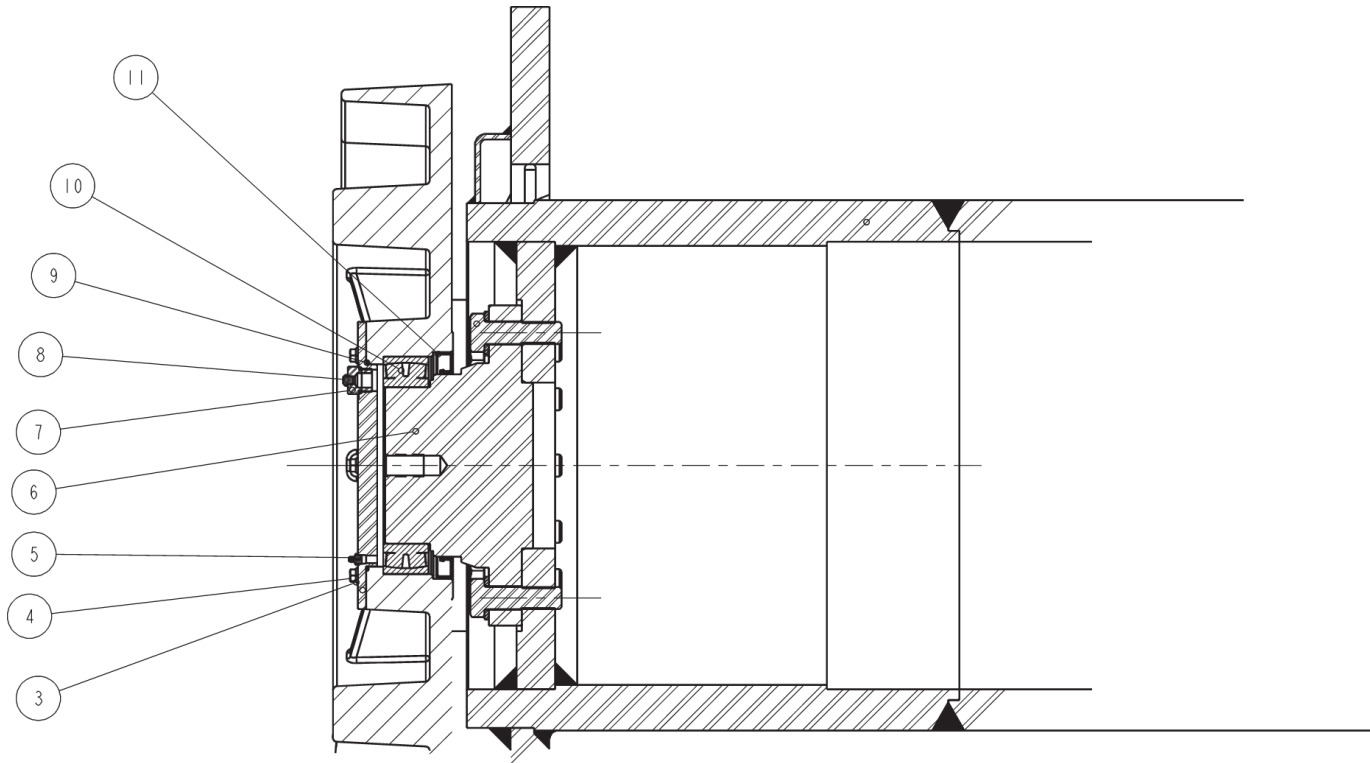

Grease Bearing Support

7. Grease Drum Support

Remove plug (Item 7).

Pump grease into grease zerker (Item 5) until new grease comes out, then reinstall plug.

Grease drum support at grease fitting using an NLGI #2 lithium-complex base extreme-pressure grease that meets or exceeds NLGI GC or GC/LP specifications.

NOTE: Grease

Every 1,000 hours or six months, grease drum support at grease fitting using an NLGI #2 Lithium complex base extreme-pressure (EP) grease that meets or exceeds NLGI GC or GC/LP specifications.

! WARNING !

Failure to properly warm up the winch, particularly under low ambient temperature conditions, may result in temporary brake slippage due to high back pressures attempting to release the brake, which could result in property damage, severe personal injury or death.

If the following lubricant brands are not available in your area, make certain your lubricant vendor supplies you with oil that is equivalent to those products listed below.

CH640 planetary winches are factory filled with Texaco Meropa 150 or equivalent.

The gear oil should be changed whenever the ambient temperature changes significantly and an oil from a different temperature range would be more appropriate.

! WARNING !

Failure to use the proper type and viscosity of planetary gear oil may contribute to intermittent brake clutch slippage which could result in property damage, severe personal injury or death. Some gear lubricants contain large amounts of EP (extreme pressure) and anti-friction additives which may contribute to brake slippage and damage to brake friction discs or seals. Oil viscosity with regard to ambient temperature is also critical to reliable brake operation. Our tests indicate that excessively heavy or thick gear oil may contribute to intermittent brake slippage. Make certain that the gear oil viscosity used in your winch is correct for your prevailing ambient temperature.

RECOMMENDED PLANETARY GEAR OIL

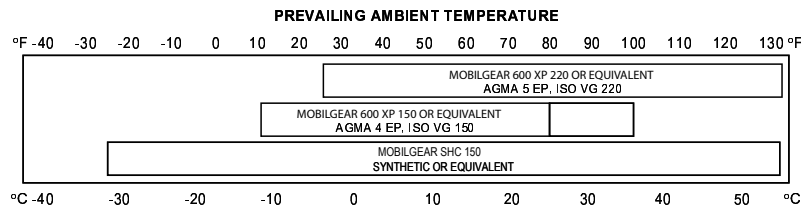

i NOTE: SHADED TEMPERATURE RANGE IN THE CHART ABOVE NOT RECOMMENDED FOR SEVERE APPLICATIONS SUCH AS: OFFSHORE CRANES, SUSTAINED FAST DUTY CYCLES OR FREQUENT LIFTING.

Planetary hoists are factory filled with Mobilgear 600 XP 150, or equivalent. Consult your oil supplier for other equivalent oils if required.

Mobil	Shell	Chevron	Texaco
Mobilgear 600 XP 150	Omala 150	Gear Compounds EP 150	Meropa 150
Mobilgear 600 XP 220	Omala 220	Gear Compounds EP 220	Meropa 220

Oil Capacities

Gearbox

Units with single motor input..... 42 pints (19.9 L)
 Units with dual motor input..... 48 pints (22.7 L)

i NOTE: Oil capacities are approximate. With the winch drum in a horizontal position, oil level should be at the centerline of the gearbox.

On some CH640 hoists, pipe plug sight gages are installed in two ports on the input housing to the right of the motor. These function as high and low level gages. The high level should have no oil and the low level should be full. The midline of the gearbox oil level is 42 pints and 42 pints should be added to an empty gearbox. If the oil level drops into the bottom sight gage the volume in the gearbox is 34 pints which is a safe volume, but 8 pints should be added to bring the level to normal and fill the low level sight gage.

Winch drums contain the following quantity of gear oil as a rust preventative

01 Drum..... 8 pints (3.8 L)
 02 Drum..... 12 pints (5.7 L)
 21, 22 & 23 Drums..... 14 pints (6.6 L)

Torque Values

Drum bearing supports to drum..... 600 lb-ft (814 N-m) - Apply Loctite 242 to clean dry threads
 Gearbox to sideplate..... 600 lb-ft (814 N-m) - Clean dry threads

Drum Dimensions (Barrel Diameter X Flange Diameter X Drum Length)

01..... 24 in. (610 mm) X 41.5 in. (1,054 mm) X 36.13 in. (918 mm)
 02..... 24 in. (610 mm) X 41.5 in. (1,054 mm) X 54.13 in. (1,375 mm)
 21..... 24 in. (610 mm) X 41.5 in. (1,054 mm) X 66 in. (1,676 mm)
 22..... 22 in. (559 mm) X 41.5 in. (1,054 mm) X 72 in. (1,829 mm)
 23..... 24 in. (610 mm) X 41.5 in. (1,054 mm) X 72 in. (1,829 mm)

**Braden recommends the following Inspection, Testing and Preventive Maintenance procedures.
For additional details, refer to Braden publication PB-308.**

Inspection, testing and preventive maintenance requirements are divided into several categories: Pre-use, Quarterly, Semiannual and Annual as outlined below. The Installation, Maintenance and Service Manual for each model provides specific instructions for maintenance and service.

Some inspection intervals make reference to hoists used in "Severe Duty Applications". Severe Duty Applications are where the hoist is operated more than 12 hours per day and/or for extended periods of time at or near the rated capacity of the hoist.

Anytime that the hoist exhibits erratic operation and/or unusual noise(s), the hoist should be taken out of service until it is inspected and serviced by a qualified technician.

REGULAR INSPECTION, TESTING & PREVENTIVE MAINTENANCE - Must include, but not be limited to the following:

PRE-USE INSPECTION (each shift the hoist is used): Will be performed prior to placing the crane into service and then as necessary during the day for extended operation.

1. Check for external oil leaks and repair as necessary. **This is extremely important due to the accelerated wear that can be caused by insufficient lubricating oil in the hoist.** Lubricant level must be maintained between the maximum and minimum levels. Use only the recommended type of lubricant; see service manual for details. On models without a sight glass, check oil level monthly.
2. Check the ratchet and pawl mechanism (if so equipped) for proper operation and for full engagement of the pawl with the ratchet wheel. Repair and/or adjust as necessary.
3. Check hydraulic plumbing for damage, such as chafed or deteriorated hoses, and repair as necessary.
4. Visually inspect for loose or missing bolts, pins, keepers or cotter pins and replace or tighten as necessary.

QUARTERLY INSPECTION (every 3 months) or monthly in Severe Duty Applications or prior to putting the machine into service if it has not been used for 3 months or more. Documentation of the inspections must be kept with the hoist/crane for a minimum of two (2) years from the date of the inspection (see page 3).

Perform the PRE-USE INSPECTION plus the following:

1. Check the lubricant level in the hoist(s) and maintain it between maximum and minimum levels. Use only recommended type of lubricant; see service manual for details.
2. On hoists used for personnel handling, the internal spring-applied brake shall be tested in accordance with the procedure on page 5 of publication PB-308.
3. Inspect for corrosion of fasteners, mounting base, drum, etc. and repair/replace as necessary.

SEMI-ANNUAL INSPECTION (every 6 months), or quarterly in Severe Duty Applications. Documentation of the inspections must be kept with the hoist/crane for a minimum of two (2) years from the date of the inspection (see next page).

Perform the **PRE-USE INSPECTION** and **QUARTERLY INSPECTION** plus the following:

Take a sample of the lubricating oil from the hoist drum, following the oil sampling procedure on page 4 of publication PB-308, and analyze it for wear metals content, the correct viscosity, signs of overheating, water and other contaminants. If the oil sample contains an unusual amount of metallic particles, the hoist should be taken out of service and undergo a tear down inspection. The oil sample must be taken prior to changing the lubricating oil. The Semi-annual oil analysis can be omitted if the crane has been used less than 250 hours since the previous oil sample.

ANNUAL INSPECTION, Testing & Preventive Maintenance or Semi-annually in Severe Duty Applications. Documentation of the inspections must be kept with the hoist/crane for a minimum of two (2) years from the date of the inspection (see next page). The Annual Inspection must include, but not be limited to the following:

1. Perform the **PRE-USE INSPECTION, QUARTERLY** and **SEMIANNUAL INSPECTIONS**, plus the following:
2. Change lubricating oil in hoist drum or gearbox after oil sample is taken. Refer to Recommended Gear Oil, earlier in this section. Failure to follow these recommendations may result in brake failure.

NOTE:If the oil sampling/analysis has not been performed as required, refer to the tear down inspection section below.

The user of BRADEN products is responsible for hoist inspection, testing and maintenance noted above with frequency dependent upon the severity of the hoist duty cycle and the thoroughness of the preventive maintenance program in effect.

Alternate inspection periods may be used if approved in writing by BRADEN. Those that are interested in an alternate inspection period should submit a written proposal to BRADEN that includes typical duty cycle for the hoist along with a detailed description of the preventive maintenance program for these hoists.

Inspection Records & Retention

Crane inspection reports as well as records of preventive maintenance, repairs and modifications to hoists should be available and accessible for a minimum of two years. These records should include, but not be limited to, hoist model and serial number, name and employer of repair/inspection technician, date and description of preventive maintenance, functional test reports and repairs.

To provide customers with qualified outlets for hoist service and repairs, BRADEN has established authorized Service Centers. These Service Centers have factory trained service technicians, up-to-date service information, extensive parts inventories, complete testing facilities, and are audited by BRADEN on a regular basis for compliance. **BRADEN strongly recommends the use of BRADEN authorized Service Centers** for maintenance, repair and inspection of BRADEN/Gearmatic products. Contact the Braden Product Support Department at 918-251-8511 for the names of current authorized Service Centers.

TEAR DOWN INSPECTION – Any Hoist that has NOT been subject to regular oil sample analysis should undergo a tear down inspection on an annual (12 month) basis. Also, if a hoist has an unknown history of repair and/or maintenance, it is recommended that the hoist undergo a tear down inspection prior to it being placed into service.

A tear down inspection should include the hoist being completely disassembled, cleaned and inspected and replacement of all worn, cracked, corroded or distorted parts such as pins, bearings, shafts, gears, brake rotors, brake plates, drum and base. Refer to the applicable BRADEN or Gearmatic Service Manual for more details. All seals and o-rings should be replaced during a tear down inspection.

Any deficiencies, such as those listed above shall be corrected immediately.

All of the following operations must be performed before the hoist is placed back in service:

The rebuilt hoist must be line pull tested to the rated load of the hoist (hoist rating will vary with motor, gear ratio and drum options) with a dynamometer or equivalent measuring device. This test load should be the maximum rating for the hoist for the specific application (at the normal hydraulic relief valve setting for the hoist), not the reduced rating for personnel lifting.

The hoist must be dynamically tested by rotating the drum several times, in both the hoisting and lowering directions, while under a load of at least 30% of the hoist lifting capacity. Check for smooth operation during this procedure.

The brake should be tested per the brake test procedures on page 5 of Publication PB-308.

After inspection or rebuild and testing, a new certificate for personnel handling will be issued by the inspector/ service technician effective on the date the hoist is placed back in service.

(See sample inspection certificate on next page)

Name of Service Company	
Approved by BRADEN for handling personnel if used and maintained in accordance with BRADEN Recommendations For Personnel Handling Hoists	
Hoist Model No.:	_____
Hoist Serial No.:	_____
Date of Inspection:	_____
Work Order/Job No.:	_____
Inspector's Name:	_____
For a copy of recommendations call or write: BRADEN PO Box 547, Broken Arrow, OK, 74012, USA (918) 251-8511	

Sample inspection certificate

PERSONNEL HANDLING

BRADEN recognizes that most hoists and cranes are designed and intended for handling materials and not personnel. **The crane or hoist is only to be used to handle personnel if it can be shown there is no less hazardous way of carrying out the job.** In these situations, all safety precautions must be strictly adhered to. BRADEN recommends adherence to the latest revision of API 2D (RP 2D) and/or ANSI/ASME standard B30.5 and/or OSHA and/or other applicable standards for your application. It is important that you obtain a copy of all applicable safety standards, and that you read and understand them prior to using the hoist. **In addition to**, or in conjunction with, the applicable standards, BRADEN requires:

- The hoist must be maintained in accordance with the recommendations in this document and the service procedures in the Installation, Maintenance and Service Manual for your specific hoist.
- When handling personnel, the allowable line pull will be limited to 30% of the hoist rated line pull. This reduction increases the hoist design factor from 3:1 to 10:1, approximately. Example: a hoist rated at 15,000 lbs. on the first layer will be rated at $15,000 \times 0.3 = 4,500$ lbs. on the first layer when handling personnel.
- Personnel are only permitted to ride in an approved personnel platform as described in API, OSHA or ANSI/ASME standards.
- The crane must be in good working order and equipped with all required safety equipment, including an anti two-blocking device or warning signal and a boom angle and length indicator. Two-blocking occurs when the load block or hook assembly comes in contact with the upper block or point sheave assembly and often results in damage to the wire rope, rigging and/or hoist.
- Personnel being lifted or supported shall wear safety belts with lanyards attached to designated points unless lifting over water. If lifting over water, provide approved personal flotation devices (PFD's).
- The lifting and supporting shall be made under controlled conditions and under the direction of an appointed signal person.
- The operator and signal person shall conduct a test lift, without personnel in the personnel platform, to verify adequacy of the crane footing or support. The crane outriggers, if so equipped, must be fully extended and properly set.
- Cranes shall not travel (move locations) while personnel are on the personnel platform.
- The platform must be landed or tied off, and all brakes set before personnel enters or exits.

MAJOR COMPONENT DISASSEMBLY

Gearbox Removal

Remove all cable from the drum. Drain oil from the gearbox using the drain plug(s) on the brake housing(s). Remove one of the 1/2 inch plugs in the gear housing as an air vent. Block the hoist up so it is resting on the barrel of the cable drum. Be sure to secure the hoist so it cannot roll. Removing the hydraulic motor(s) at this time will reduce the weight of the gearbox assembly and improve balance, although it is not required.

Three rods should be used to assist in the removal of the gearbox. These can be made from studs, bar stock, or long capscrews, as shown below.

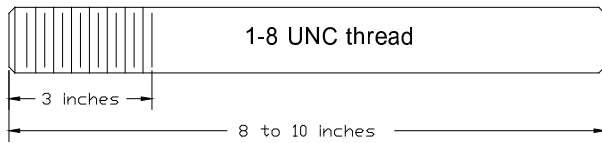

Remove the top three 1" capscrews from the ring gear to sideplate joint. Insert 3 rods into the threaded holes in the sideplate.

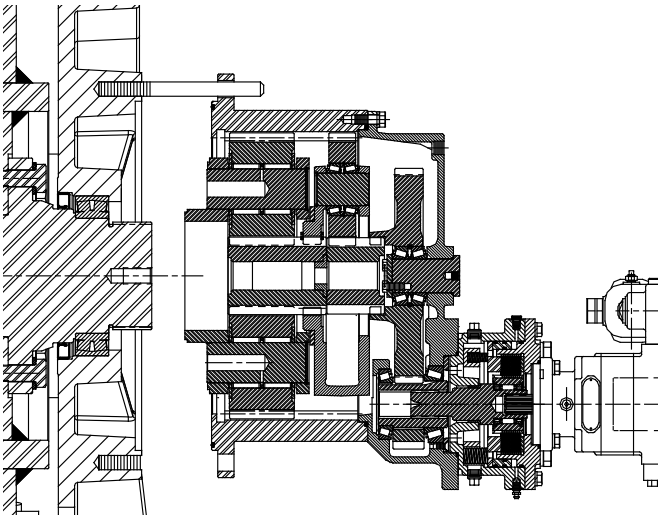

CAUTION

The gearbox weighs approximately 1,400 pounds (635 kg). Be sure lifting equipment has adequate capacity.

Support the gearbox and remove the remaining capscrews from the ring gear flange. Separate the ring gear from the side plate and slowly slide the gearbox away from the sideplate.

Keep the output carrier firmly against the primary carrier, as shown above, so the thrust washer between the carriers does not fall out of place.

Once the output carrier spline is free from the drum drive shaft, set the gearbox assembly down.

CAUTION

Each side plate weighs approximately 1,000 pounds (454 kg). Be sure lifting equipment has adequate capacity.

Sideplates & Drum

Motor End Disassembly

A simple fixture is required to disassemble and reassemble the sideplates to the drum support shaft and drum drive shaft. The motor end fixture is shown below.

Assemble the fixture as shown below. Slowly and evenly tighten the two 3/4 inch capscrews to disassemble the sideplate from the drum drive shaft. The bearing and seal can now be inspected and serviced as required.

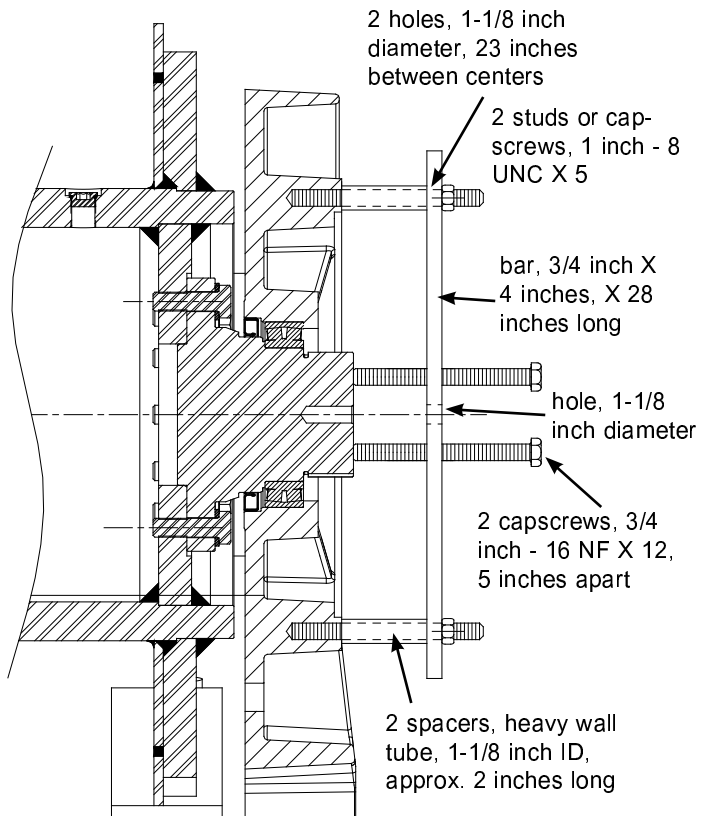

Motor End - Disassembly

Support End Disassembly

The fixture to disassemble and reassemble the sideplate to the drum support shaft is shown below.

Assemble the fixture as shown below. Slowly and evenly tighten the two 3/4 inch capscrews to disassemble the sideplate from the drum support shaft. The bearing and seal can now be inspected and serviced as required.

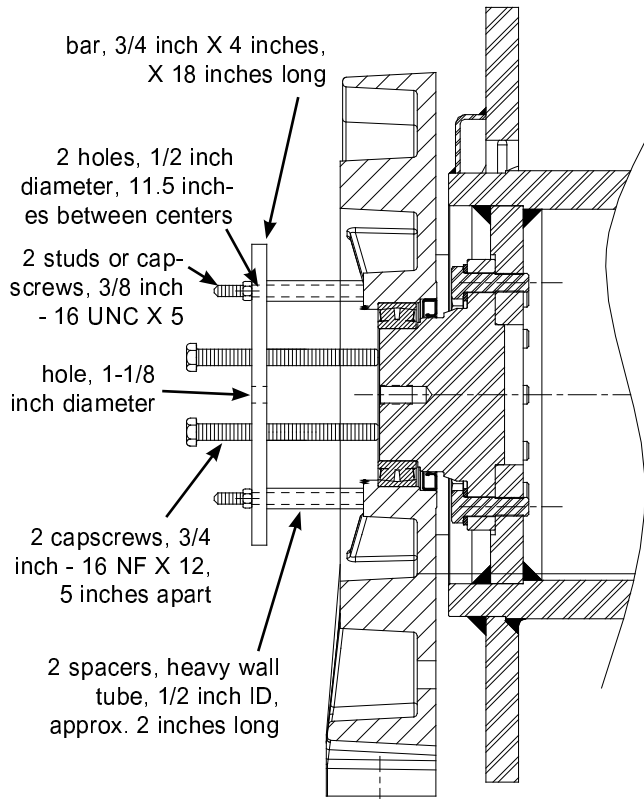

Support End - Disassembly

Assembly

Assembly procedure for either end of the winch will be the same. Drawings are shown for both the motor end and support end.

Assemble the fixture as shown in the appropriate drawing. Be sure all bearing and sealing surfaces are clean and dry. Apply a light coat of grease to the lip seal in the sideplate. Install a 1 inch - 8 UNC stud, washer and nut into the drum drive shaft or support shaft, as shown. Slowly tighten the nut to pull the shaft into the end sideplate. Be sure the two pieces are being drawn together in proper alignment to avoid damaging the seal or binding the bearing. When correctly assembled, the bearing will be fully seated against the shoulder on both the shaft and sideplate.

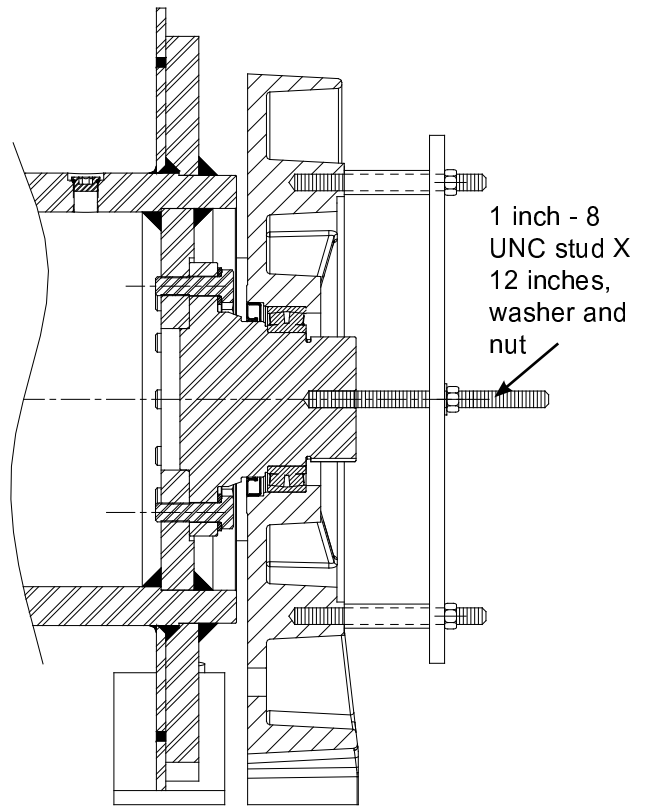

Motor End - Assembly

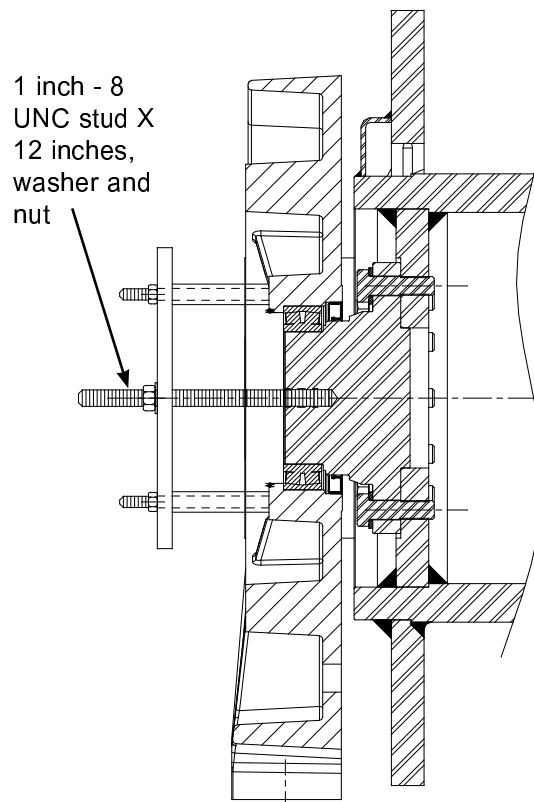

Support End - Assembly

After assembling the support end, remove the assembly tool. Install an O-Ring (item 9) onto the cover (item 2). Install the cover and O-Ring using capscrews and washers (items 3 & 4). Remove the plug/vent (item 7). Pump grease into fitting (item 5) until it fills the cavity. Replace the plug/vent. Use Ronex MP PT. # LU43720 grease or equivalent.

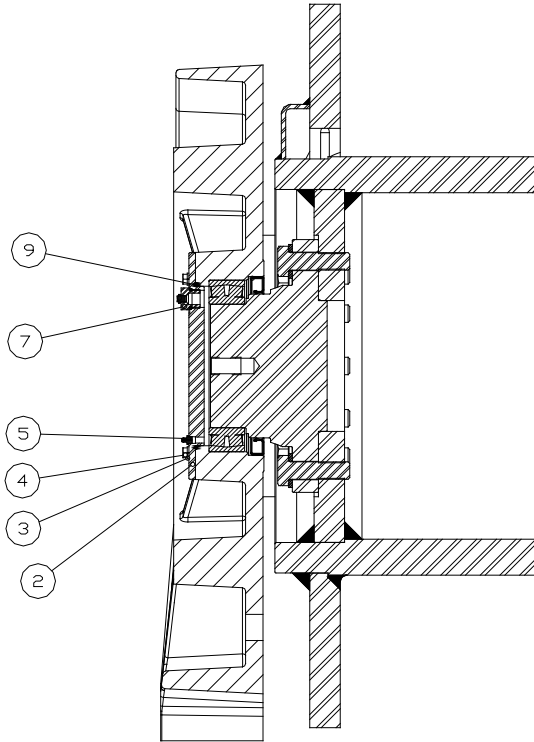

i **NOTE:** *If either drum bearing support is removed from the drum, thoroughly clean threads in the drum and capscrews. Apply Loctite 242 to all capscrews and torque to 600 lb-ft (814 N-m). Also note that there is gear oil in the drum as a rust preventative. Refer to Preventive Maintenance and Specifications for quantity.*

BRAKE SERVICE

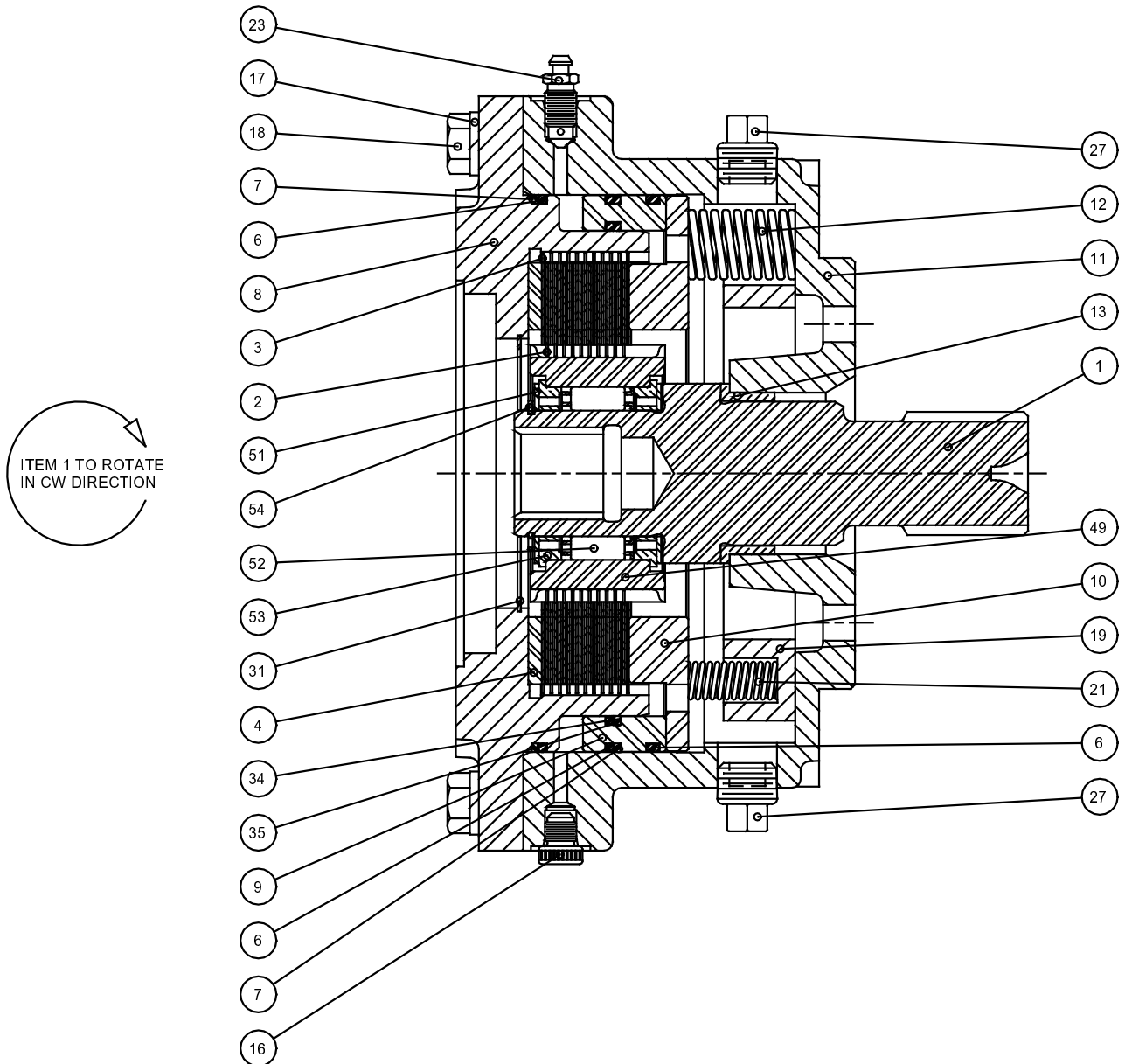

DISASSEMBLY

Remove the sprag clutch assembly, which is mounted to the gearbox input shaft. Place the brake assembly on a clean flat surface with the motor end up. Loosen capscrews (item 18) one turn at a time until the spring tension is released, then remove motor adapter (item 8). Remove and discard O-Ring and Backup ring (items 6 & 7) from the motor adapter. Remove spacer, friction and steel discs, piston and pressure plate. Remove and discard all O-Rings and backup rings from the piston. Remove all springs and spring spacer.

Thoroughly clean and inspect the brake housing (item 11). Pay particular attention to the sealing surfaces of the piston, and be sure the brake release port is clean and free of any contamination.

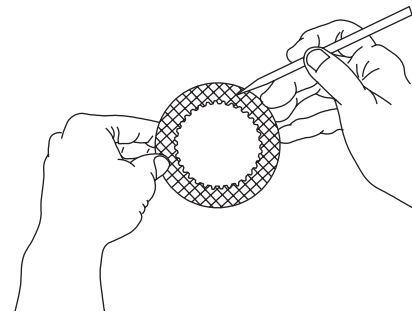

Place friction discs on a flat surface and check for distortion. Friction material should appear even across entire surface with a visible groove pattern. Replace friction disc if splines are worn to a point, disc is distorted or friction material is worn unevenly.

Place steel brake discs on a flat surface and check for distortion. Visually inspect surfaces of discs for signs of material transfer or excessive heat. Replace steel disc if splines are worn to a point, disc is distorted or heat discolored.

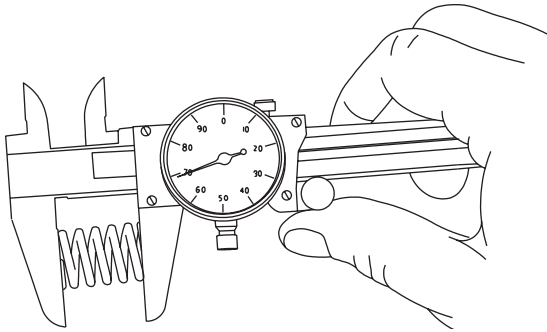

Check brake spring free length. There are two size springs in each brake assembly, 12 each large springs (item 12) and 3 each small springs (item 21). Minimum free length of the large springs is 1-15/16 inches (49.21 mm). Minimum free length of the small springs is 1-7/16 inches (36.51 mm). Check all springs for any signs of cracking or failure. If a brake spring must be replaced for any reason, then ALL brake springs must be replaced.

CAUTION

Failure to replace brake springs as a set may result in uneven brake application pressure, erratic brake operation and repeated brake spring failure.

Inspect the bushing between the shaft and brake housing and replace as necessary.

ASSEMBLY

Apply a light coat of oil to a new O-Ring and Backup ring and install them onto the motor support as shown. Backup rings are always placed on the low pressure side of the O-Ring. In this case the backup ring is toward the motor mounting surface.

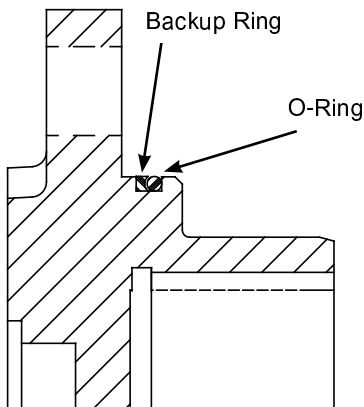

Apply a light coat of oil to new O-Rings and Backup rings for the brake piston and install them as shown below.

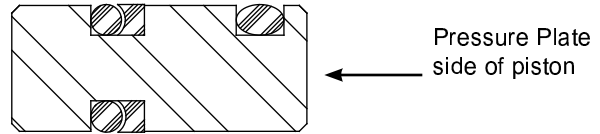

O-Rings and Backup rings should be installed at least 10 to 15 minutes before the parts are to be assembled. This time will allow them to “relax” from being stretched into their grooves and will help avoid cutting them when parts are assembled.

Place the brake housing on a clean flat work surface. Install the spring spacer into the housing. Install all 14 brake springs.

Install the pressure plate (item 10) onto the springs.

Apply a light coat of oil or petroleum jelly onto the sealing surfaces of the housing and piston and install the piston into the housing, seating it against the pressure plate.

Place the motor adapter on a clean flat work surface with the motor side down. Place the brake spacer (item 4) into the motor support. Install a steel brake disc against the spacer, followed by a friction disc. Alternately install steel and friction discs until 10 friction and 11 steel discs have been installed. A steel disc will be on the top of the stack.

NOTE: *It is good practice to pre-lubricate the discs in light motor oil prior to assembly.*

Carefully turn the motor support over, holding the discs in place through the center of the motor support. Install the motor support into the brake housing, being careful not to pinch your fingers against the pressure plate.

Install the eight capscrews and lockwashers (items 17 & 18), but do not tighten them enough to compress the springs. Install the assembled input shaft/sprag clutch through the center of the discs into the housing, turning the sprag back and forth to align the outer race splines with the brake disc splines. When all brake discs are properly aligned, evenly tighten the eight capscrews to compress the brake springs, and torque to the correct value.

SPRAG CLUTCH SERVICE

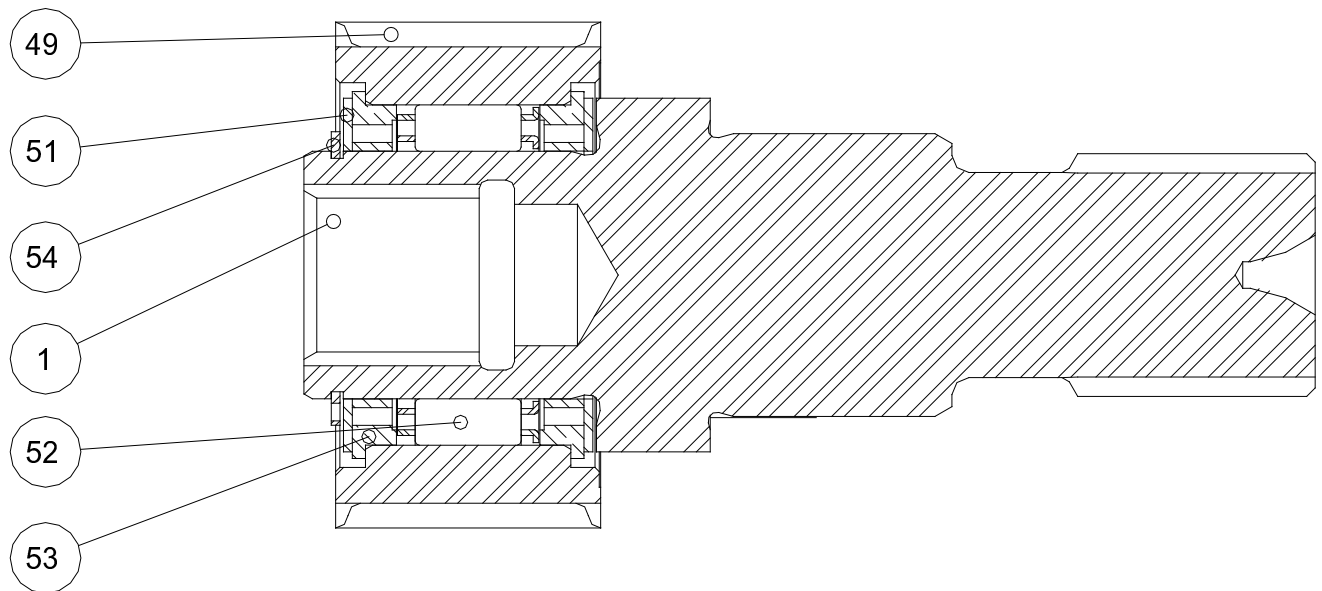

Before disassembling the clutch, determine which direction the outer race (item 49) rotates freely when the inner race/shaft is held firm.

Remove the retaining ring (item 54) and sprag bushing retainer (item 51). Pull the outer race (item 49) off of the inner race/shaft (item 1).

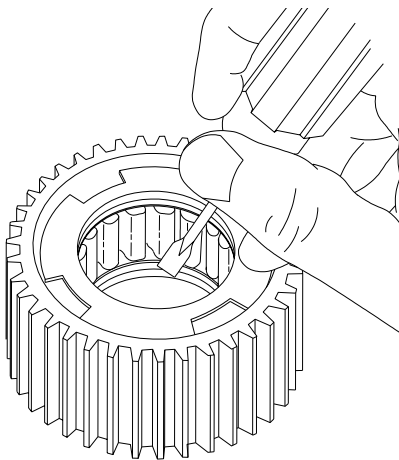

Using a screwdriver and mallet, remove the sprag bushing (item 53) from one end of the outer race. There are four special cutouts in the bushing for this purpose. Be careful not to damage the inside surface of the bushing. If the inside surface of a bushing is damaged or shows wear, replace the bushing.

Slide the sprag clutch out and inspect it very carefully for abnormal wear, cracks, pitting, corrosion or damage to the cage. Check the small clips for breakage or bright spots; the signs of excessive wear. Inspect the sprag bushing remaining in the outer race for wear or damage. If it does not need to be replaced, there is no need to remove it.

Thoroughly clean and inspect all parts before re-assembling the clutch.

⚠ WARNING ⚠

The polished surfaces of the races and sprag cams must be perfectly smooth to insure positive engagement of the clutch. The slightest defect may reduce brake clutch effectiveness, which may lead to loss of load control and result in property damage, injury or death. It is generally recommended to replace the entire brake clutch assembly if any component is defective.

Install the sprag clutch into the bore of the outer race, making sure it is installed in the same direction as removed.

Press the sprag bushing (item 53) into the outer race.

Install the outer race and sprag onto the inner race/shaft. The outer race will have to rotate in the free-wheeling direction to start it onto the inner race. Verify that the outer race rotates freely in the same direction as it did before disassembly.

Install the sprag bushing retainer (item 51) and retaining ring (item 54).

GEARBOX SERVICE

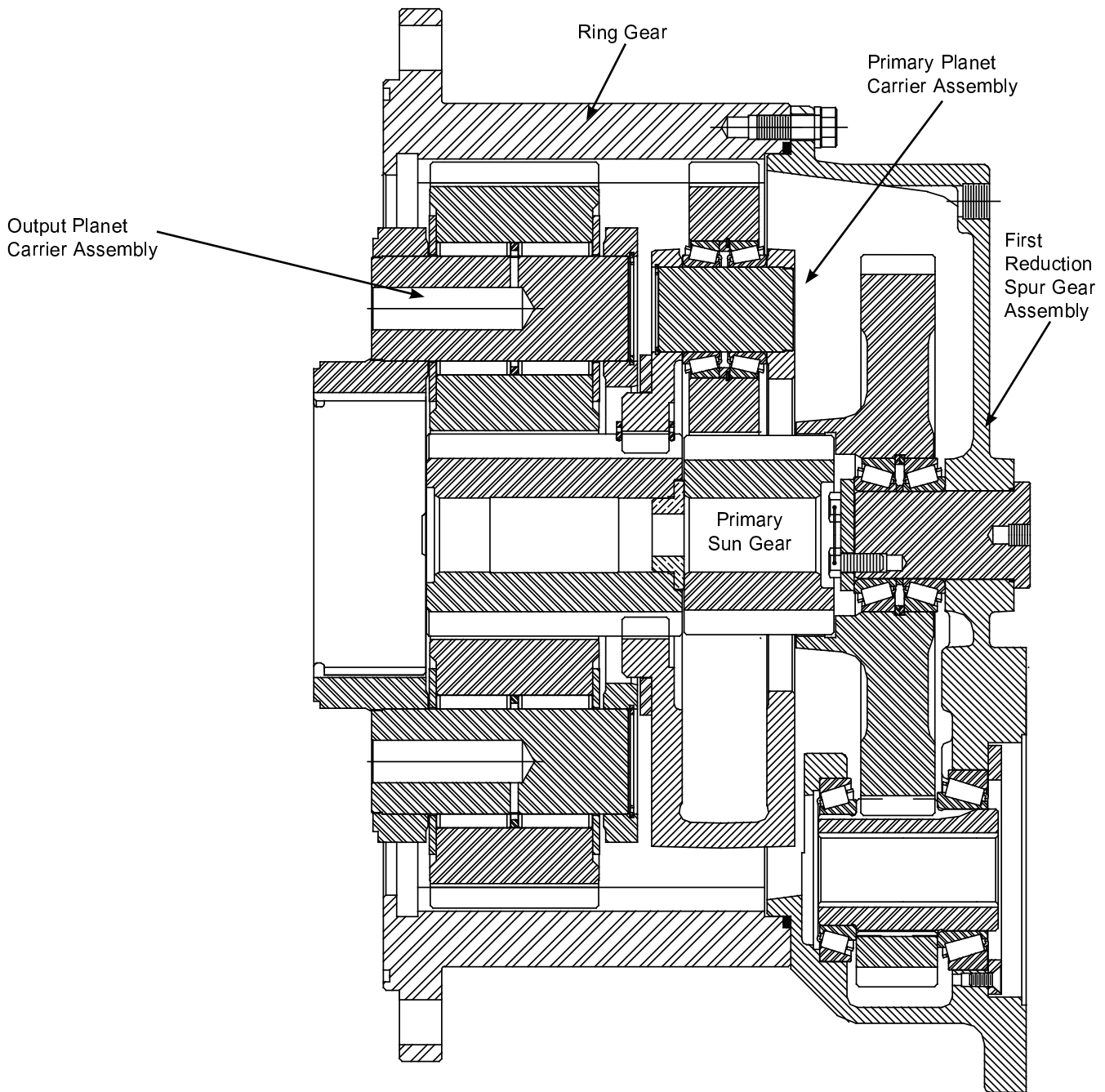

DISASSEMBLY

To disassemble the gearbox, the first reduction spur gear assembly must be separated from the ring gear. Block the assembly so it is resting on the face of the ring gear with the output planet carrier facing down, but not resting on the planet carrier. Remove all capscrews and lock-washers holding the cover to the ring gear and lift off the first reduction spur gear assembly.

Lift out the primary sun gear, the primary planet carrier assembly, thrust washer, and output planet carrier assembly.

OUTPUT PLANET CARRIER SERVICE

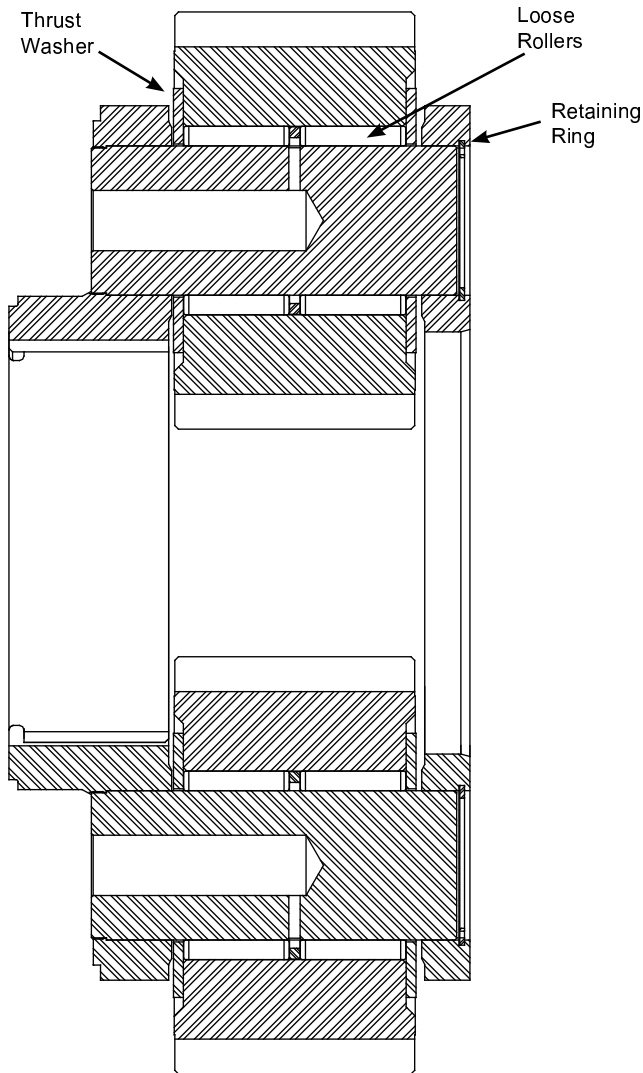

Assembly

Apply a liberal coat of oil soluble grease to a thrust washer and place it in the recess on a planet gear. Place the planet gear on a clean work surface with the thrust washer down. Apply a liberal coat of oil soluble grease to the bore of the gear. Stack a row of loose roller bearings into the planet gear, using the grease to hold them in position. There are 27 rollers in each row. Install a bearing spacer. Stack a second row of loose roller bearings on top of the bearing spacer. Place a second thrust washer on the planet gear. Carefully slide the planet gear and bearings into the carrier. Install a planet gear shaft into the carrier and through the planet gear bearings. The shaft may have to be driven in slightly to clear the retaining ring groove in the carrier. Install the retaining ring into the carrier.

Repeat this procedure for each of the planet gears.

Disassembly

Before beginning, it is recommended that you mark each gear, pin and carrier bore so that each gear and pin is re-assembled into the same bore that it was removed from.

Remove the retaining ring holding the planet gear shaft in the carrier. Remove the planet gear shaft from the carrier.

Slide the planet gear, thrust washers and bearings out of the carrier. Remove the thrust washers, loose roller bearings and bearing spacer from the gear. Repeat this procedure for each of the planet gears.

Thoroughly clean and inspect all parts for signs of abnormal wear or damage and replace as necessary. Pay particular attention to bearings and bearing surfaces. The bearing rollers should not exhibit any irregularities. If the rollers show any sign of spalling, corrosion, discoloration, material displacement or abnormal wear, the bearings should be replaced.

PRIMARY PLANET CARRIER SERVICE

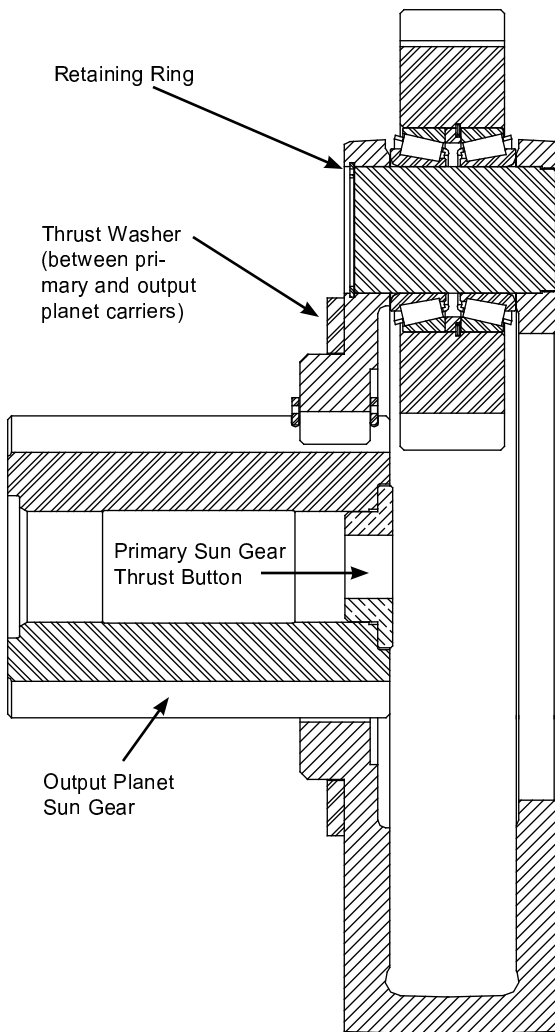

Disassembly

Remove and inspect the thrust washer that is between the primary and output planet carriers. If it exhibits any signs of excessive wear or damage, replace it.

Inspect the primary sun gear thrust button and replace it if there are signs of excessive wear or damage.

The output planet sun gear is attached to the primary planet carrier with two retaining rings. It is not necessary to remove the sun gear unless it needs to be replaced.

Before removing the planet gears, it is recommended that you mark each gear, pin and carrier bore so that each gear and pin is re-assembled into the same bore that it was removed from.

Remove the retaining ring holding the planet gear shaft in the carrier. Remove the planet gear shaft from the carrier.

Slide the planet gear and bearings out of the carrier. Remove the tapered roller bearings, bearing spacer and retaining ring from the gear. Repeat this procedure for each of the planet gears.

Thoroughly clean and inspect all parts for signs of abnormal wear or damage and replace as necessary.

Pay particular attention to bearings and bearing surfaces. The bearing rollers should not exhibit any irregularities. If the rollers show any sign of spalling, corrosion, discoloration, material displacement or abnormal wear, the bearing should be replaced. Likewise, the cage should be inspected for unusual wear or deformation, particularly the cage bars. If there is any damage that will impair the cage's ability to separate, retain and guide the rollers properly, the bearing should be replaced.

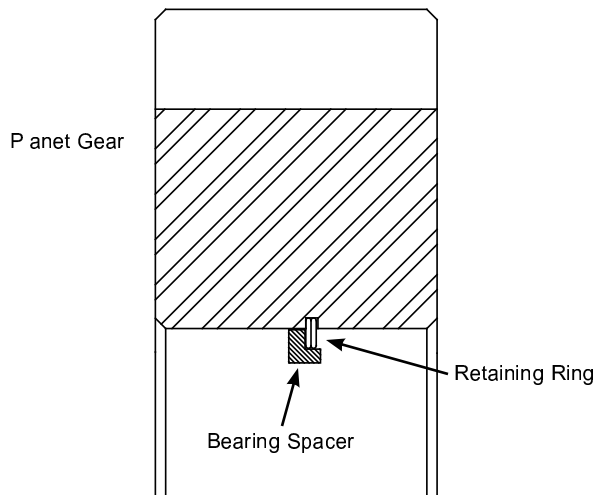

Assembly

Install retaining ring into the groove in the bore of a planet gear.

NOTE: *The groove is slightly off center in the bore of the gear. This is to allow the bearing spacer to be centered in the bore when properly installed. The distance from the outside edge of the gear to the spacer must be the same on both sides.*

Install both bearing cups into the gear, seating them firmly against the spacer. Install both bearing cones into the gear, and carefully slide the gear and bearings into the planet carrier. Install a planet gear shaft into the carrier and through the planet gear bearings. The shaft may have to be driven in slightly to clear the retaining ring groove in the carrier. Install the retaining ring into the carrier.

Repeat this procedure for each of the planet gears.

FIRST REDUCTION SPUR GEAR ASSEMBLY SERVICE

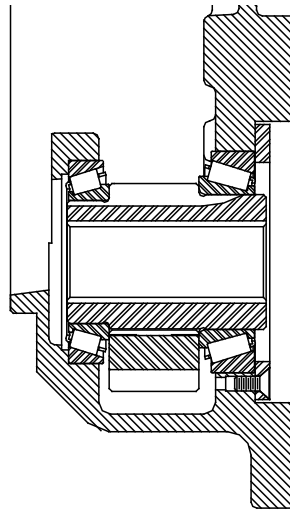
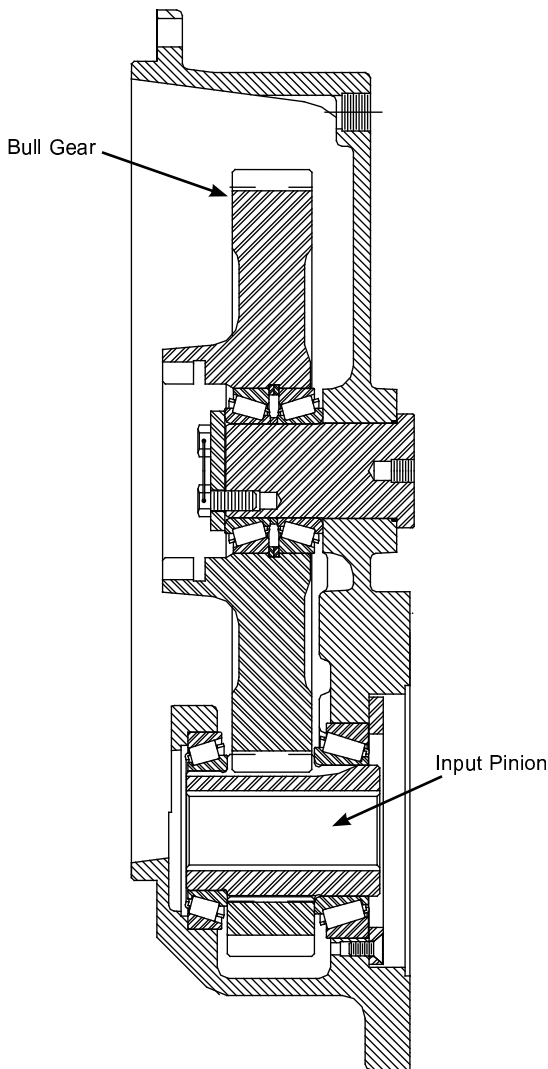

Remove the flat head capscrews holding the bearing retainer plate to the housing. Support the housing on the brake mounting surface and press out the pinion gear and bearings. Thoroughly clean and inspect the gear and bearings and replace as required.

Disassembly

Remove the safety wire on the three capscrews holding the bull gear bearing retainer in place. Remove the capscrews and retaining plate. Support the housing and press out the bull gear shaft. Remove and discard the O-Ring from the shaft. Lift the bull gear and its bearings out of the housing.

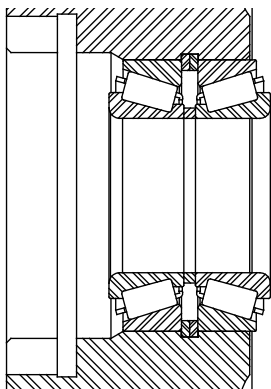

Remove the bearing cones and thoroughly clean and inspect them. The bearings and spacers in the bull gear are a matched set and must be replaced as a complete set. DO NOT replace individually.

WINCH ASSEMBLY

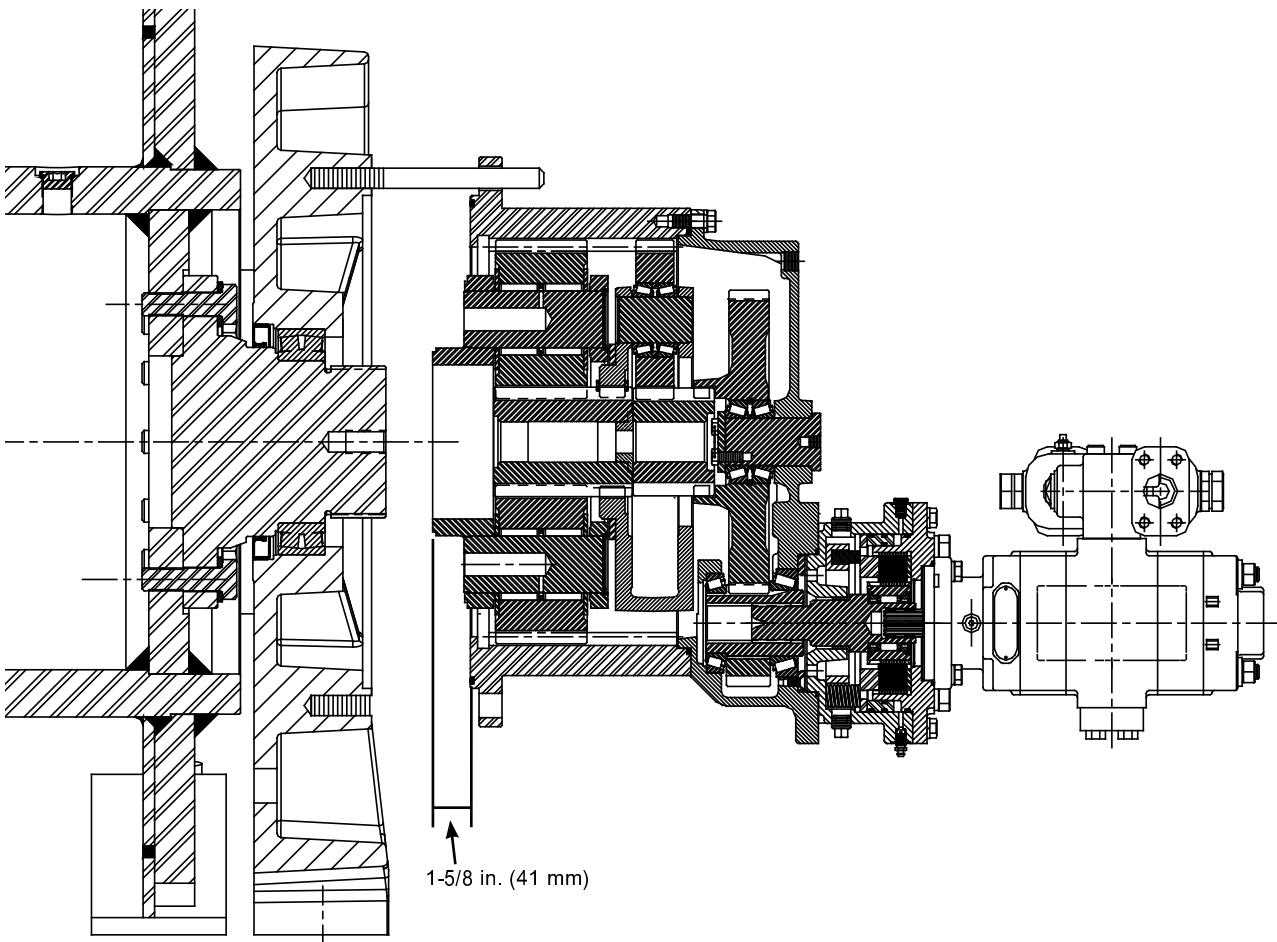

Assemble sideplates and drum as shown on pages 11 & 12.

If the gearbox was not disassembled, install the three rods used to remove the gearbox into the top three holes in the side plate. Apply a liberal coating of grease or petroleum jelly to a new O-Ring and install it into the groove on the face of the ring gear.

CAUTION

Check the dimension shown above. If the two planet carrier assemblies have moved apart from each other, the thrust washer between them may have moved out of position. If the output planet carrier assembly cannot be moved into the ring gear as shown, the gearbox will have to be partially disassembled to re-position the thrust washer. If the thrust washer is out of position, the ring gear will not seat against the side plate

Slide the gearbox onto the three rods and engage the splines in the output carrier with those on the drum drive shaft. It may be necessary to slightly rotate the drum to align the splines. Install the capscrews and lockwashers fastening the ring gear to the sideplate. Evenly tighten all capscrews until the ring gear is pulled against the sideplate. Remove the three rods and replace with

capscrews and lockwashers. Torque all capscrews to 600 lb-ft (814 N-m).

If the gearbox is disassembled, the recommended procedure is to fasten the empty ring gear to the sideplate. Be sure to install a new O-Ring on the face of the ring gear and torque all capscrews to the value shown above. Slide the output planet carrier assembly into the ring gear and engage the splines in the output carrier with those on the drum drive shaft.

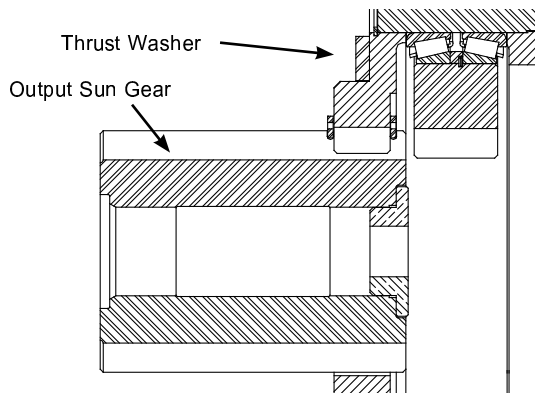

Apply a liberal coating of oil soluble grease to the thrust washer and position it on the primary planet carrier as shown. Slide the planet carrier assembly into the ring gear, engaging the output sun gear with the planet gears in the output planet carrier assembly.

Install the primary sun gear into the center of the primary planet carrier assembly. Install a new O-Ring onto the spur gear assembly cover. Install the spur gear assembly onto the ring gear. It may be necessary to rotate the input pinion slightly to align the bull gear with the input sun gear. Be sure the input to the gearbox is properly oriented and install all capscrews and lockwashers fastening the cover to the ring gear. Torque all capscrews to the correct value shown in the recommended fastener torque chart.

Install the brake/s and motor/s onto the gearbox cover. Connect all hoses and fittings that were previously removed.

**HOSES AND FITTINGS
(DUAL MOTORS, SINGLE C.B. VALVE PER MOTOR, WITH RATCHET AND PAWL)**

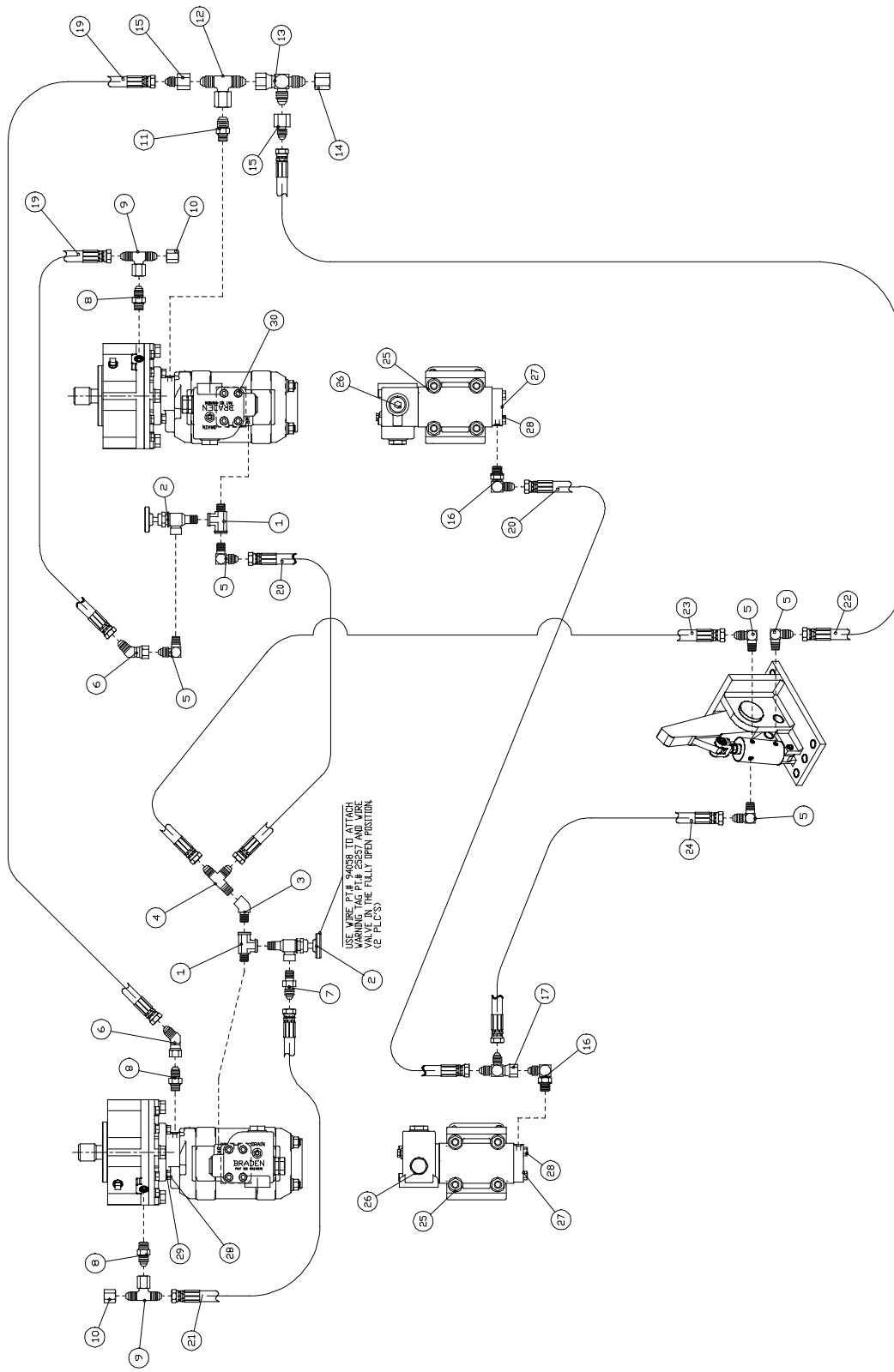

HOSES AND FITTINGS (DUAL MOTORS, SINGLE C.B. VALVE PER MOTOR)

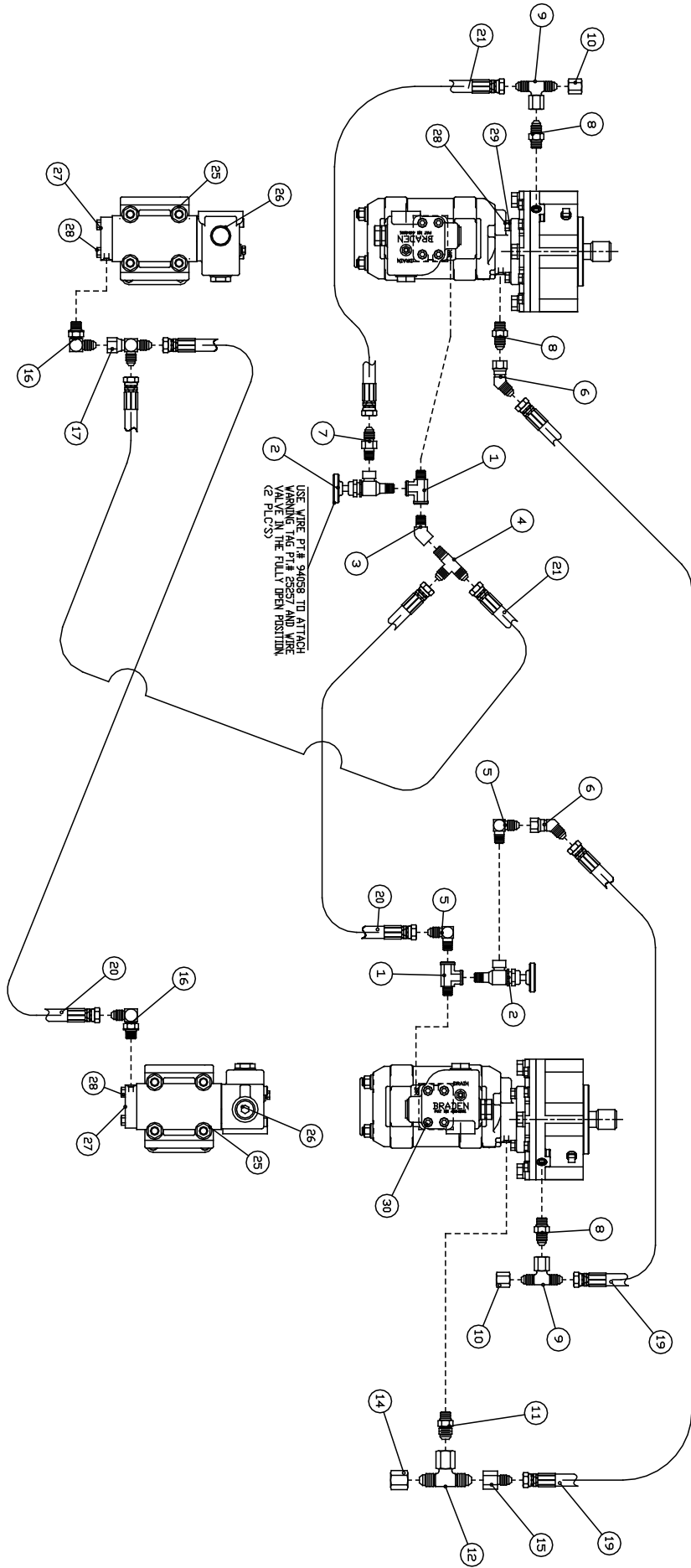

HOSES AND FITTINGS (DUAL TANDEM MOTORS, TWO C.B. VALVES PER MOTOR, WITH RATCHET AND PAWL)

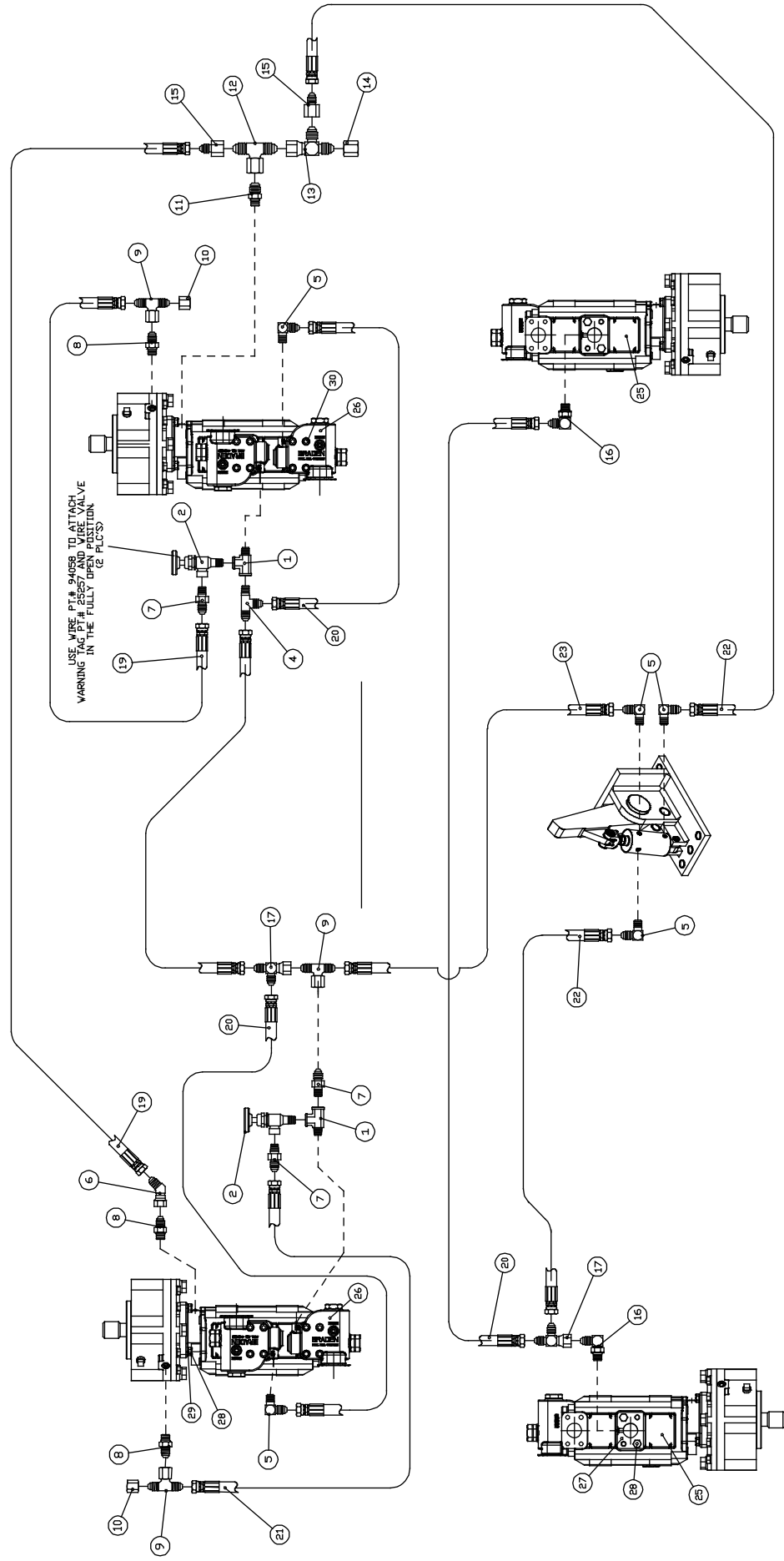

**HOSES AND FITTINGS
(DUAL TANDEM MOTORS, TWO C.B. VALVES PER MOTOR)**

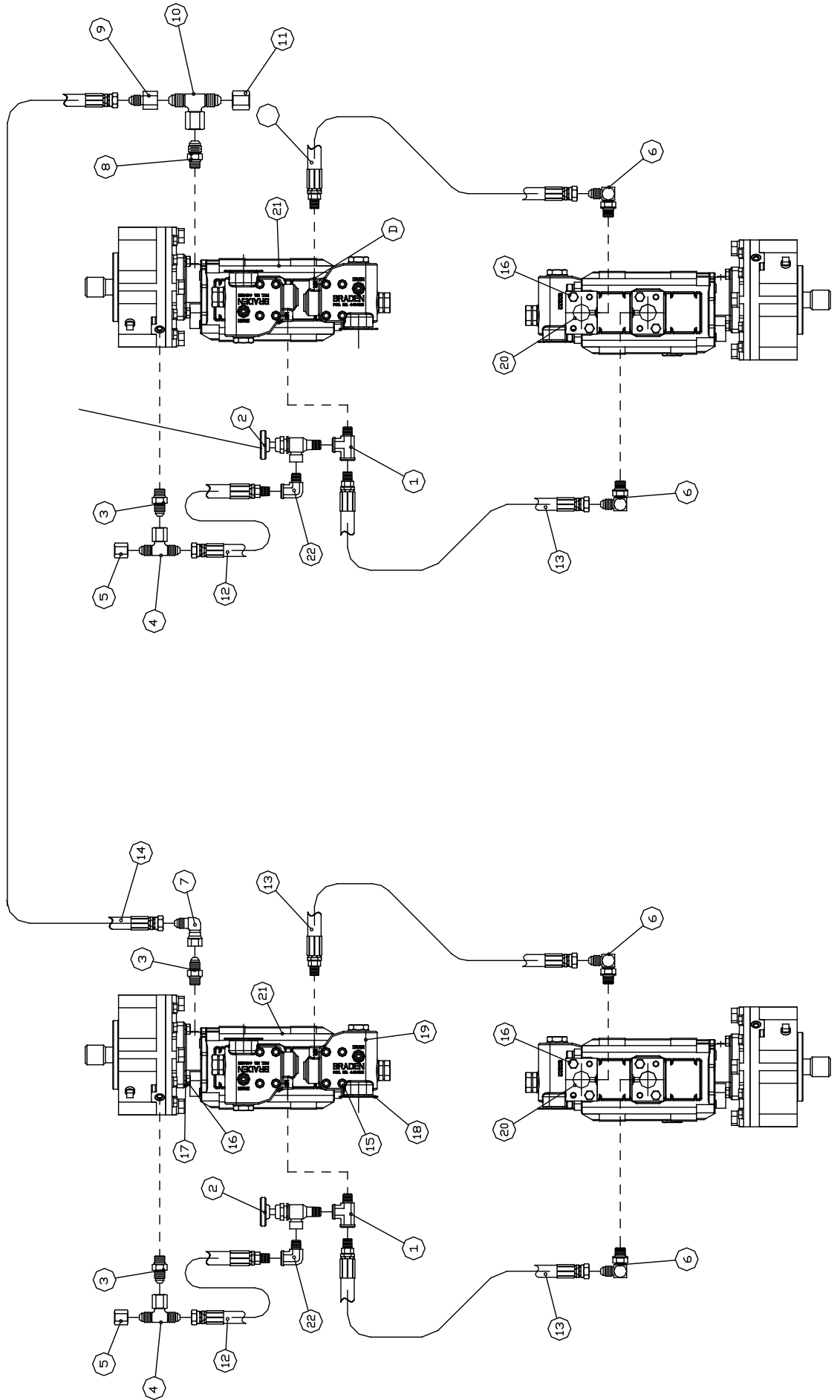

**HOSES AND FITTINGS
(SINGLE MOTOR, TWO C.B. VALVES)**

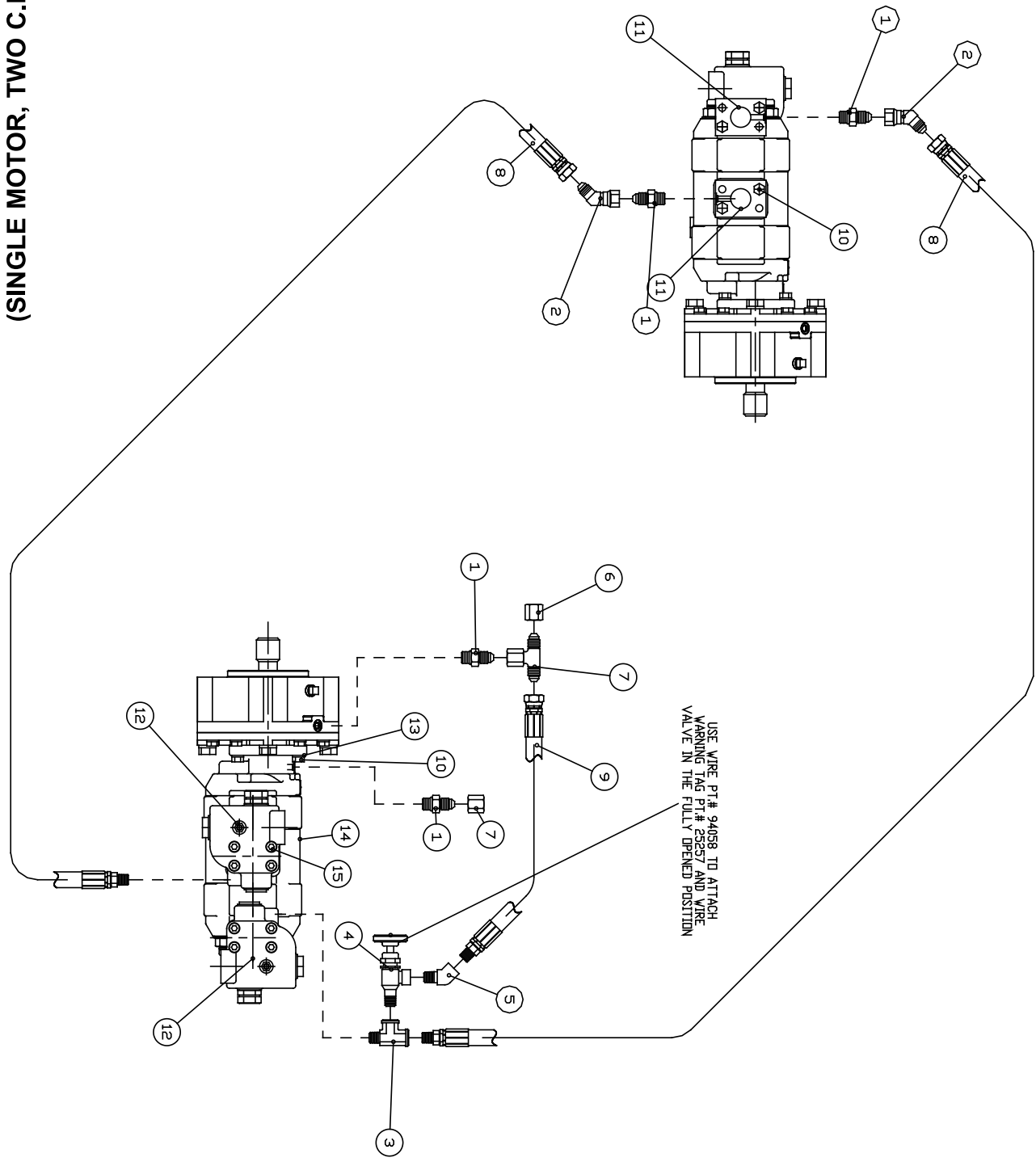

TYPICAL CH640 EXPLODED VIEW

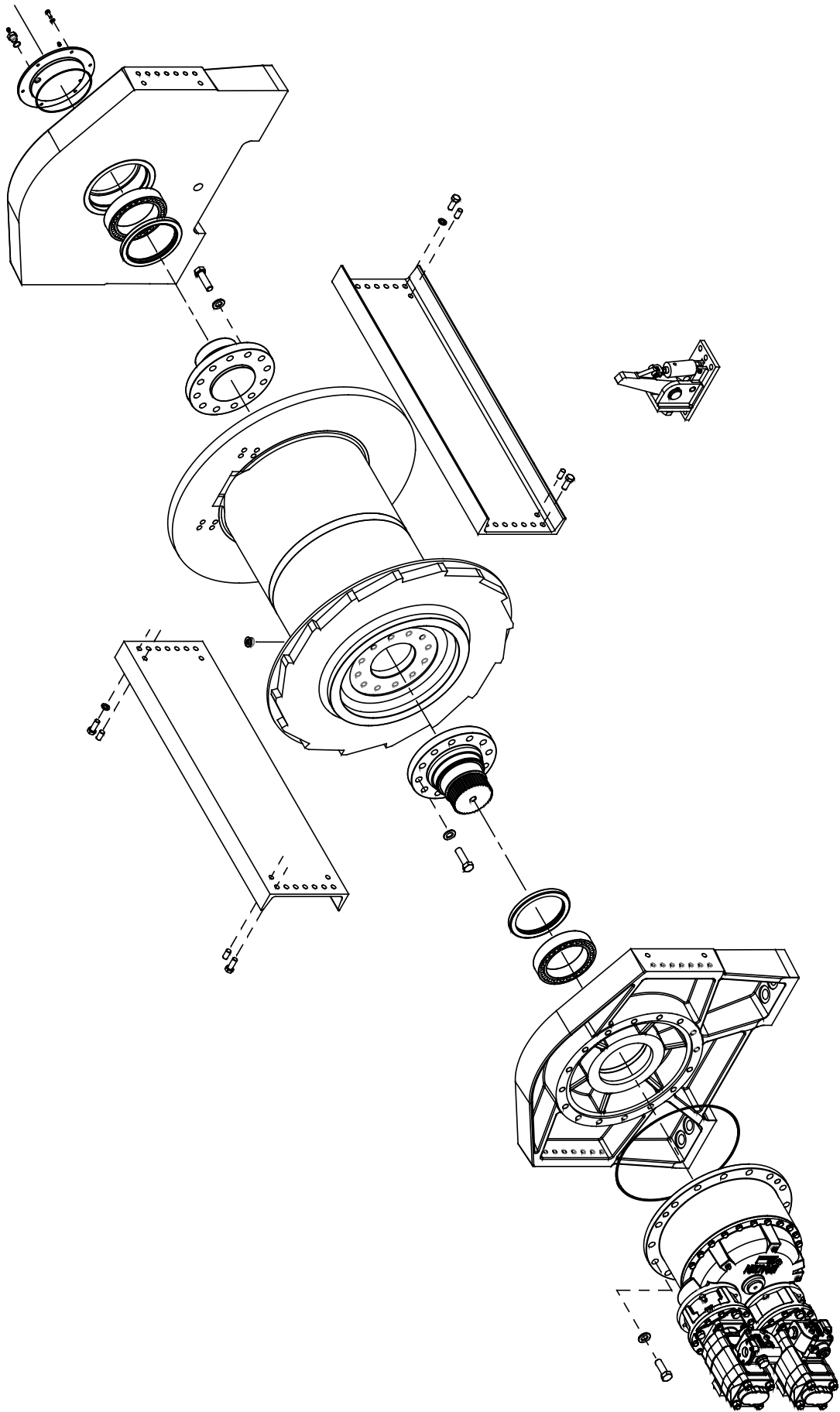

THIS PAGE INTENTIONALLY LEFT BLANK

METRIC CONVERSION TABLE

English to Metric			Metric to English		
LINEAR					
inches (in.)	X 25.4	= millimeters (mm)	millimeters (mm)	X 0.3937	= inches (in.)
feet (ft.)	X 0.3048	= meters (m)	meters (m)	X 3.281	= feet (ft.)
miles (mi.)	X 1.6093	= kilometers (km)	kilometers (km)	X 0.6214	= miles (mi.)
AREA					
inches ² (sq.in.)	X 645.15	= millimeters ² (mm ²)	millimeters ² (mm ²)	X 0.000155	= inches ² (sq.in.)
feet ² (sq.ft.)	X 0.0929	= meters ² (m ²)	meters ² (m ²)	X 10.764	= feet ² (sq.ft.)
VOLUME					
inches ³ (cu.in.)	X 0.01639	= liters (l)	liters (l)	X 61.024	= inches ³ (cu.in.)
quarts (qts.)	X 0.94635	= liters (l)	liters (l)	X 1.0567	= quarts (qts.)
gallons (gal.)	X 3.7854	= liters (l)	liters (l)	X 0.2642	= gallon (gal.)
inches ³ (cu.in.)	X 16.39	= centimeters ³ (cc)	centimeters ³ (cc)	X 0.06102	= inches ³ (cu.in.)
feet ³ (cu.ft.)	X 28.317	= liters (l)	liters (l)	X 0.03531	= feet ³ (cu.ft.)
feet ³ (cu.ft.)	X 0.02832	= meters ³ (m ³)	meters ³ (m ³)	X 35.315	= feet ³ (cu.ft.)
fluid ounce (fl.oz.)	X 29.57	= milliliters (ml)	milliliters (ml)	X 0.03381	= fluid ounce (fl.oz.)
MASS					
ounces (oz.)	X 28.35	= grams (g)	grams (g)	X 0.03527	= ounces (oz.)
pounds (lbs.)	X 0.4536	= kilograms (kg)	kilograms (kg)	X 2.2046	= pounds (lbs.)
tons (2000 lbs.)	X 907.18	= kilograms (kg)	kilograms (kg)	X 0.001102	= tons (2000 lbs.)
tons (2000 lbs.)	X 0.90718	= metric tons (t)	metric tons (t)	X 1.1023	= tons (2000 lbs.)
tons (long) (2240 lbs.)	X 1013.05	= kilograms (kg)	kilograms (kg)	X 0.000984	= tons (long) (2240 lbs.)
PRESSURE					
inches Hg (60°F)	X 3600	= kilopascals (kPa)	kilopascals (kPa)	X 0.2961	= inches Hg (60°F)
pounds/sq.in. (PSI)	X 6.895	= kilopascals (kPa)	kilopascals (kPa)	X 0.145	= pounds/sq.in. (PSI)
pounds/sq.in. (PSI)	X 0.0703	= kilograms/sq.cm. (kg/cm ²)	kilograms/sq.cm. (kg/cm ²)	X 14.22	= pounds/sq.in. (PSI)
pounds/sq.in. (PSI)	X 0.069	= bars	bars	X 14.5	= pounds/sq.in. (PSI)
inches H ₂ O (60°F)	X 0.2488	= kilopascals (kPa)	kilopascals (kPa)	X 4.0193	= inches H ₂ O (60°F)
bars	X 100	= kilopascals (kPa)	kilopascals (kPa)	X 0.01	= bars
POWER					
horsepower (hp)	X 0.746	= kilowatts (kW)	kilowatts (kW)	X 1.34	= horsepower (hp)
ft.-lbs./min.	X 0.0226	= watts (W)	watts (W)	X 44.25	= ft.-lbs./min.
TORQUE					
pound-inches (in.-lbs.)	X 0.11298	= newton-meters (N-m)	newton-meters (N-m)	X 8.851	= pound-inches (in.-lbs.)
pound-feet (ft.-lbs.)	X 1.3558	= newton-meters (N-m)	newton-meters (N-m)	X 0.7376	= pound-feet (ft.-lbs.)
pound-feet (ft.-lbs.)	X .1383	= kilograms/meter (kg-m)	kilogram/meter (kg-m)	X 7.233	= pound-feet (ft.-lbs.)
VELOCITY					
miles/hour (m/h)	X 0.11298	= kilometers/hour (km/hr)	kilometers/hour (km/hr)	X 0.6214	= miles/hour (m/h)
feet/second (ft./sec.)	X 0.3048	= meter/second (m/s)	meters/second (m/s)	X 3.281	= feet/second (ft./sec.)
feet/minute (ft./min.)	X 0.3048	= meter/minute (m/min)	meters/minute (m/min)	X 3.281	= feet/minute (ft./min.)
TEMPERATURE					
°Celsius = 0.556 (°F - 32)			°Fahrenheit = (1.8°C) + 32		
COMMON METRIC PREFIXES					
mega	(M)	= 1,000,000 or 10 ⁶	deci	(d)	= 0.1 or 10 ⁻¹
kilo	(k)	= 1,000 or 10 ³	centi	(c)	= 0.01 or 10 ⁻²
hecto	(h)	= 100 or 10 ²	milli	(m)	= 0.001 or 10 ⁻³
deka	(da)	= 10 or 10 ¹	micro	(μ)	= 0.000.001 or 10 ⁻⁶

